



Certified to NSF/ANSI/CAN 61



Deep Well
Submersible
Electric Motor

6SME 6"
8SME 8"
10SME 10"

2-Pole
50/60 Hz



ALL
SME
MOTORS
ARE
OPTIONALLY
AVAILABLE
IN
316L SS



Sr #	Description	Page No.
1	6SME 60 Hz 230V- Single Phase Motor Spec & Data	4 - 5
2	6SME- Motor Picture and Summary	6
3	6SME- Cross Sectional View with Specifications	7
4	6SME- Key Features	8
5	6SME- Specifications	8
6	6SME- Technical Specifications	8
7	6SME 60 Hz 208V/230V- Electrical Data	9
8	6SME 60 Hz 208V/230V- Size & Dimensions Motor Lead	9
9	6SME 60 Hz 380V/460V- Electrical Data	10
10	6SME 60 Hz 380V/460V- Size & Dimensions Motor Lead	10
11	6SME 60 Hz 208V- Motor Performance Curves	11 - 18
12	6SME 60 Hz 230V- Motor Performance Curves	19 - 26
13	6SME 60 Hz 380V- Motor Performance Curves	27 - 35
14	6SME 60 Hz 460V- Motor Performance Curves	36 - 46
15	6SME 50 Hz- Electrical Data	47
16	6SME 50 Hz- Size & Dimensions Motor Lead	47
17	6SME 50 Hz- Motor Performance Curves	48 - 58
18	6SME- Motor Dimensions & Weights	59
19	6SME- Exploded View	60
20	6SME- Cross Sectional View	60
21	6SME- Parts List with Material & Quantity	61
22	8SME- Motor Picture and Summary	62
23	8SME- Cross Sectional View with Specifications	63
24	8SME- Key Features	64
25	8SME- Specifications	64
26	8SME- Technical Specifications	64
27	8SME 60 Hz- Electrical Data	65
28	8SME 60 Hz- Size & Dimensions Motor Lead	65
29	8SME 60 Hz 230V- Motor Performance Curves	66 - 68
30	8SME 60 Hz 460V- Motor Performance Curves	69 - 77
31	8SME 50 Hz- Electrical Data	78
32	8SME 50 Hz- Size & Dimensions Motor Lead	78
33	8SME 50 Hz 380V- Motor Performance Curves	79 - 87
34	8SME- Motor Dimensions & Weights	88
35	8SME- Exploded View	89
36	8SME- Cross Sectional View	89
37	8SME- Parts List with Material & Quantity	90
38	10SME- Motor Picture and Summary	91
39	10SME- Key Features	92
40	10SME- Specifications	92
41	10SME- Technical Specifications	92
42	10SME 60 Hz- Electrical Data	93
43	10SME 50 Hz- Electrical Data	93
44	10SME- Size & Dimensions Motor Lead	93
45	10SME 60 Hz 460V- Motor Performance Curves	94 - 101
46	10SME 50 Hz 380V- Motor Performance Curves	102 - 108
47	10SME- Motor Dimensions & Weights	109
48	10SME- Exploded View	110
49	10SME- Cross Sectional View	110
50	10SME- Parts List with Material & Quantity	111
51	SME Motors Thrust Bearings Types	112 - 113
52	SME Motor PT100 Sensor Features	114
53	SME Motor PT100 Sensor Cables	114
54	SME Motor Cable Selection Charts	115 - 121

Also Available in Complete 316L SS

Key Features

The 6SME 6" single-phase submersible motors are designed to meet market demands, emphasizing energy efficiency, reliability, and long service life. These water-filled motors feature a rewindable asynchronous single-phase stator and a squirrel cage rotor, ensuring high quality and trouble-free operation.

- Wet Stator Design
- High Grade Material
- High Thermal Capacity
- Water Cooled
- NSF and ISO Certified
- Domestic, Commercial, Industrial & Agriculture Application
- Easy Maintenance
- Long Service Life
- High Efficiency
- Re-windable
- Eco Friendly

Specifications

Winding: Uses electrolytic solid copper wire with high-temperature BOPP+BOPET insulation, allowing for cooler operation and higher horsepower in standard frames.

Stator: Features an extended stack length and M800 low-loss magnetic sheet to reduce heat and improve efficiency.

Rotor: Designed with increased length and M800 magnetic sheet; includes high-grade copper bars for enhanced performance.

Spline Shaft: Made from AISI 431 stainless steel, induction hardened, and ground to meet international 6" NEMA standards for durability in harsh environments.

Shaft Bearings: Dual, water-lubricated, high-grade carbon guide bearings provide stable performance in sandy wells and minimize vibration.

Thrust Bearings: Kingsbury-type thrust bearings with carbon discs and hardened stainless steel shoes support axial loads up to 6000 lbs.

Seal Configuration: Triple-seal system includes two NBR lip seals and one Tungsten Carbide seal for superior sand protection..

Pressure Equalizing System: An NBR bellow compensates for internal fluid expansion and external pressure at depth.

Bearing Housings: Made of durable cast iron with stainless steel jackets for added strength and corrosion resistance.

Filler Fluid: A water and NSF-compliant Mono Propylene Glycol/Glycerin mix ensures optimal cooling, lubrication, and corrosion protection.

Note: All specifications are subject to change without any prior notice.



SUBMERSIBLE
ELECTRIC MOTOR
6SME
SINGLE PHASE

6" 60 HZ SERIES

Single Phase

Electrical DATA

Electrical Data - Single Phase - 230V - 60 Hz - 2 Poles											
Motor Type	Motor Size		Thrust Load (lbs)	RPM	Full Load Current (Amps)	S.F Load Current (Amps)	Starting Current (Amps)	KVA Code	Cos. ϕ at Full Load	Efficiency at Full Load (%)	Service Factor
	HP	kW									
6SME 050-SP	5	3.7	6000	3500	24.8	28.5	145	N	0.94	74	1.15
6SME 075-SP	7.5	5.5	6000	3500	34.7	39.9	200	M	0.94	75	1.15
6SME 100-SP	10	7.5	6000	3500	44.9	51.6	253	M	0.95	76	1.15
6SME 150-SP	15	11	6000	3500	62.6	72.0	346	L	0.96	78	1.15

Motor Type	Motor Size		Motor Volts	Capacitor Size, Combination and Volts	
	HP	kW		Start Capacitor	Run Capacitor
6SME 050-SP	5	3.7	230	450 uF / 330VAC	
6SME 075-SP	7.5	5.5	230	600 uF / 330VAC	
6SME 100-SP	10	7.5	230	750 uF / 330VAC	
6SME 150-SP	15	11	230	1000 uF / 330VAC	

Technical DETAILS

Motor Dimensions and Weights							
Motor Type	Motor Size		L Motor Length (inch)	L1 Motor Length (inch)	Packing Dimension W x H x L (inch)	Weight (Lbs)	
	HP	kW				Without Packing	With Packing
6SME 050-SP	5	3.7	34.3	31.4	10.4 x 13.8 x 37.4	141	165
6SME 075-SP	7.5	5.5	35.8	33.0	10.4 x 13.8 x 39.5	149	172
6SME 100-SP	10	7.5	37.3	34.5	10.4 x 13.8 x 40.6	160	184
6SME 150-SP	15	11	40.9	38.1	10.4 x 13.8 x 44.4	182	207

Size & Dimensions Motor Leads - DOL - Single Phase								
Sr. No.	Motor Size		Lead Size			Dimension B x H (inch)	Cable Length (Feet)	Qty (Nr.)
	HP	kW	Core	mm ²	AWG			
1	5 ~ 15	3.7 ~ 11	3	10	8	0.95 x 0.35	13	3
			1	12	6			

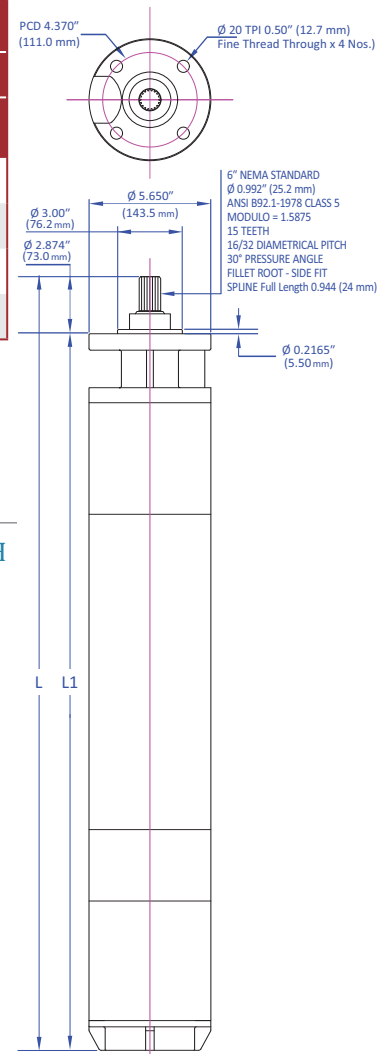

6" 60 HZ SERIES

Single Phase

Technical Specification

Degree of protection	IP68
Insulation class	Y*
Working temperature	122 °F
Voltage tolerance	+ 6% / - 10%
Mounting position	Vertical/Horizontal
Min./Max. flow rate speed	0.5-12 ft/sec
Max. immersion depth	650 feet
Max. starts per hour	20
Packing	wooden crate

* Higher insulation wire class available.

Available Horse Power

From: 5.5 HP (4 kW)

To: 75 HP (55 kW)

Available Voltages

208 Volts - 60 Hertz

230 Volts - 60 Hertz

380 Volts - 50/60 Hertz

460 Volts - 60 Hertz

Available Speed

2-Pole

Available Insulation Class

Standard: Y

Available Material of Construction

Standard: Cast Iron Ends with
NSF Certified Epoxy

Optional: Complete 316L SS



6" SERIES

DOUBLE FLANGE
6-INCH BOREHOLE
SUBMERSIBLE ELECTRIC
REWINDABLE MOTOR

6SME

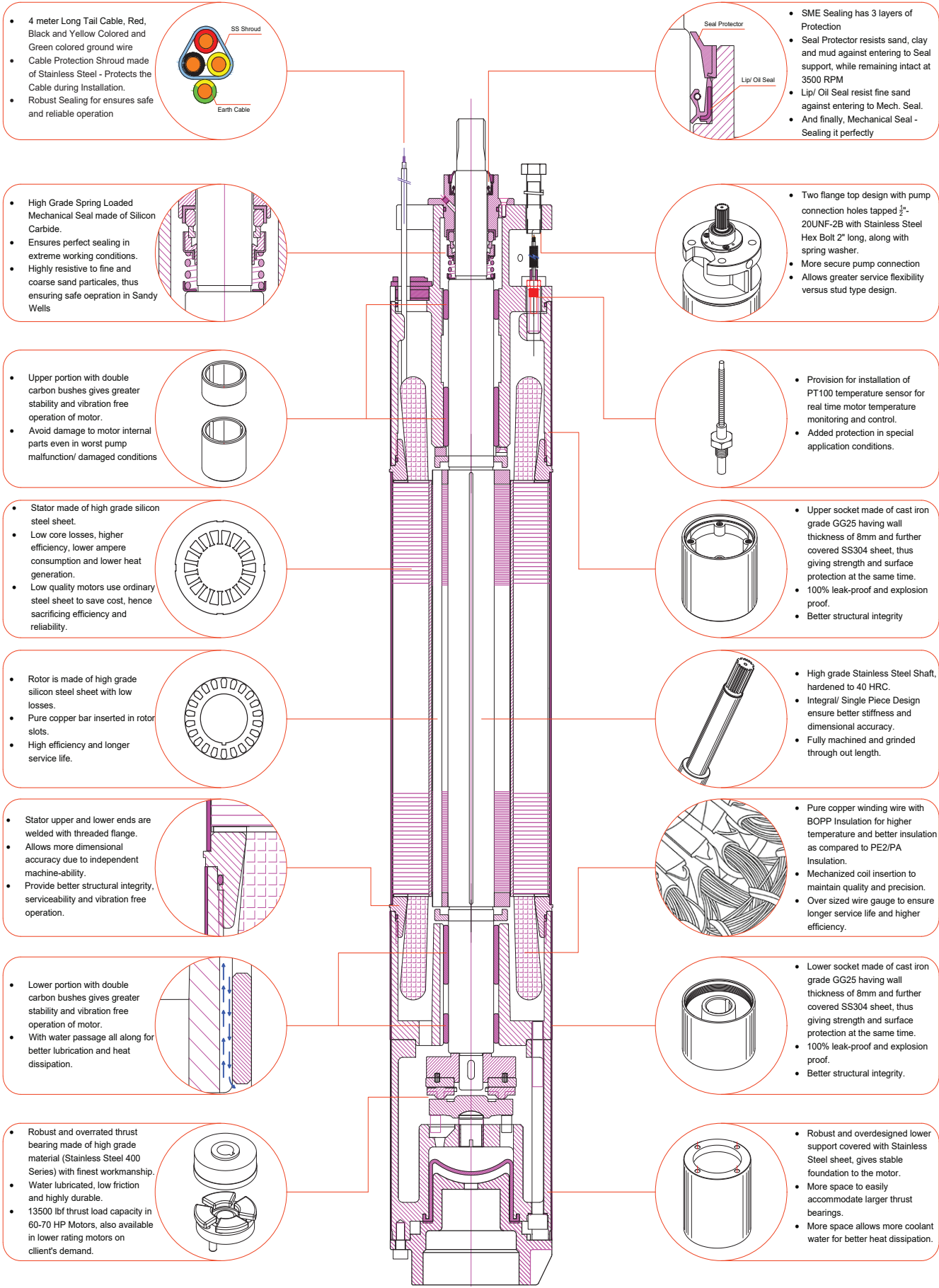

- 4 meter Long Tail Cable, Red, Black and Yellow Colored and Green colored ground wire
- Cable Protection Shroud made of Stainless Steel - Protects the Cable during Installation.
- Robust Sealing for ensures safe and reliable operation

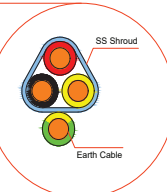

- High Grade Spring Loaded Mechanical Seal made of Silicon Carbide.
- Ensures perfect sealing in extreme working conditions.
- Highly resistive to fine and coarse sand particulates, thus ensuring safe operation in Sandy Wells

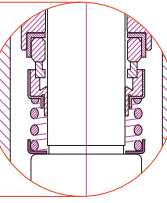

- Upper portion with double carbon bushes gives greater stability and vibration free operation of motor.
- Avoid damage to motor internal parts even in worst pump malfunction/ damaged conditions

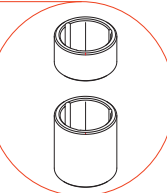

- Stator made of high grade silicon steel sheet.
- Low core losses, higher efficiency, lower ampere consumption and lower heat generation.
- Low quality motors use ordinary steel sheet to save cost, hence sacrificing efficiency and reliability.

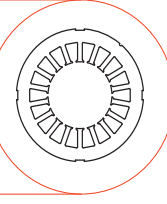

- Rotor is made of high grade silicon steel sheet with low losses.
- Pure copper bar inserted in rotor slots.
- High efficiency and longer service life.

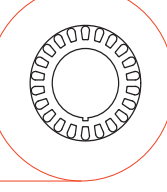

- Stator upper and lower ends are welded with threaded flange.
- Allows more dimensional accuracy due to independent machine-ability.
- Provide better structural integrity, serviceability and vibration free operation.

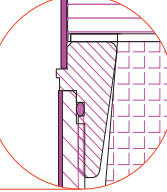

- Lower portion with double carbon bushes gives greater stability and vibration free operation of motor.
- With water passage all along for better lubrication and heat dissipation.

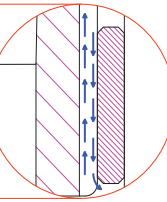

- Robust and overrated thrust bearing made of high grade material (Stainless Steel 400 Series) with finest workmanship.
- Water lubricated, low friction and highly durable.
- 13500 lbf thrust load capacity in 60-70 HP Motors, also available in lower rating motors on client's demand.

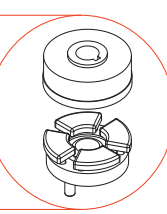

- SME Sealing has 3 layers of Protection
- Seal Protector resists sand, clay and mud against entering to Seal support, while remaining intact at 3500 RPM
- Lip/ Oil Seal resist fine sand against entering to Mech. Seal.
- And finally, Mechanical Seal - Sealing it perfectly

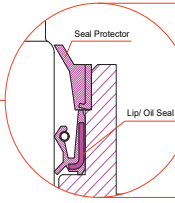

- Two flange top design with pump connection holes tapped 1/2"-20UNF-2B with Stainless Steel Hex Bolt 2" long, along with spring washer.
- More secure pump connection
- Allows greater service flexibility versus stud type design.

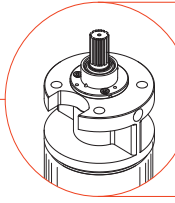

- Provision for installation of PT100 temperature sensor for real time motor temperature monitoring and control.
- Added protection in special application conditions.

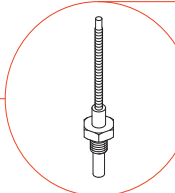

- Upper socket made of cast iron grade GG25 having wall thickness of 8mm and further covered SS304 sheet, thus giving strength and surface protection at the same time.
- 100% leak-proof and explosion proof.
- Better structural integrity

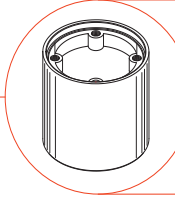

- High grade Stainless Steel Shaft, hardened to 40 HRC.
- Integral/ Single Piece Design ensure better stiffness and dimensional accuracy.
- Fully machined and grinded through out length.

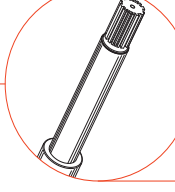

- Pure copper winding wire with BOPP Insulation for higher temperature and better insulation as compared to PE2/PA Insulation.
- Mechanized coil insertion to maintain quality and precision.
- Over sized wire gauge to ensure longer service life and higher efficiency.



- Lower socket made of cast iron grade GG25 having wall thickness of 8mm and further covered SS304 sheet, thus giving strength and surface protection at the same time.
- 100% leak-proof and explosion proof.
- Better structural integrity.

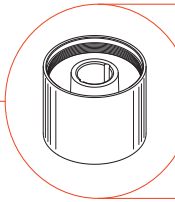

- Robust and oversized lower support covered with Stainless Steel sheet, gives stable foundation to the motor.
- More space to easily accommodate larger thrust bearings.
- More space allows more coolant water for better heat dissipation.

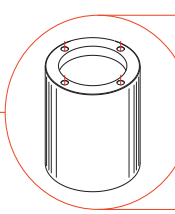

Key Features

6SME 6" submersible motors have been designed and produced according to the market's requirements. During the design and material selection phase, all efforts were made to offer an energy efficient product which stands for reliability, excellent quality, and long trouble free life.

The newly enhanced 6SME series of 6" submersible motors is specifically engineered for compatibility with VFD (Variable Frequency Drive) outputs, making it an ideal choice for solar-powered and other high-efficiency applications.

These 6" water-filled submersible motors have asynchronous three phase rewindable stator and a robust squirrel cage rotor.

- Wet Stator Design
- High Grade Material
- Easy Maintenance
- Long Service Life
- High Thermal Capacity
- High Efficiency
- Re-windable
- Eco Friendly
- NSF and ISO Certified
- Industrial, Commercial, Agriculture and Oil & Gas Application

Technical Specification

Degree of protection	IP68
Insulation class	Y*
Working temperature	122 °F
Voltage tolerance	+ 6% / - 10%
Mounting position	Vertical/Horizontal
Min./Max. flow rate speed	0.5-12 ft/sec
Max. immersion depth	650 feet
Max. starts per hour	20
Packing	wooden crate

* Higher insulation wire class available.

Specifications

Winding:

Electrolytic Solid Copper wire wrapped in BOPP+ BOPET Insulation rated for temperatures over 100°C (212 °F) that allows more copper in the current slots. This technology allows the motor to run much cooler and achieve higher than normal horsepower ratings in standard frame sizes.

Stator:

All motors include an increased Stator stack length and combined M800 low-loss electrical magnetic sheet for a cooler running motor.

Rotor:

Increased stack length with M800 low-loss electrical magnetic sheet assembled and designed with newest technology and high grade copper bars.

Spline Shaft:

AISI 400 series stainless steel induction hardened & ground to operate in severe conditions. Dimensions according to international 6" NEMA standards.

Shaft Bearings:

Dual Water lubricated guide bearings made of high grade carbon, are fixed in upper and lower brackets for optimal operation in sandy wells and pump vibration control.

Thrust Bearings:

All SME submersible motors have Kingsbury type thrust bearing. The thrust assembly consists of a high quality carbon disc with hardened stainless steel shoes to handle necessary pump thrust loads. Available with axial load capacity of 6000 Lbs (up to 40 HP), and 13849 Lbs (50 to 75 HP).

Seal Configuration:

SME offers a triple seal configuration that consists of two outer back to back lip seals in NBR with an inner Silicon Tungsten Carbide Seal for optimum protection in sandy wells.

Pressure Equalizing System:

Pressure compensation is managed by using a suitably sized NBR bellow to allow for expansion of the internal water as it heats up - or - from external pressure due to the depth of submergence.

Bearing Housings:

High resistance cast iron upper & lower bearing housing are dressed in stainless steel jackets.

Filler Fluid:

Water mixed with NSF compliant Mono Propylene Glycol / Glycerin for optimal cooling, lubrication and corrosion resistance.

Note: All specifications are subject to change without any prior notice.

Electrical DATA

Electrical Data @ 60 Hz - Three Phase - 208/230 Volt - 2 Pole

Motor Type	Motor Size		Thrust Load (lbs)	RPM	Full Load Current (Amps)	S.F Load Current (Amps)	Starting Current (Amps)	KVA Code	Cos. Φ at Full Load	Efficiency at Full Load (%)	Service Factor	
	HP	kW										
3 Phase - 208V - 60 Hz	6SME 055T	5.5	4	6000	3420	18.8	21.4	108	H	0.78	77.1	1.15
	6SME 075T	7.5	5.5	6000	3415	24.7	28.2	121	G	0.80	78.4	1.15
	6SME 100T	10	7.5	6000	3410	32.3	36.6	152	F	0.81	79.0	1.15
	6SME 150T	15	11	6000	3400	47.5	54.5	221	F	0.83	78.7	1.15
	6SME 200T	20	15	6000	3415	60.5	69.3	326	G	0.84	81.8	1.15
	6SME 250T	25	18.5	6000	3415	74.9	85.8	389	F	0.84	82.2	1.15
	6SME 300T	30	22	6000	3420	88.9	102.0	502	G	0.85	82.0	1.15
	6SME 400T	40	30	6000	3415	117.7	135.2	727	H	0.84	83.4	1.15
3 Phase - 230V - 60 Hz	6SME 055T	5.5	4	6000	3455	18.1	20.1	101	J	0.73	77.7	1.15
	6SME 075T	7.5	5.5	6000	3450	24.0	26.5	114	G	0.74	79.1	1.15
	6SME 100T	10	7.5	6000	3450	31.5	34.9	144	G	0.74	80.0	1.15
	6SME 150T	15	11	6000	3440	45.5	50.8	206	F	0.77	80.2	1.15
	6SME 200T	20	15	6000	3455	58.3	65.0	306	G	0.78	82.8	1.15
	6SME 250T	25	18.5	6000	3455	71.6	80.0	363	G	0.78	83.4	1.15
	6SME 300T	30	22	6000	3460	84.6	94.7	466	G	0.80	83.4	1.15
	6SME 400T	40	30	6000	3450	113.7	127.4	684	H	0.78	84.4	1.15

6" 60 HZ SERIES

Technical DETAILS

Size & Dimensions Motor Leads @ 60 Hz - 208/230 Volt

Sr: No.	Volt	Motor Size		Lead Size			Dimension B x H (inch)	Cable Length (Feet)	Qty (Nr.)
		HP	kW	Core	mm ²	AWG			
DOL	208V	5.5 ~ 15	4 ~ 11	3	6	10	0.75 x 0.31	13	1
				1	12	6	D = 0.27	13	1
	230V	5.5 ~ 15	4 ~ 11	3	10	8	0.95 x 0.35	13	1
				1	12	6	D = 0.27	13	1
3	208V	40	30	1	16*	6	D = 0.45	13	3
	230V	40	30	1	12	6	D = 0.27	13	1
SD	208V	5.5 ~ 30	4 ~ 22	3	6	10	0.75 x 0.31	13	2
	230V	5.5 ~ 30	4 ~ 22	1	12	6	D = 0.27	13	1

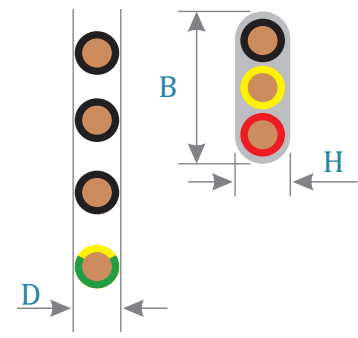

* 1 x 16 mm² as black color used for all three (3) wires.

Electrical DATA

Electrical Data @ 60 Hz - Three Phase - 380/460 Volt - 2 Pole

Motor Type	Motor Size		Thrust Load (lbs)	RPM	Full Load Current (Amps)	S.F Load Current (Amps)	Starting Current (Amps)	KVA Code	Cos. Φ at Full Load	Efficiency at Full Load (%)	Service Factor	
	HP	kW										
3 Phase - 380V - 60 Hz	6SME 055T	5.5	4	6000	3420	10.7	11.9	60	J	0.78	75.1	1.15
	6SME 075T	7.5	5.5	6000	3410	14.3	15.9	68	G	0.79	75.8	1.15
	6SME 100T	10	7.5	6000	3430	18.2	20.4	85	F	0.79	79.0	1.15
	6SME 150T	15	11	6000	3430	26.4	29.8	121	F	0.80	80.9	1.15
	6SME 200T	20	15	6000	3440	34.3	38.6	181	G	0.81	81.5	1.15
	6SME 250T	25	18.5	6000	3445	41.8	47.0	213	G	0.81	83.8	1.15
	6SME 300T	30	22	6000	3445	50.7	56.5	279	G	0.80	84.3	1.15
	6SME 400T	40	30	6000	3450	66.6	74.8	402	H	0.79	86.0	1.15
	6SME 500T	50	37	13849	3425	84.2	95.2	518	H	0.80	83.9	1.15
3 Phase - 460V - 60 Hz	6SME 055T	5.5	4	6000	3420	8.9	9.9	50	J	0.77	75.1	1.15
	6SME 075T	7.5	5.5	6000	3410	11.9	13.3	57	G	0.78	75.9	1.15
	6SME 100T	10	7.5	6000	3430	15.2	17.1	71	G	0.78	79.1	1.15
	6SME 150T	15	11	6000	3430	22.1	24.9	101	F	0.79	81.0	1.15
	6SME 200T	20	15	6000	3440	28.7	32.2	151	G	0.80	81.6	1.15
	6SME 250T	25	18.5	6000	3445	34.9	39.3	178	G	0.80	83.9	1.15
	6SME 300T	30	22	6000	3445	42.3	47.2	233	G	0.79	84.4	1.15
	6SME 400T	40	30	6000	3455	55.6	62.5	336	H	0.78	86.1	1.15
	6SME 500T	50	37	13849	3425	70.3	79.5	432	H	0.79	84.1	1.15
	6SME 600T	60	45	13849	3390	84.0	95.5	522	H	0.80	83.3	1.15
	6SME 750T	75	55	13849	3415	102.7	116.5	641	H	0.81	84.4	1.15

6" 60 HZ SERIES

Technical DETAILS

Size & Dimensions Motor Leads @ 60 Hz - 380/460 Volt

Sr: No.	Volt	Motor Size		Lead Size			Dimension B x H (inch)	Cable Length (Feet)	Qty (Nr.)
		HP	kW	Core	mm ²	AWG			
DOL	380V	5.5 ~ 30	4 ~ 22	3	6	10	0.75 x 0.31	13	1
				1	12	6			
	460V	5.5 ~ 30	4 ~ 22	3	10	8	0.95 x 0.35	13	1
				1	12	6			
3	460V	60 ~ 75	45 ~ 55	1	16*	6	D = 0.45	13	3
				1	12	6			
SD	380V	5.5 ~ 60	4 ~ 45	3	6	10	0.75 x 0.31	13	2
				1	12	6			
	460V	5.5 ~ 60	4 ~ 45	1	12	6	D = 0.27	13	1

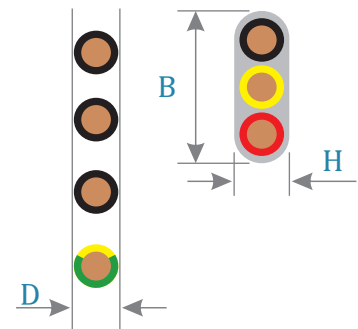

* 1 x 16 mm² as black color used for all three (3) wires.

Motor Performance Curve

tolerances according to NEMA standard and IEC 60034-1

5.5 HP | **4.1** kW | **208** Volt | **60** Hertz | **2** Pole

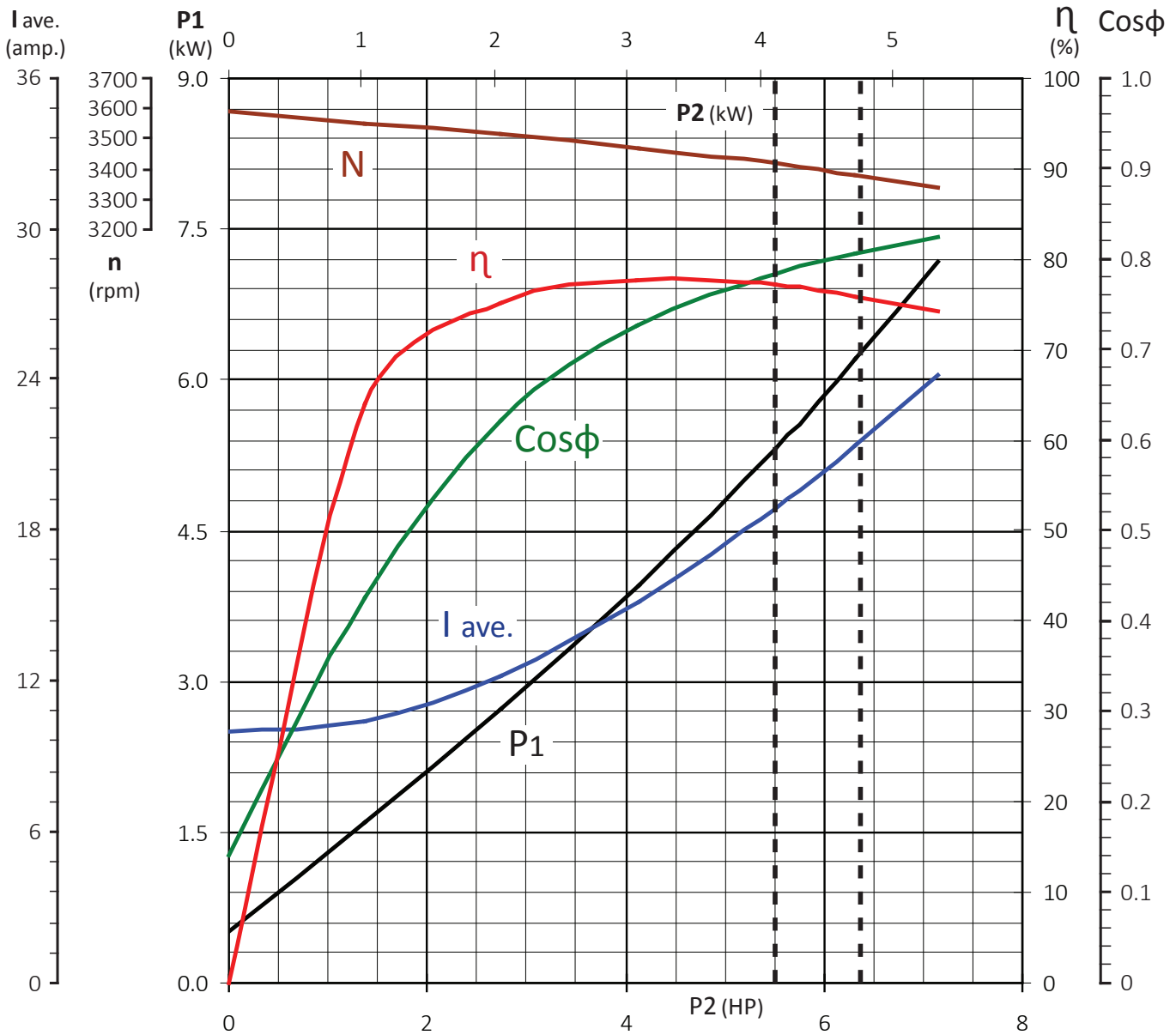

6" 60 HZ SERIES

Load	Frequency Hz	Volt ave. V	I ave. A	P1 kW	P1 HP	RPM	Torque Nm	P2 kW	P2 HP	Efficiency %	Cos pi
0%	60.00	208.0	10.04	0.51	0.68	3589.3	0.00	0.00	0.00	0.00%	0.141
25%	60.00	208.0	10.40	1.60	2.14	3547.9	2.76	1.03	1.38	64.11%	0.427
50%	60.00	208.0	12.20	2.73	3.66	3512.8	5.58	2.05	2.75	75.15%	0.621
75%	60.00	208.0	15.14	3.96	5.31	3469.7	8.47	3.08	4.13	77.71%	0.726
100%	60.00	208.0	18.84	5.32	7.13	3420.2	11.46	4.10	5.50	77.12%	0.784
115%	60.00	208.0	21.39	6.22	8.34	3378.8	13.34	4.72	6.33	75.86%	0.807
130%	60.00	208.0	24.16	7.18	9.62	3335.6	15.27	5.33	7.15	74.29%	0.825

Motor Performance Curve

tolerances according to NEMA standard and IEC 60034-1

7.5 HP | **5.6** kW | **208** Volt | **60** Hertz | **2** Pole

6" 60 HZ SERIES

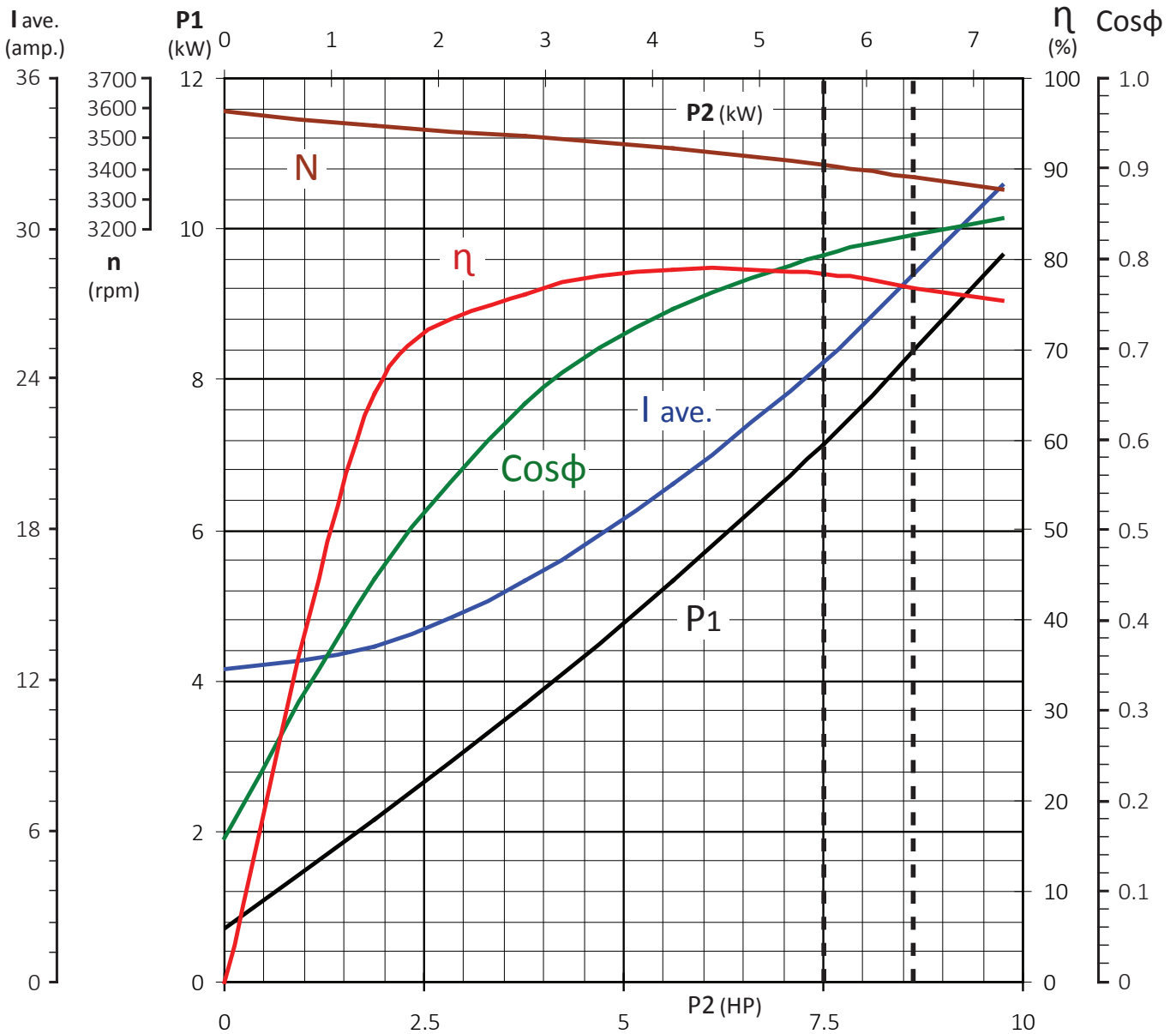

Load	Frequency Hz	Volt ave. V	I ave. A	P1 kW	P1 HP	RPM	Torque Nm	P2 kW	P2 HP	Efficiency %	Cos pi
0%	60.00	208.0	12.49	0.72	0.97	3588.8	0.00	0.00	0.00	0.00%	0.160
25%	60.00	208.0	13.38	2.15	2.88	3546.2	3.77	1.40	1.88	65.06%	0.446
50%	60.00	208.0	15.96	3.68	4.93	3510.1	7.61	2.80	3.75	76.02%	0.640
75%	60.00	208.0	19.86	5.33	7.14	3465.7	11.56	4.20	5.63	78.73%	0.745
100%	60.00	208.0	24.68	7.14	9.57	3414.8	15.65	5.60	7.50	78.36%	0.803
115%	60.00	208.0	28.19	8.39	11.25	3372.2	18.22	6.43	8.63	76.69%	0.826
130%	60.00	208.0	31.74	9.65	12.94	3327.8	20.87	7.27	9.75	75.37%	0.844

Motor Performance Curve

tolerances according to NEMA standard and IEC 60034-1

10 HP | **7.5** kW | **208** Volt | **60** Hertz | **2** Pole

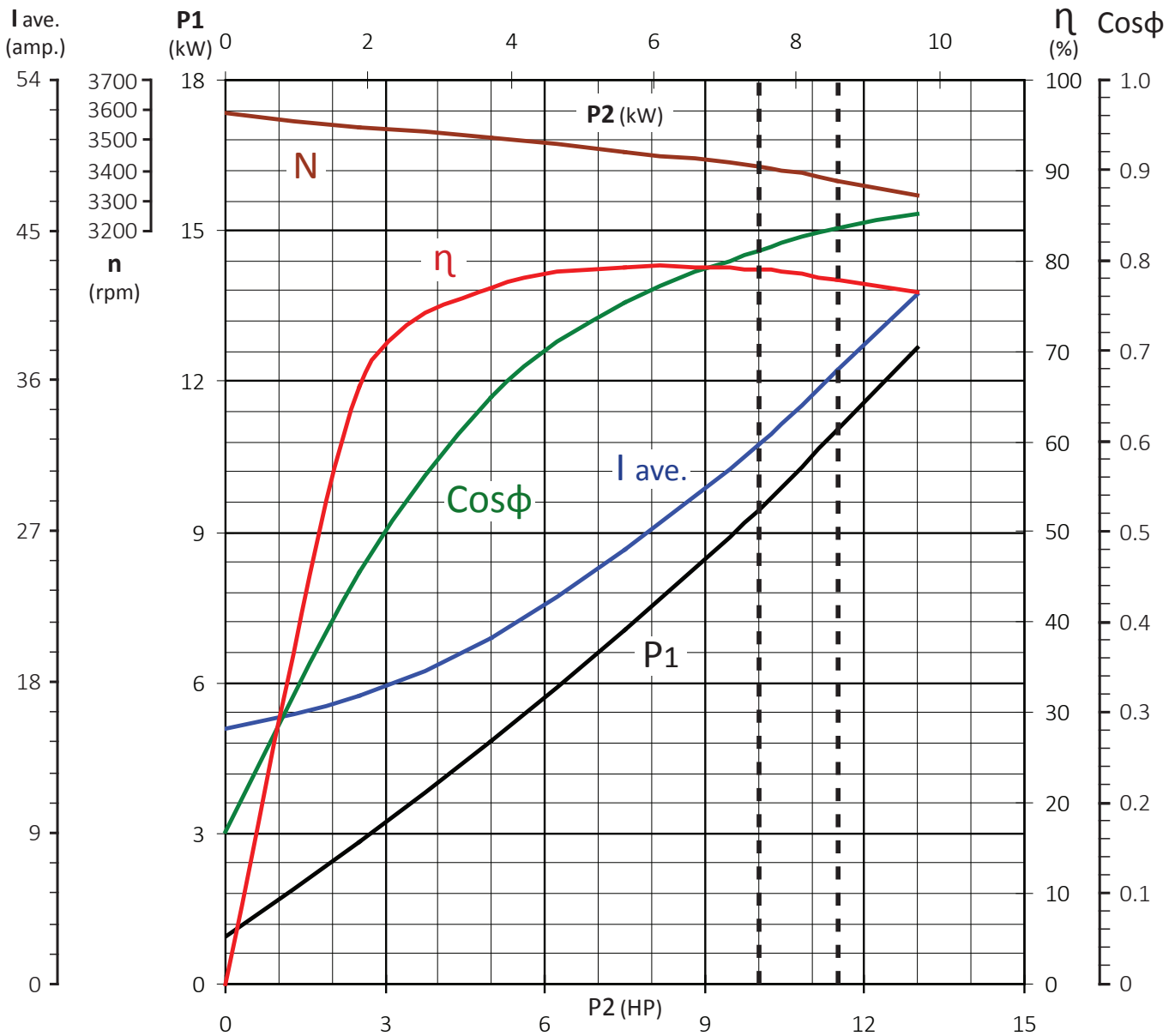

6" 60 HZ SERIES

Load	Frequency Hz	Volt ave. V	I ave. A	P1 kW	P1 HP	RPM	Torque Nm	P2 kW	P2 HP	Efficiency %	Cos pi
0%	60.00	208.0	15.28	0.93	1.25	3588.5	0.00	0.00	0.00	0.00%	0.169
25%	60.00	208.0	17.20	2.82	3.78	3544.8	5.02	1.87	2.50	66.13%	0.455
50%	60.00	208.0	20.70	4.84	6.49	3507.7	10.15	3.73	5.00	77.07%	0.649
75%	60.00	208.0	25.95	7.05	9.45	3462.1	15.43	5.60	7.50	79.36%	0.754
100%	60.00	208.0	32.27	9.44	12.65	3409.8	20.89	7.46	10.00	79.03%	0.812
115%	60.00	208.0	36.60	11.01	14.76	3366.1	24.34	8.58	11.50	77.92%	0.835
130%	60.00	208.0	41.20	12.66	16.97	3320.5	27.89	9.70	13.00	76.60%	0.853

Motor Performance Curve

tolerances according to NEMA standard and IEC 60034-1

15 HP | **11.2** kW | **208** Volt | **60** Hertz | **2** Pole

6" 60 HZ SERIES

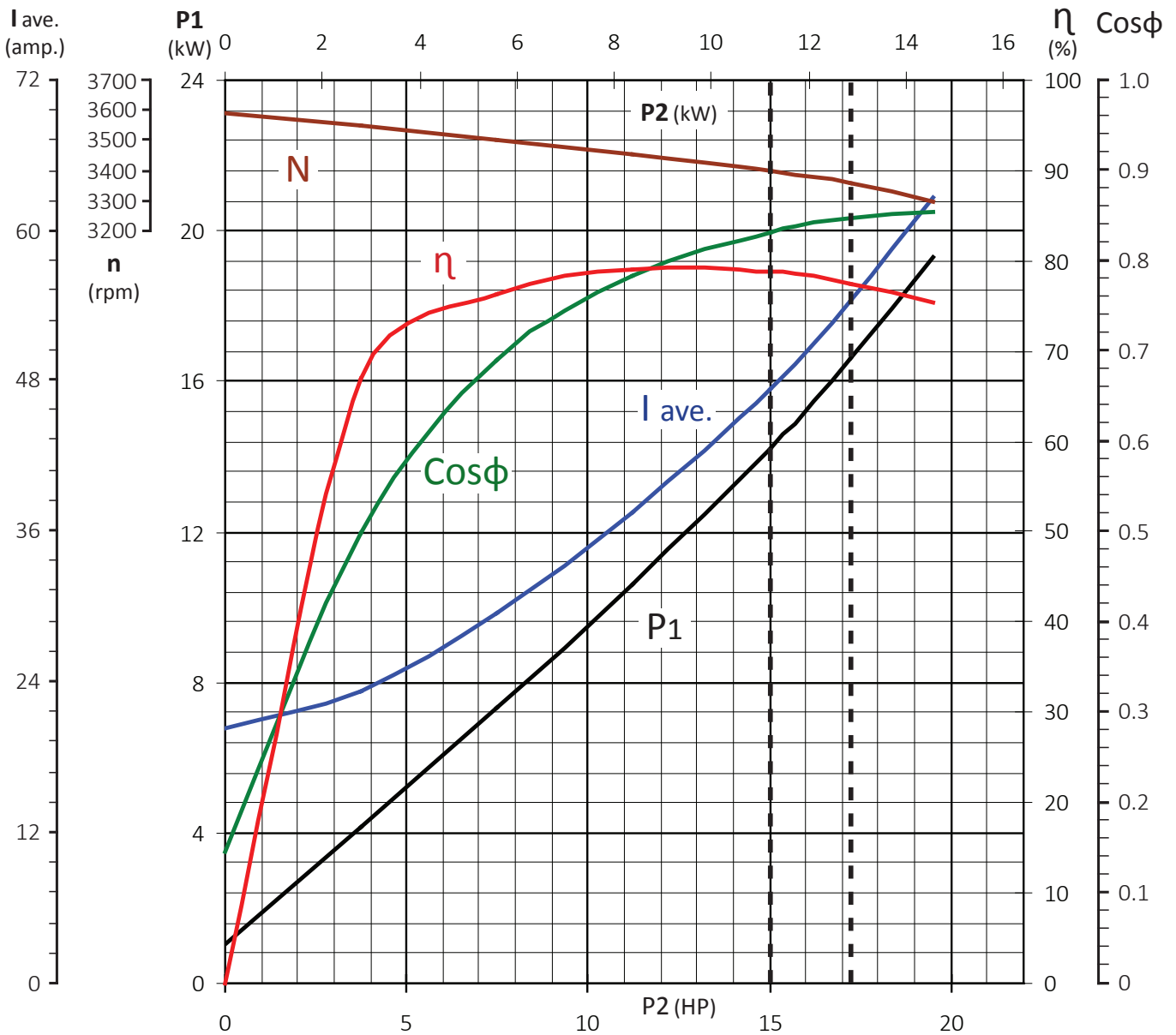

Load	Frequency Hz	Volt ave. V	I ave. A	P1 kW	P1 HP	RPM	Torque Nm	P2 kW	P2 HP	Efficiency %	Cos pi
0%	60.00	208.0	20.29	1.06	1.42	3593.0	0.00	0.00	0.00	0.00%	0.145
25%	60.00	208.0	23.25	4.18	5.60	3547.8	7.53	2.80	3.75	66.93%	0.499
50%	60.00	208.0	29.53	7.34	9.84	3502.8	15.25	5.60	7.50	76.23%	0.690
75%	60.00	208.0	37.60	10.62	14.24	3455.7	23.19	8.39	11.25	79.03%	0.784
100%	60.00	208.0	47.47	14.21	19.05	3399.7	31.43	11.19	15.00	78.75%	0.831
115%	60.00	208.0	54.47	16.62	22.28	3355.7	36.62	12.87	17.25	77.43%	0.847
130%	60.00	208.0	62.63	19.29	25.86	3299.6	42.10	14.55	19.50	75.41%	0.855

Motor Performance Curve

tolerances according to NEMA standard and IEC 60034-1

20 HP | **14.9** kW | **208** Volt | **60** Hertz | **2** Pole

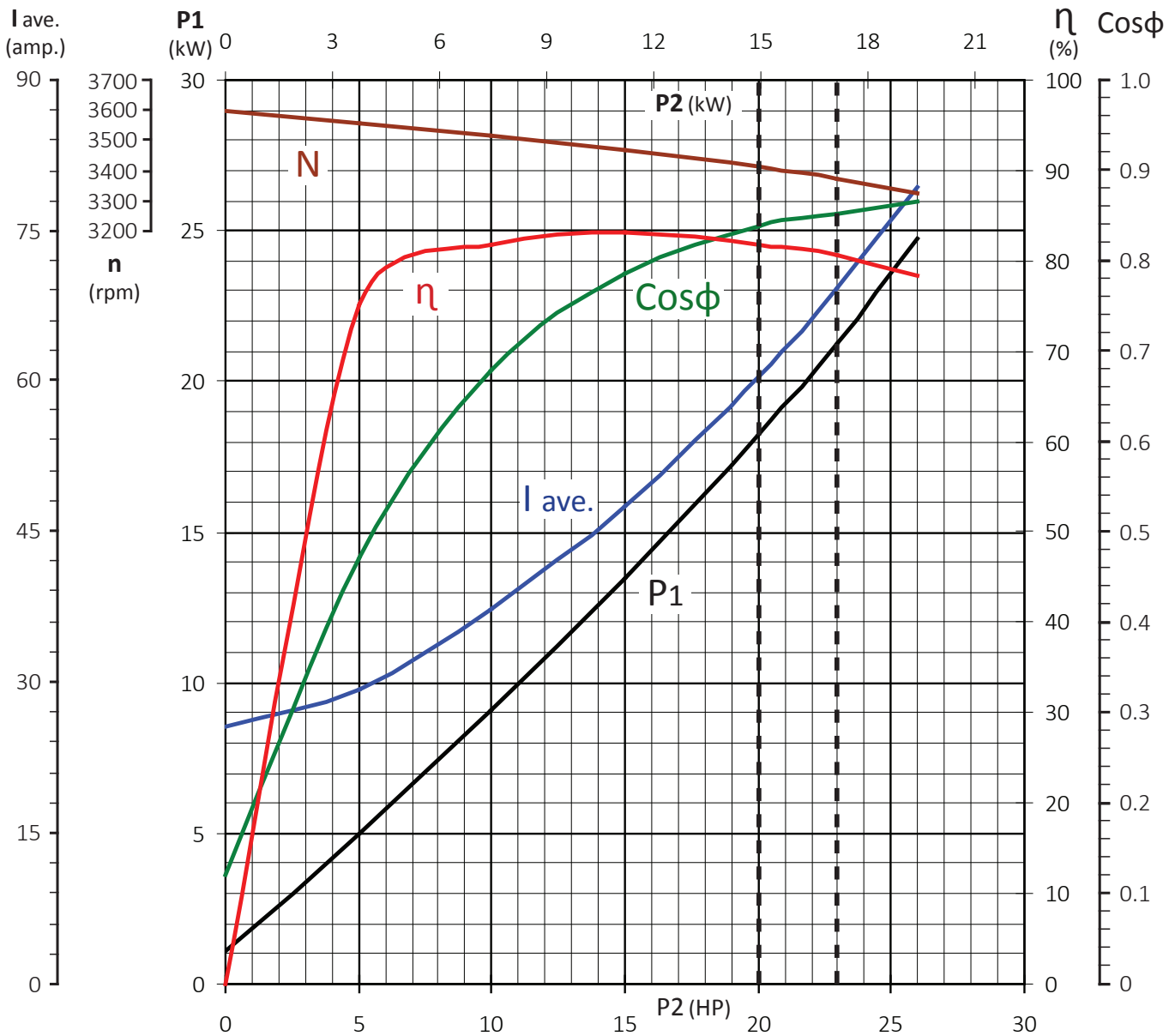

6" 60 HZ SERIES

Load	Frequency Hz	Volt ave. V	I ave. A	P1 kW	P1 HP	RPM	Torque Nm	P2 kW	P2 HP	Efficiency %	Cos pi
0%	60.00	208.0	25.69	1.12	1.50	3595.5	0.00	0.00	0.00	0.00%	0.121
25%	60.00	208.0	29.23	4.96	6.65	3556.3	10.02	3.73	5.00	75.20%	0.471
50%	60.00	208.0	37.28	9.12	12.23	3514.1	20.27	7.46	10.00	81.80%	0.679
75%	60.00	208.0	47.50	13.45	18.03	3470.7	30.79	11.19	15.00	83.20%	0.786
100%	60.00	208.0	60.45	18.25	24.46	3415.2	41.72	14.92	20.00	81.75%	0.838
115%	60.00	208.0	69.30	21.27	28.51	3372.7	48.58	17.16	23.00	80.67%	0.852
130%	60.00	208.0	79.33	24.72	33.14	3320.9	55.77	19.40	26.00	78.46%	0.865

Motor Performance Curve

tolerances according to NEMA standard and IEC 60034-1

25 HP | **18.6** kW | **208** Volt | **60** Hertz | **2** Pole

6" 60 HZ SERIES

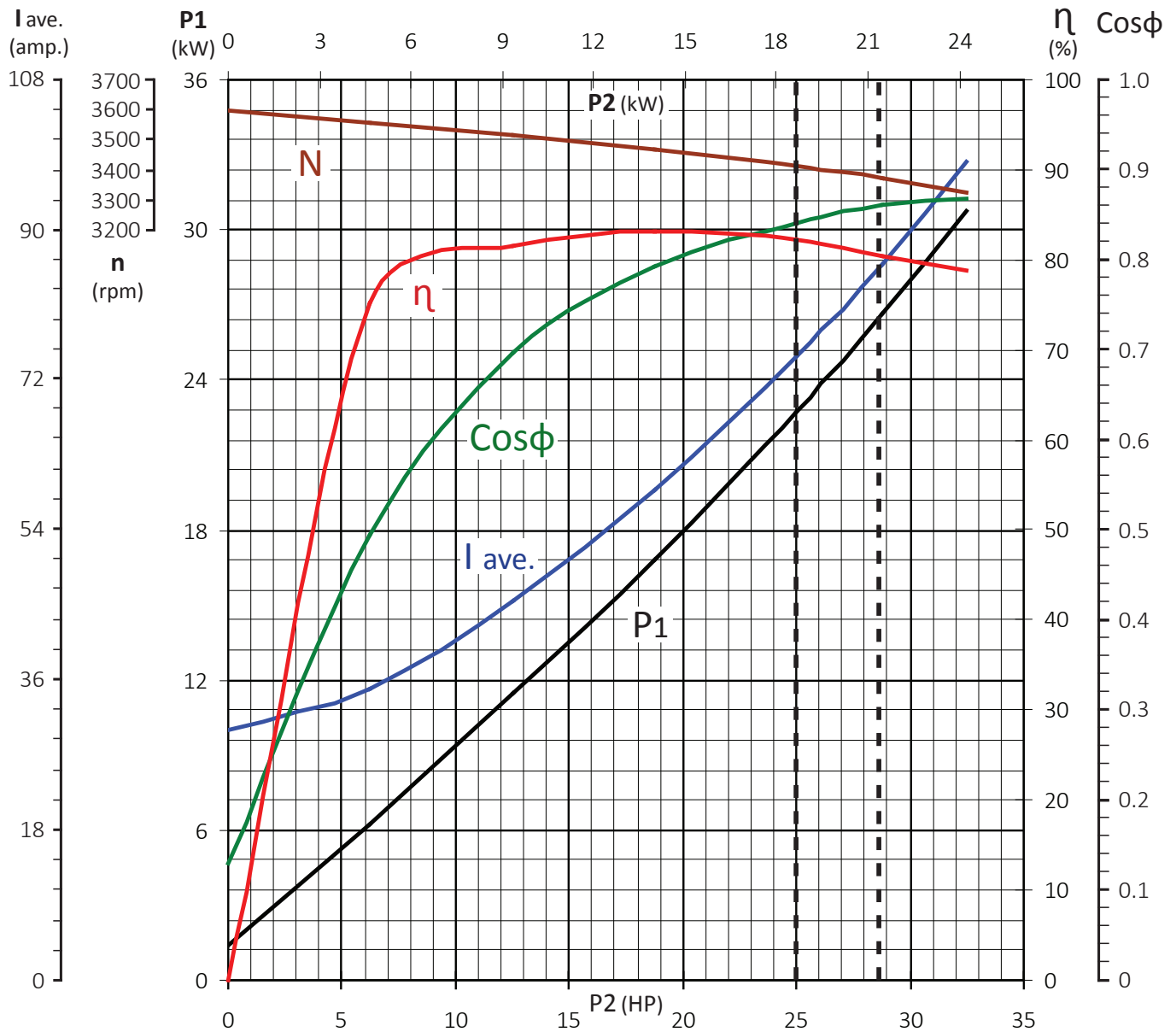

Load	Frequency Hz	Volt ave. V	I ave. A	P1 kW	P1 HP	RPM	Torque Nm	P2 kW	P2 HP	Efficiency %	Cos pi
0%	60.00	208.0	29.91	1.39	1.86	3594.2	0.00	0.00	0.00	0.00%	0.129
25%	60.00	208.0	34.82	6.21	8.32	3557.4	12.52	4.66	6.25	75.08%	0.495
50%	60.00	208.0	45.53	11.45	15.35	3514.8	25.33	9.33	12.50	81.44%	0.698
75%	60.00	208.0	58.88	16.82	22.55	3470.4	38.49	13.99	18.75	83.16%	0.793
100%	60.00	208.0	74.86	22.68	30.40	3414.9	52.15	18.65	25.00	82.23%	0.841
115%	60.00	208.0	85.82	26.65	35.72	3373.3	60.72	21.45	28.75	80.48%	0.862
130%	60.00	208.0	98.13	30.72	41.18	3322.2	69.69	24.25	32.50	78.92%	0.869

Motor Performance Curve

tolerances according to NEMA standard and IEC 60034-1

30 HP | **22.4** kW | **208** Volt | **60** Hertz | **2** Pole

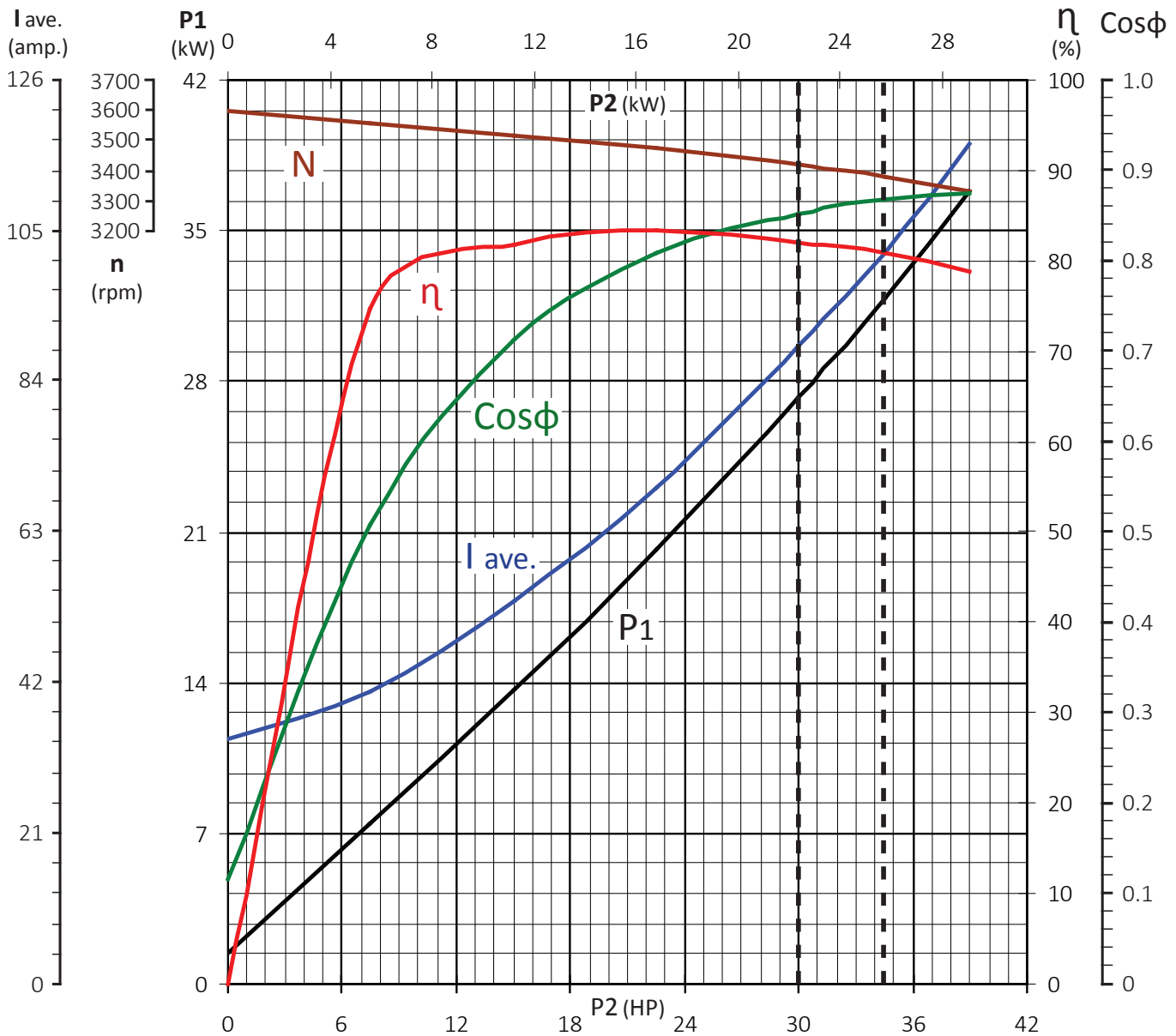

6" 60 HZ SERIES

Load	Frequency Hz	Volt ave. V	I ave. A	P1 kW	P1 HP	RPM	Torque Nm	P2 kW	P2 HP	Efficiency %	Cos pi
0%	60.00	208.0	34.22	1.43	1.92	3595.2	0.00	0.00	0.00	0.00%	0.116
25%	60.00	208.0	40.85	7.49	10.04	3556.5	15.02	5.60	7.50	74.70%	0.509
50%	60.00	208.0	53.37	13.69	18.35	3516.4	30.39	11.19	15.00	81.74%	0.712
75%	60.00	208.0	69.19	20.14	27.00	3471.2	46.18	16.79	22.50	83.34%	0.808
100%	60.00	208.0	88.88	27.28	36.57	3420.1	62.49	22.38	30.00	82.04%	0.852
115%	60.00	208.0	102.00	31.86	42.71	3378.7	72.74	25.74	34.50	80.78%	0.867
130%	60.00	208.0	116.96	36.87	49.42	3334.1	83.33	29.09	39.00	78.91%	0.875

Motor Performance Curve

tolerances according to NEMA standard and IEC 60034-1

40 HP | **29.8** kW | **208** Volt | **60** Hertz | **2** Pole

6" 60 HZ SERIES

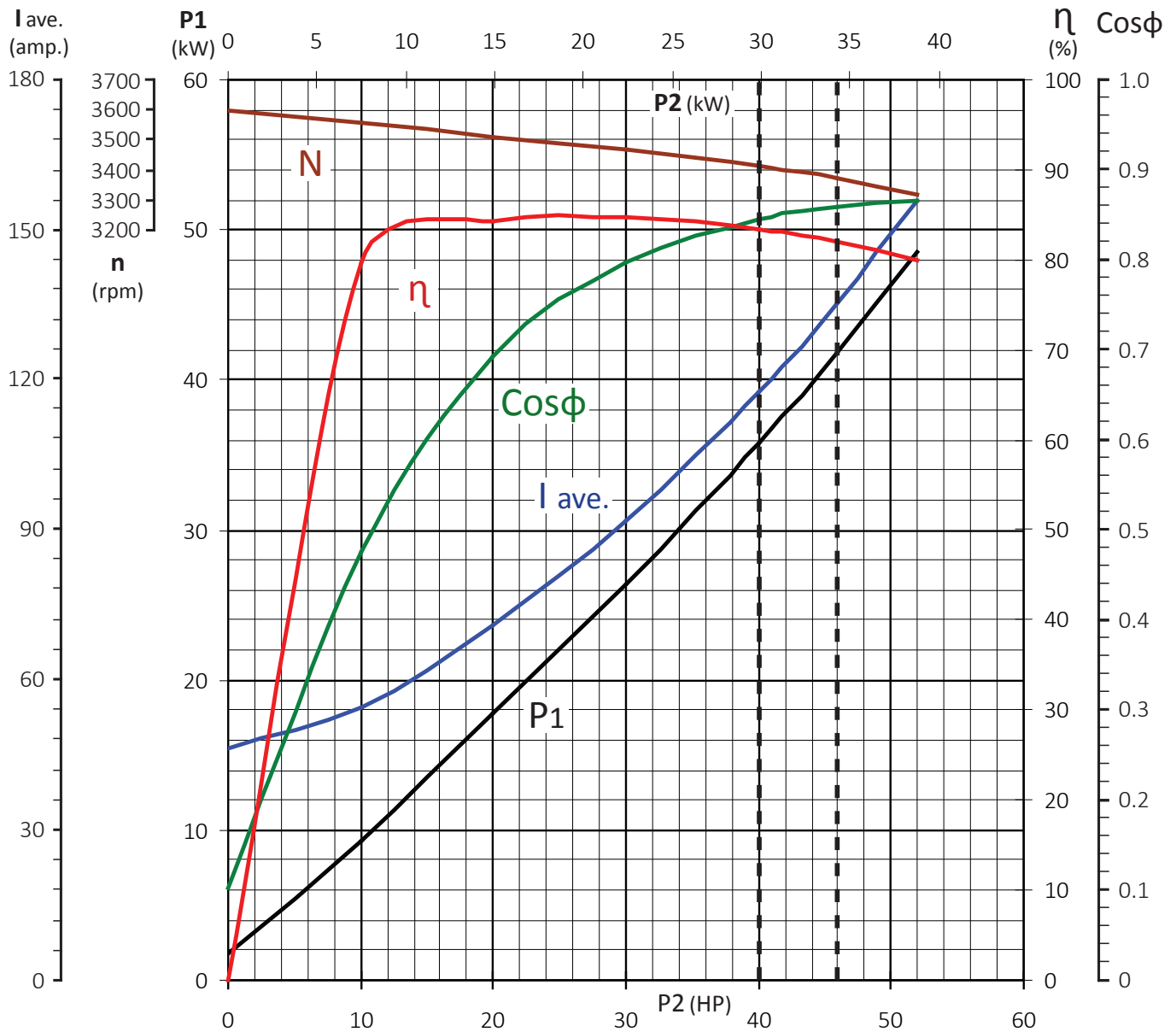

Load	Frequency Hz	Volt ave. V	I ave. A	P1 kW	P1 HP	RPM	Torque Nm	P2 kW	P2 HP	Efficiency %	Cos pi
0%	60.00	208.0	46.54	1.71	2.29	3597.6	0.00	0.00	0.00	0.00%	0.102
25%	60.00	208.0	54.70	9.36	12.55	3557.2	20.03	7.46	10.00	79.70%	0.475
50%	60.00	208.0	71.08	17.72	23.75	3509.1	40.60	14.92	20.00	84.20%	0.692
75%	60.00	208.0	91.90	26.42	35.42	3468.3	61.62	22.38	30.00	84.71%	0.798
100%	60.00	208.0	117.74	35.80	47.99	3414.6	83.45	29.84	40.00	83.35%	0.844
115%	60.00	208.0	135.24	41.85	56.10	3369.3	97.26	34.32	46.00	82.00%	0.859
130%	60.00	208.0	155.70	48.52	65.04	3318.7	111.62	38.79	52.00	79.95%	0.865

Motor Performance Curve

tolerances according to NEMA standard and IEC 60034-1

5.5 HP | **4.1** kW | **230** Volt | **60** Hertz | **2** Pole

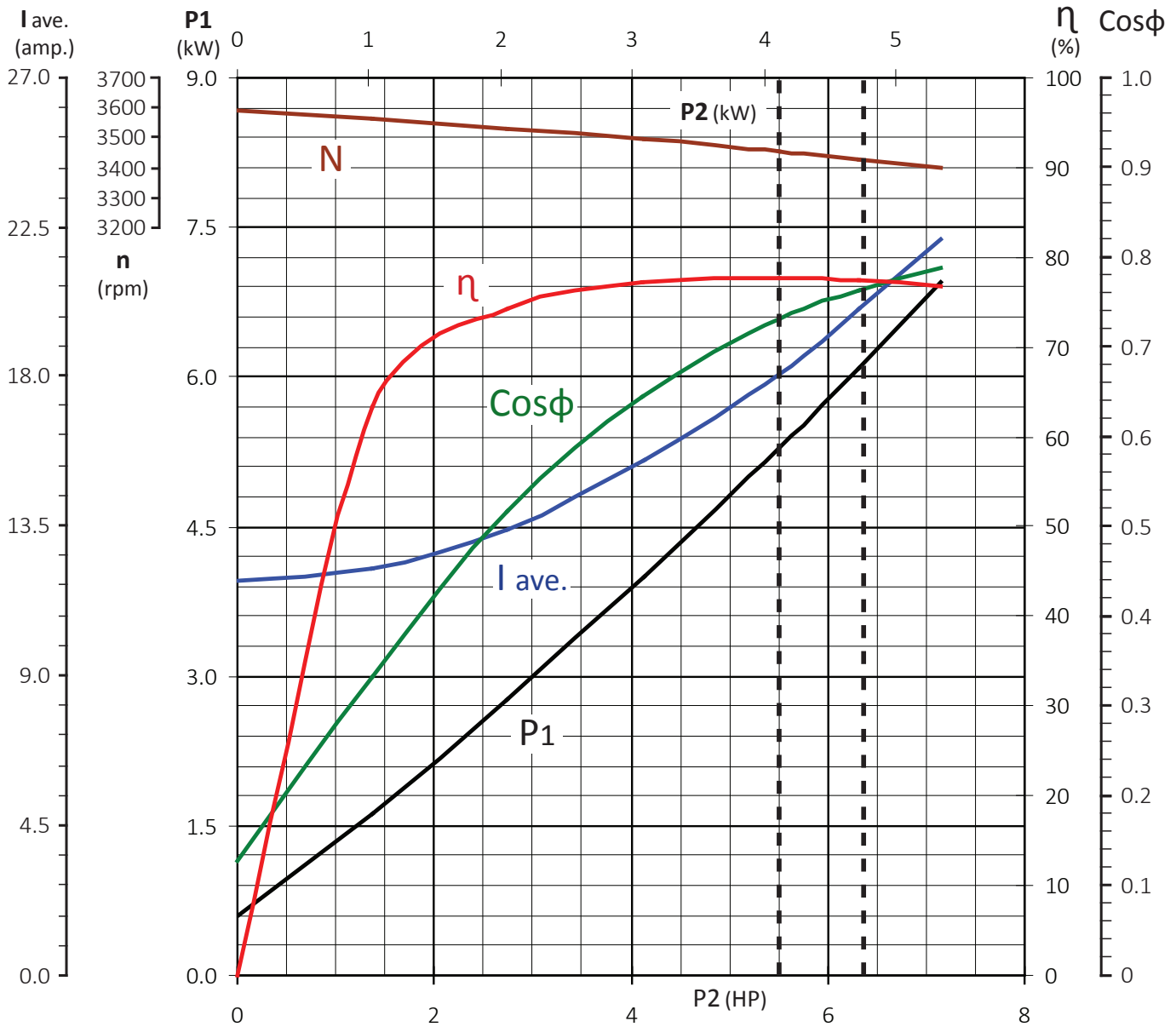

6" 60 HZ SERIES

Load	Frequency Hz	Volt ave. V	I ave. A	P1 kW	P1 HP	RPM	Torque Nm	P2 kW	P2 HP	Efficiency %	Cos pi
0%	60.00	230.0	11.86	0.60	0.80	3590.6	0.00	0.00	0.00	0.00%	0.127
25%	60.00	230.0	12.25	1.62	2.17	3561.7	2.75	1.03	1.38	63.32%	0.332
50%	60.00	230.0	13.40	2.76	3.70	3528.7	5.55	2.05	2.75	74.33%	0.517
75%	60.00	230.0	15.53	3.99	5.35	3493.7	8.41	3.08	4.13	77.12%	0.645
100%	60.00	230.0	18.11	5.28	7.08	3454.8	11.34	4.10	5.50	77.71%	0.732
115%	60.00	230.0	20.06	6.09	8.16	3428.7	13.14	4.72	6.33	77.48%	0.762
130%	60.00	230.0	22.14	6.95	9.32	3397.5	14.99	5.33	7.15	76.75%	0.788

Motor Performance Curve

tolerances according to NEMA standard and IEC 60034-1

7.5 HP | **5.6** kW | **230** Volt | **60** Hertz | **2** Pole

6" 60 HZ SERIES

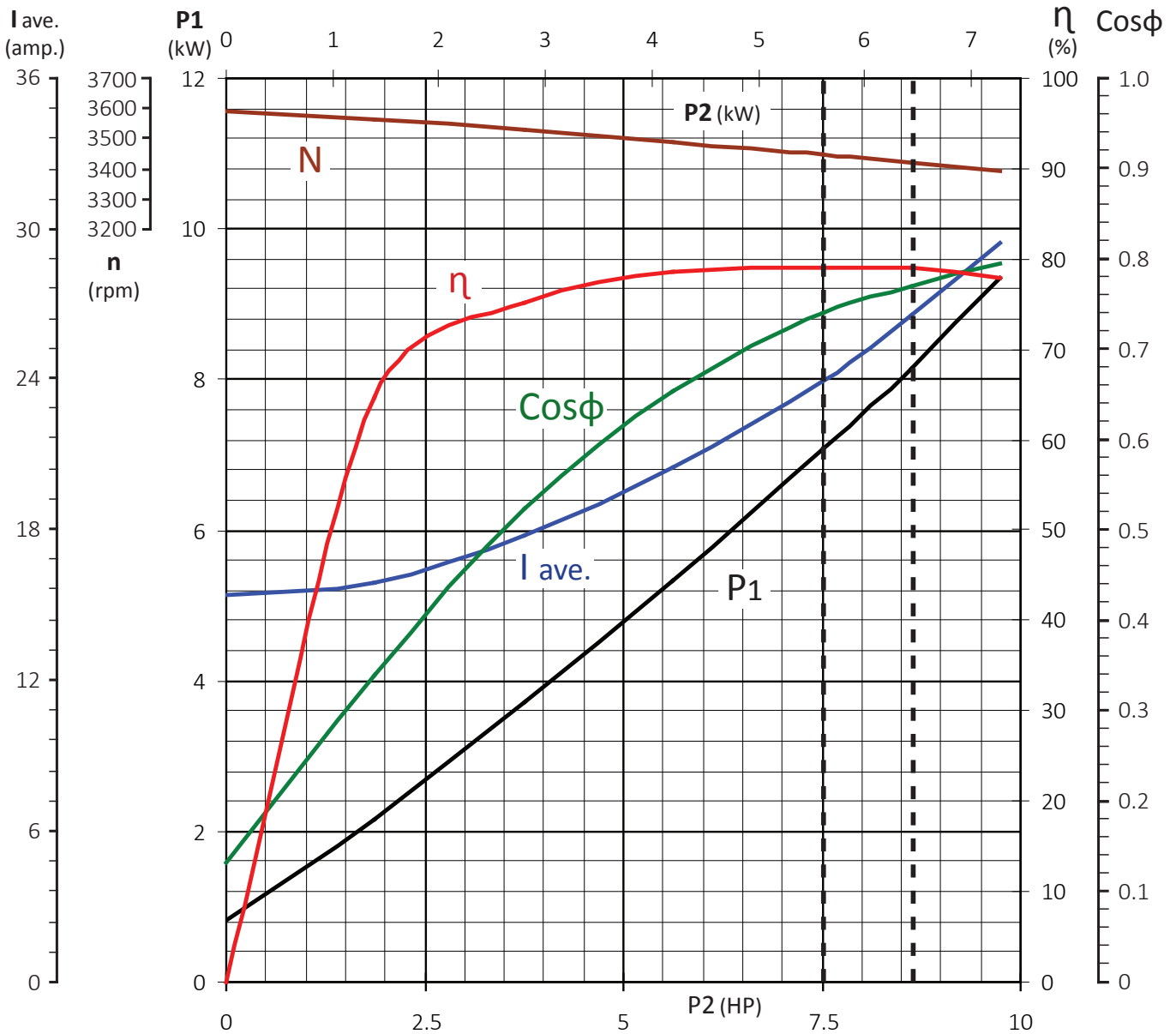

Load	Frequency Hz	Volt ave. V	I ave. A	P1 kW	P1 HP	RPM	Torque Nm	P2 kW	P2 HP	Efficiency %	Cos pi
0%	60.00	230.0	15.40	0.81	1.09	3590.5	0.00	0.00	0.00	0.00%	0.132
25%	60.00	230.0	15.95	2.16	2.90	3560.7	3.75	1.40	1.88	64.76%	0.340
50%	60.00	230.0	17.79	3.72	4.99	3526.5	7.58	2.80	3.75	75.20%	0.525
75%	60.00	230.0	20.53	5.34	7.16	3490.3	11.48	4.20	5.63	78.58%	0.653
100%	60.00	230.0	23.98	7.07	9.48	3450.2	15.49	5.60	7.50	79.14%	0.740
115%	60.00	230.0	26.54	8.14	10.91	3423.2	17.95	6.43	8.63	79.04%	0.770
130%	60.00	230.0	29.45	9.34	12.52	3390.9	20.48	7.27	9.75	77.87%	0.796

Motor Performance Curve

tolerances according to NEMA standard and IEC 60034-1

10 HP | **7.5** kW | **230** Volt | **60** Hertz | **2** Pole

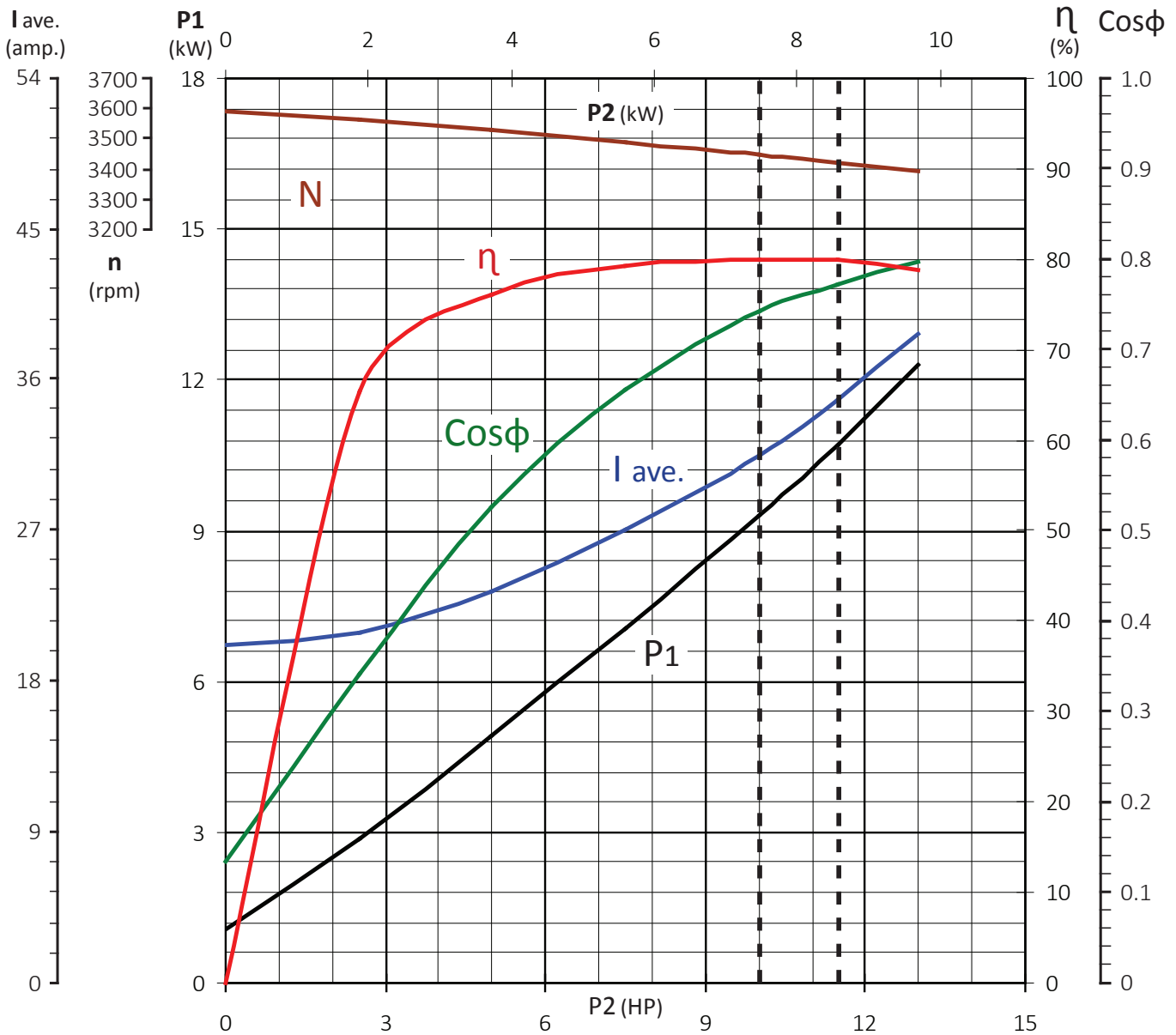

6" 60 HZ SERIES

Load	Frequency Hz	Volt ave. V	I ave. A	P1 kW	P1 HP	RPM	Torque Nm	P2 kW	P2 HP	Efficiency %	Cos pi
0%	60.00	230.0	20.23	1.08	1.45	3590.4	0.00	0.00	0.00	0.00%	0.134
25%	60.00	230.0	20.92	2.85	3.82	3560.5	5.00	1.87	2.50	65.44%	0.342
50%	60.00	230.0	23.34	4.90	6.57	3526.3	10.10	3.73	5.00	76.12%	0.527
75%	60.00	230.0	27.02	7.05	9.45	3490.2	15.31	5.60	7.50	79.36%	0.655
100%	60.00	230.0	31.53	9.32	12.49	3450.0	20.65	7.46	10.00	80.04%	0.742
115%	60.00	230.0	34.86	10.72	14.37	3422.9	23.93	8.58	11.50	80.03%	0.772
130%	60.00	230.0	38.76	12.32	16.51	3390.7	27.31	9.70	13.00	78.72%	0.798

Motor Performance Curve

tolerances according to NEMA standard and IEC 60034-1

15 HP | **11.2** kW | **230** Volt | **60** Hertz | **2** Pole

6" 60 HZ SERIES

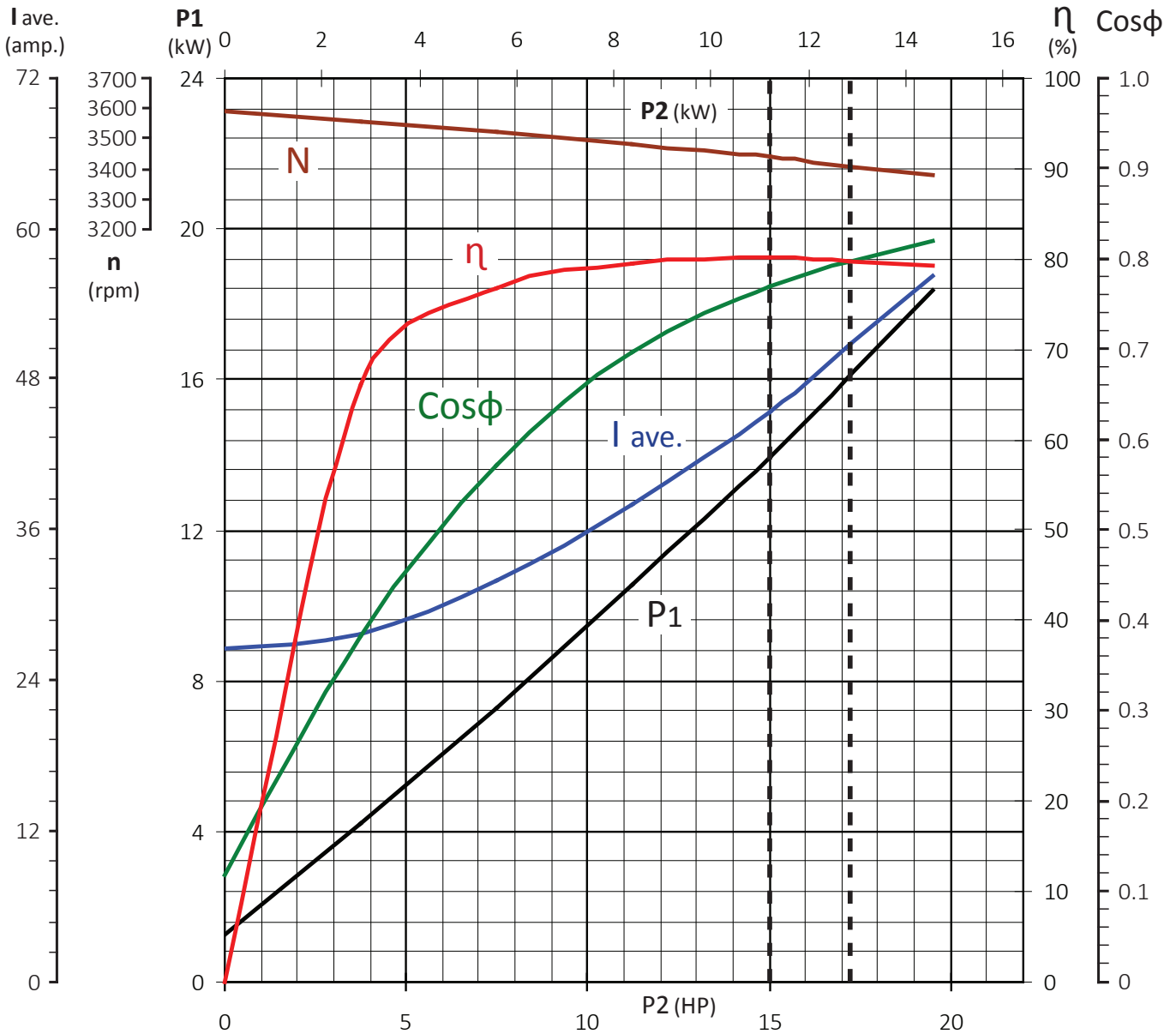

Load	Frequency Hz	Volt ave. V	I ave. A	P1 kW	P1 HP	RPM	Torque Nm	P2 kW	P2 HP	Efficiency %	Cos pi
0%	60.00	230.0	26.58	1.26	1.69	3592.1	0.00	0.00	0.00	0.00%	0.119
25%	60.00	230.0	27.72	4.23	5.67	3558.6	7.51	2.80	3.75	66.13%	0.383
50%	60.00	230.0	31.95	7.28	9.76	3521.8	15.17	5.60	7.50	76.85%	0.572
75%	60.00	230.0	38.07	10.57	14.17	3484.2	23.00	8.39	11.25	79.40%	0.697
100%	60.00	230.0	45.48	13.95	18.70	3440.2	31.06	11.19	15.00	80.22%	0.770
115%	60.00	230.0	50.77	16.12	21.61	3409.1	36.05	12.87	17.25	79.83%	0.797
130%	60.00	230.0	56.24	18.35	24.60	3377.9	41.12	14.55	19.50	79.28%	0.819

Motor Performance Curve

tolerances according to NEMA standard and IEC 60034-1

20 HP | **14.9** kW | **230** Volt | **60** Hertz | **2** Pole

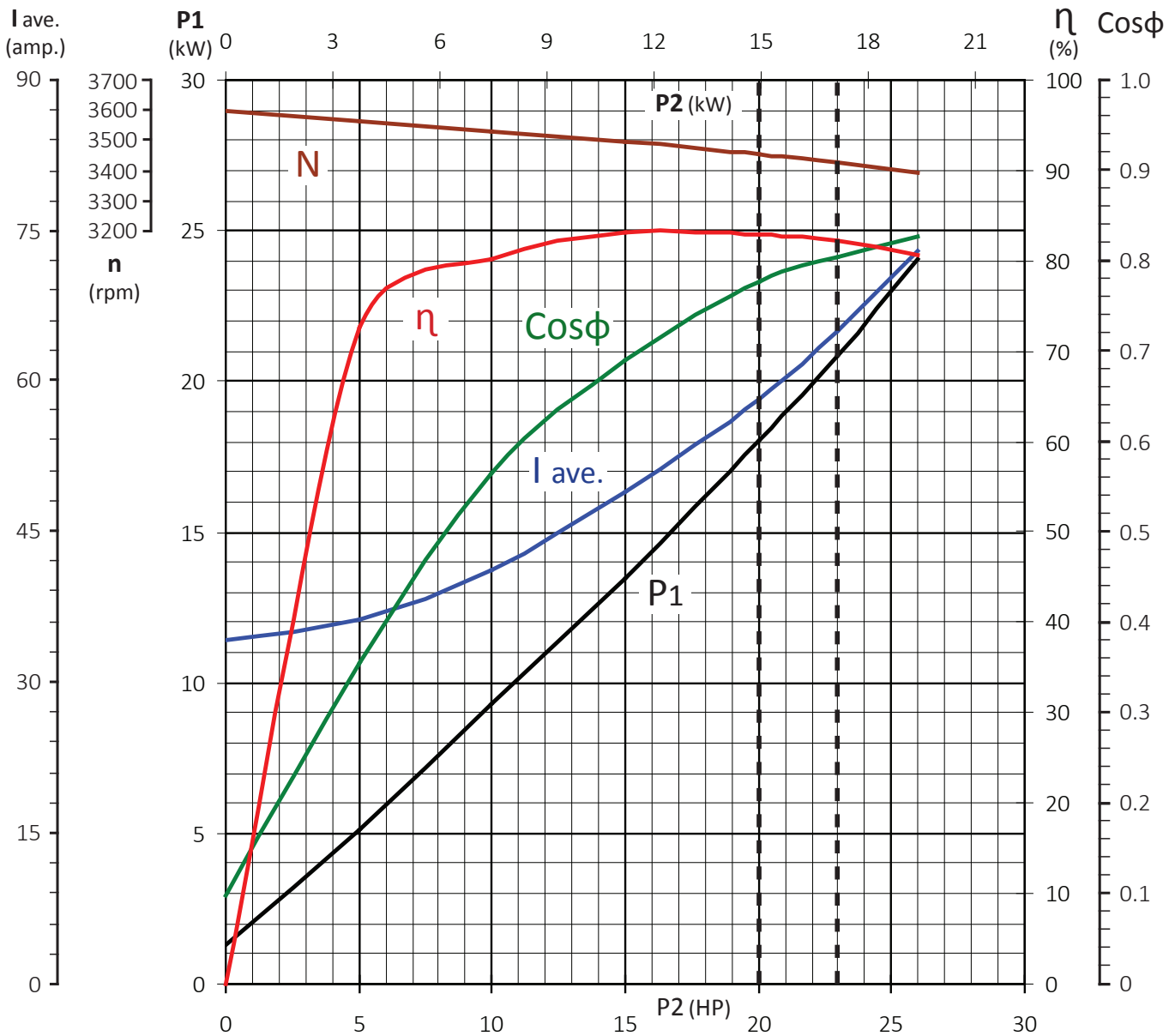

6" 60 HZ SERIES

Load	Frequency Hz	Volt ave. V	I ave. A	P1 kW	P1 HP	RPM	Torque Nm	P2 kW	P2 HP	Efficiency %	Cos pi
0%	60.00	230.0	34.16	1.32	1.77	3595.6	0.00	0.00	0.00	0.00%	0.097
25%	60.00	230.0	36.24	5.14	6.89	3564.9	9.99	3.73	5.00	72.57%	0.356
50%	60.00	230.0	41.29	9.31	12.48	3529.6	20.18	7.46	10.00	80.13%	0.566
75%	60.00	230.0	49.01	13.47	18.06	3492.3	30.60	11.19	15.00	83.07%	0.690
100%	60.00	230.0	58.26	18.01	24.14	3454.9	41.24	14.92	20.00	82.84%	0.776
115%	60.00	230.0	65.05	20.86	27.96	3425.9	47.83	17.16	23.00	82.25%	0.805
130%	60.00	230.0	73.00	24.05	32.24	3390.5	54.63	19.40	26.00	80.65%	0.827

Motor Performance Curve

tolerances according to NEMA standard and IEC 60034-1

25 HP | **18.6** kW | **230** Volt | **60** Hertz | **2** Pole

6" 60 HZ SERIES

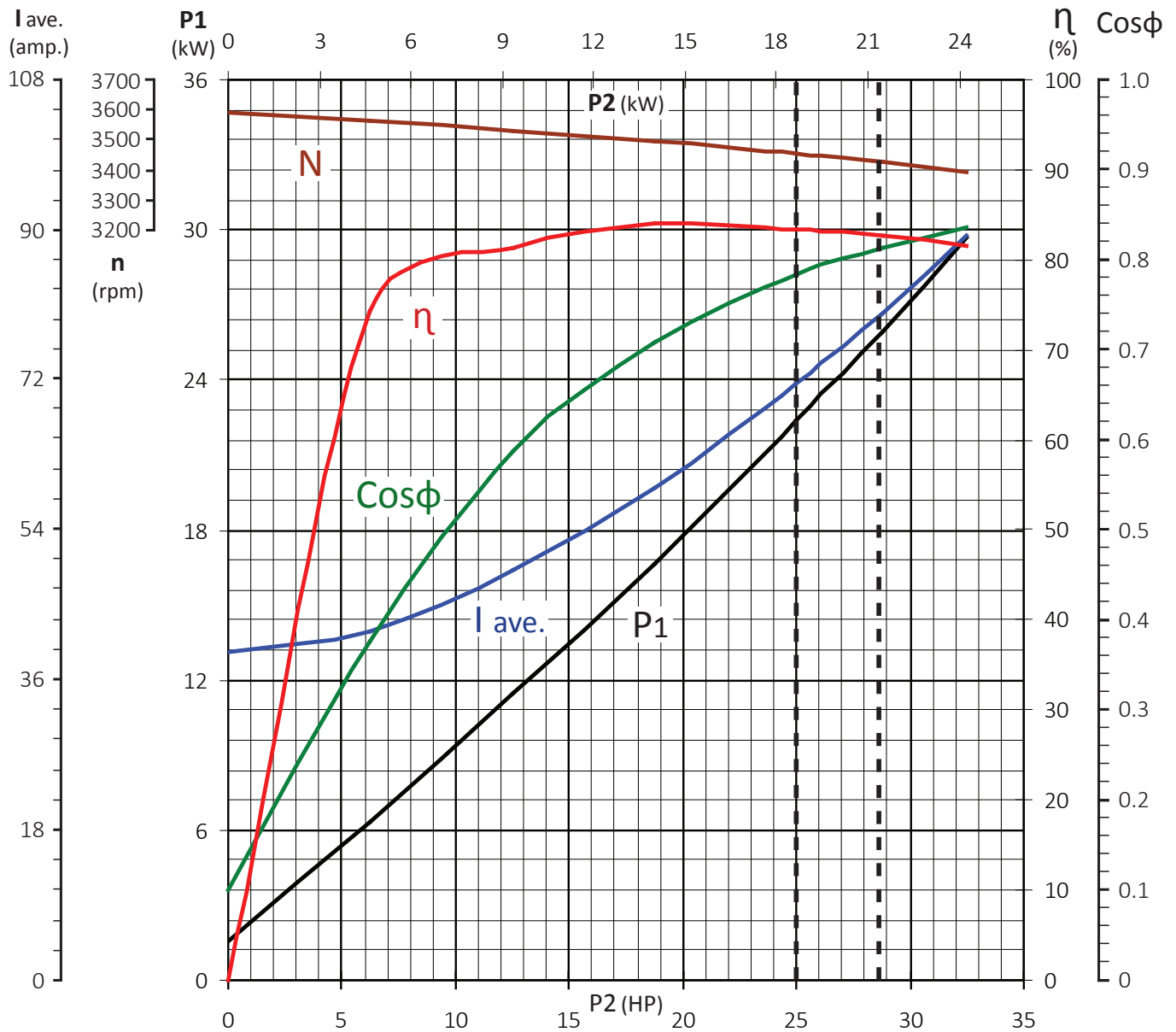

Load	Frequency Hz	Volt ave. V	I ave. A	P1 kW	P1 HP	RPM	Torque Nm	P2 kW	P2 HP	Efficiency %	Cos pi
0%	60.00	230.0	39.27	1.58	2.12	3593.8	0.00	0.00	0.00	0.00%	0.101
25%	60.00	230.0	41.93	6.28	8.42	3564.5	12.49	4.66	6.25	74.24%	0.376
50%	60.00	230.0	49.09	11.48	15.39	3529.8	25.23	9.33	12.50	81.23%	0.587
75%	60.00	230.0	59.00	16.64	22.31	3494.2	38.23	13.99	18.75	84.06%	0.708
100%	60.00	230.0	71.59	22.36	29.97	3455.1	51.55	18.65	25.00	83.41%	0.784
115%	60.00	230.0	80.00	25.91	34.73	3424.7	59.80	21.45	28.75	82.78%	0.813
130%	60.00	230.0	89.35	29.72	39.84	3395.0	68.20	24.25	32.50	81.58%	0.835

Motor Performance Curve

tolerances according to NEMA standard and IEC 60034-1

30 HP | **22.4** kW | **230** Volt | **60** Hertz | **2** Pole

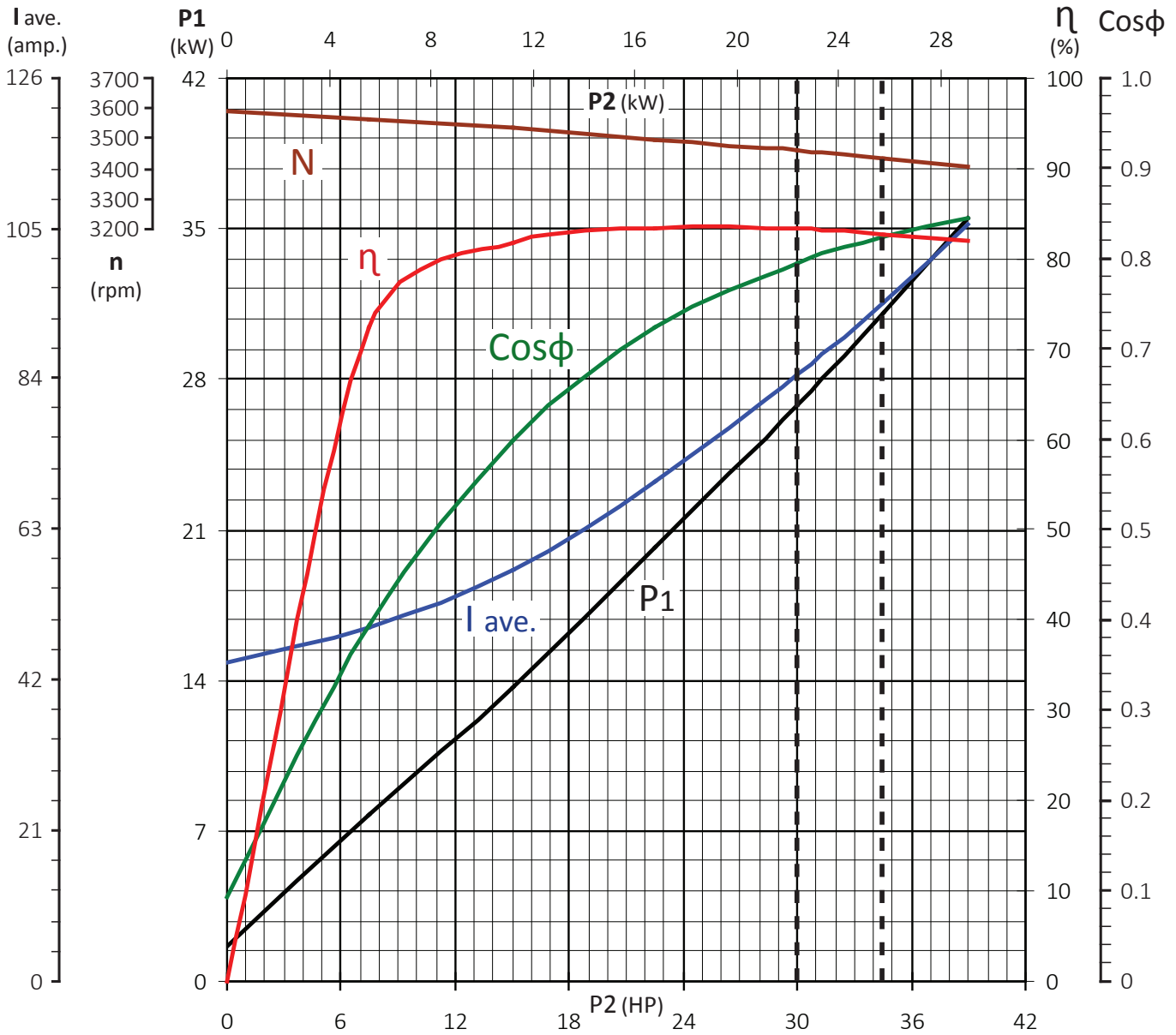

6" 60 HZ SERIES

Load	Frequency Hz	Volt ave. V	I ave. A	P1 kW	P1 HP	RPM	Torque Nm	P2 kW	P2 HP	Efficiency %	Cos pi
0%	60.00	230.0	44.60	1.67	2.24	3593.8	0.00	0.00	0.00	0.00%	0.094
25%	60.00	230.0	49.31	7.72	10.35	3562.8	15.00	5.60	7.50	72.47%	0.393
50%	60.00	230.0	57.51	13.70	18.36	3533.4	30.24	11.19	15.00	81.68%	0.598
75%	60.00	230.0	69.73	20.14	27.00	3494.6	45.87	16.79	22.50	83.34%	0.725
100%	60.00	230.0	84.61	26.83	35.97	3459.9	61.77	22.38	30.00	83.41%	0.796
115%	60.00	230.0	94.69	31.12	41.72	3435.4	71.54	25.74	34.50	82.70%	0.825
130%	60.00	230.0	105.65	35.52	47.61	3405.3	81.59	29.09	39.00	81.91%	0.844

Motor Performance Curve

tolerances according to NEMA standard and IEC 60034-1

40 HP | **29.8** kW | **230** Volt | **60** Hertz | **2** Pole

6" 60 HZ SERIES

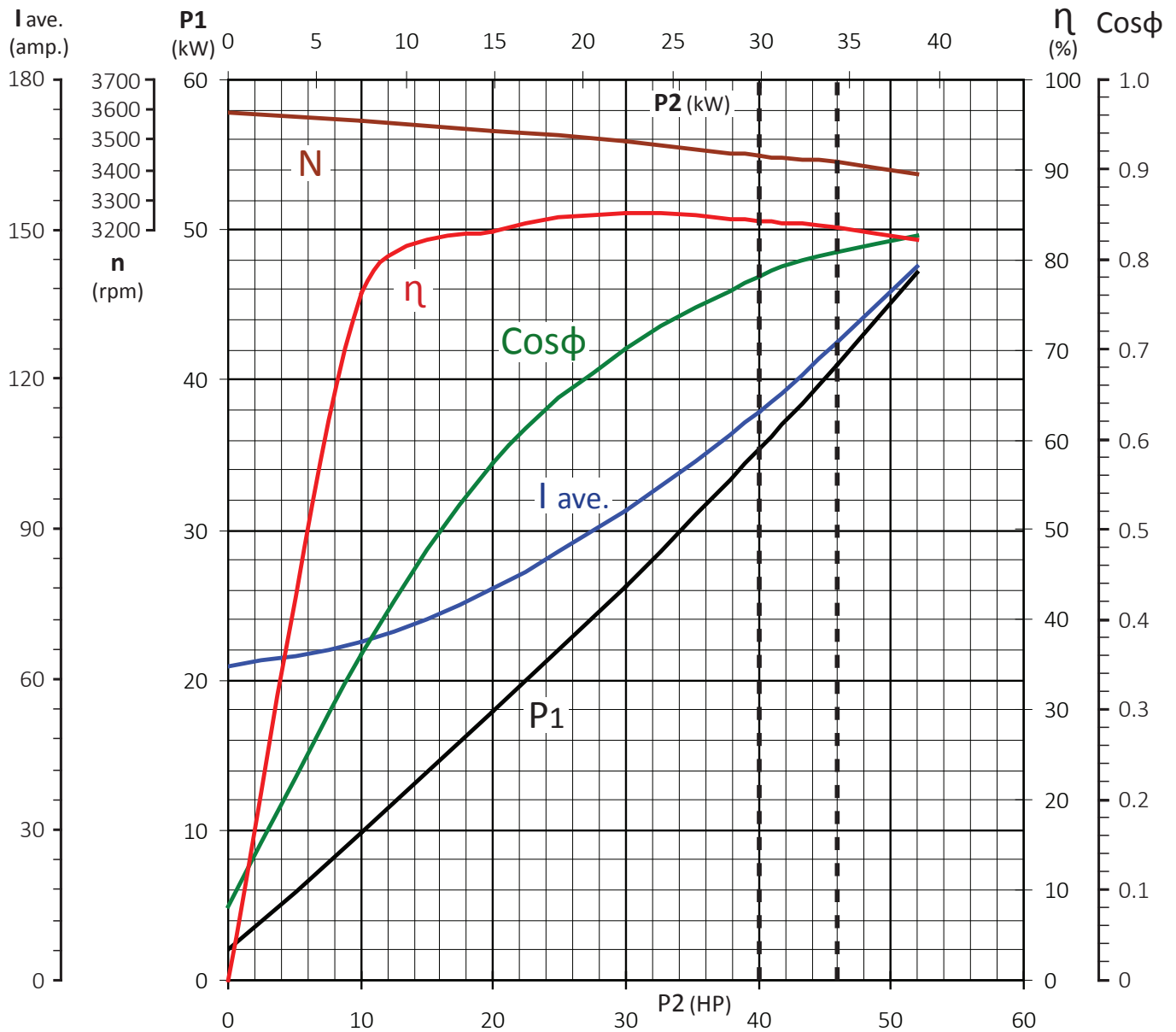

Load	Frequency Hz	Volt ave. V	I ave. A	P1 kW	P1 HP	RPM	Torque Nm	P2 kW	P2 HP	Efficiency %	Cos pi
0%	60.00	230.0	62.76	2.05	2.75	3589.3	0.00	0.00	0.00	0.00%	0.082
25%	60.00	230.0	67.82	9.78	13.11	3565.4	19.98	7.46	10.00	76.28%	0.362
50%	60.00	230.0	78.36	17.95	24.06	3530.7	40.35	14.92	20.00	83.12%	0.575
75%	60.00	230.0	93.90	26.26	35.20	3494.5	61.16	22.38	30.00	85.22%	0.702
100%	60.00	230.0	113.65	35.36	47.40	3450.2	82.59	29.84	40.00	84.39%	0.781
115%	60.00	230.0	127.38	41.05	55.03	3424.0	95.70	34.32	46.00	83.60%	0.809
130%	60.00	230.0	142.86	47.12	63.16	3388.5	109.32	38.79	52.00	82.33%	0.828

Motor Performance Curve

tolerances according to NEMA standard and IEC 60034-1

5.5 | **4.1** | **380** | **60** | **2**
 HP | kW | Volt | Hertz | Pole

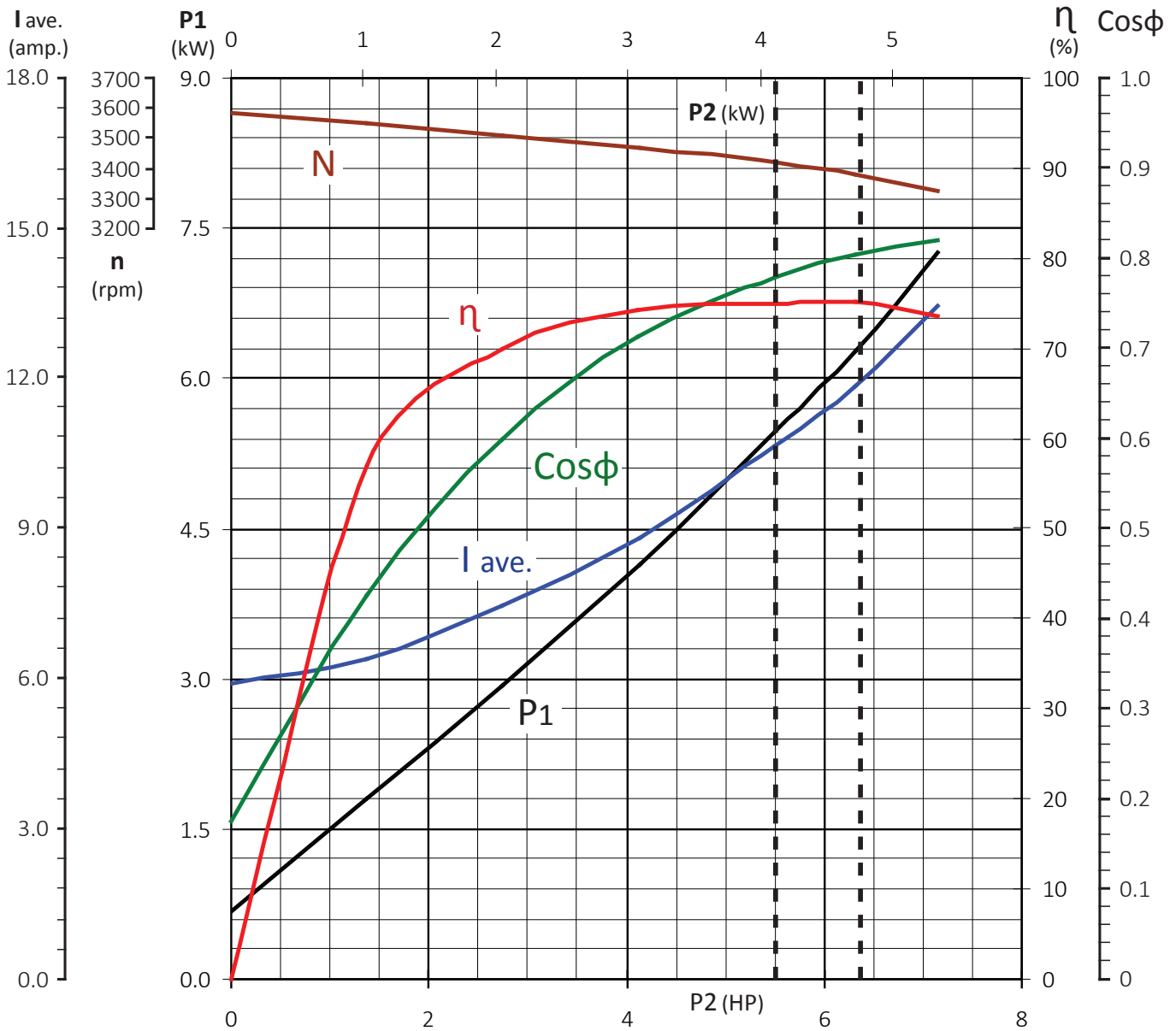

6" 60 HZ SERIES

Load	Frequency Hz	Volt ave. V	I ave. A	P1 kW	P1 HP	RPM	Torque Nm	P2 kW	P2 HP	Efficiency %	Cos pi
0%	60.00	380.0	5.91	0.68	0.92	3587.0	0.00	0.00	0.00	0.00%	0.176
25%	60.00	380.0	6.40	1.80	2.41	3551.4	2.76	1.03	1.38	57.02%	0.427
50%	60.00	380.0	7.46	2.93	3.93	3511.8	5.58	2.05	2.75	69.91%	0.598
75%	60.00	380.0	8.83	4.15	5.56	3469.5	8.47	3.08	4.13	74.20%	0.714
100%	60.00	380.0	10.68	5.47	7.33	3420.0	11.46	4.10	5.50	75.06%	0.778
115%	60.00	380.0	11.86	6.27	8.40	3381.2	13.33	4.72	6.33	75.28%	0.803
130%	60.00	380.0	13.43	7.26	9.73	3325.8	15.32	5.33	7.15	73.48%	0.821

Motor Performance Curve

tolerances according to NEMA standard and IEC 60034-1

7.5 HP | **5.6** kW | **380** Volt | **60** Hertz | **2** Pole

6" 60 HZ SERIES

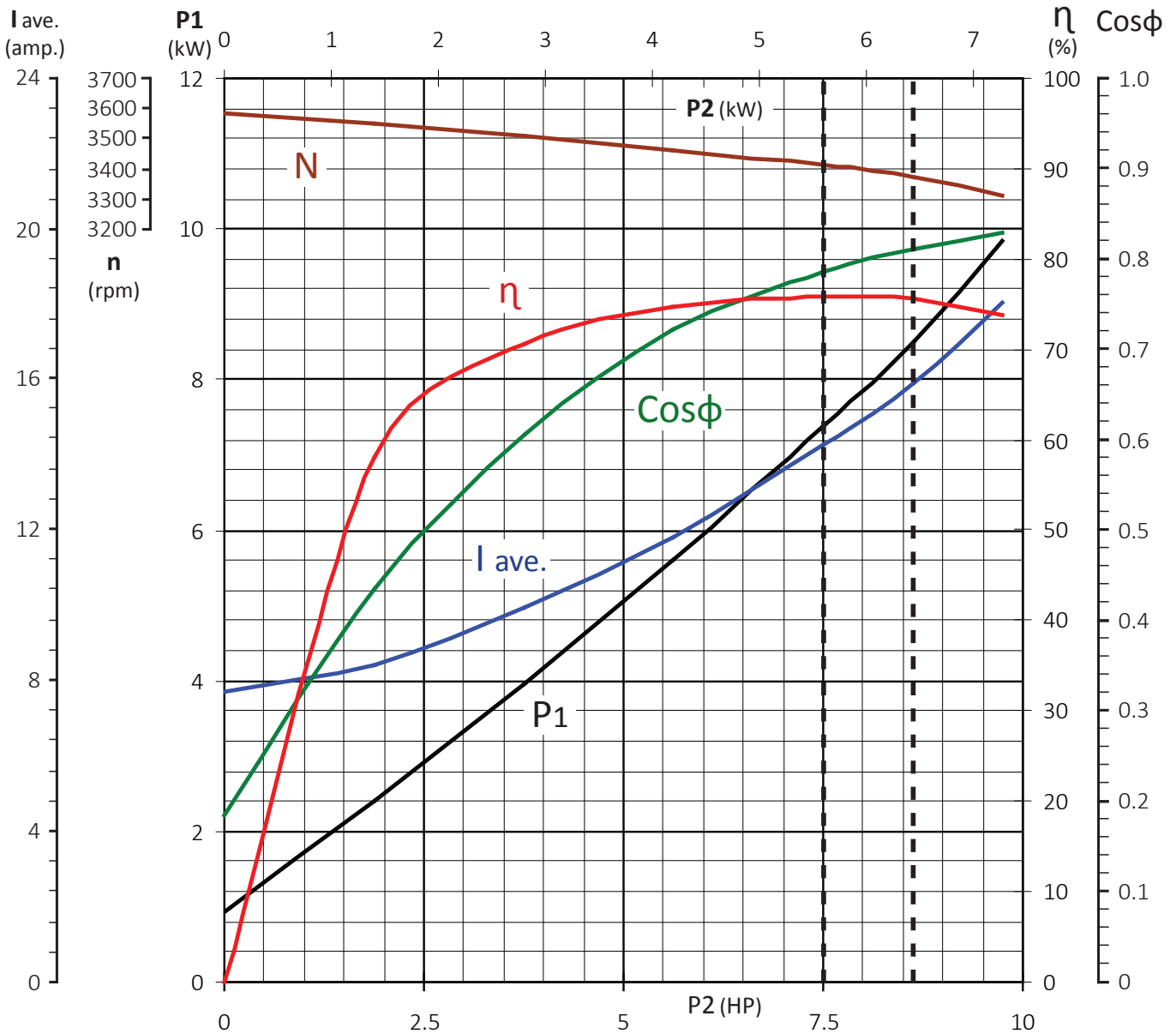

Load	Frequency Hz	Volt ave. V	I ave. A	P1 kW	P1 HP	RPM	Torque Nm	P2 kW	P2 HP	Efficiency %	Cos pi
0%	60.00	380.0	7.73	0.94	1.26	3586.1	0.00	0.00	0.00	0.00%	0.184
25%	60.00	380.0	8.42	2.41	3.23	3548.4	3.76	1.40	1.88	57.99%	0.435
50%	60.00	380.0	9.93	3.96	5.31	3506.6	7.62	2.80	3.75	70.65%	0.606
75%	60.00	380.0	11.81	5.61	7.52	3461.9	11.57	4.20	5.63	74.80%	0.722
100%	60.00	380.0	14.26	7.38	9.89	3409.6	15.67	5.60	7.50	75.82%	0.786
115%	60.00	380.0	15.92	8.50	11.39	3368.7	18.24	6.43	8.63	75.70%	0.811
130%	60.00	380.0	18.06	9.85	13.21	3310.5	20.98	7.27	9.75	73.83%	0.829

Motor Performance Curve

tolerances according to NEMA standard and IEC 60034-1

10 HP | **7.5** kW | **380** Volt | **60** Hertz | **2** Pole

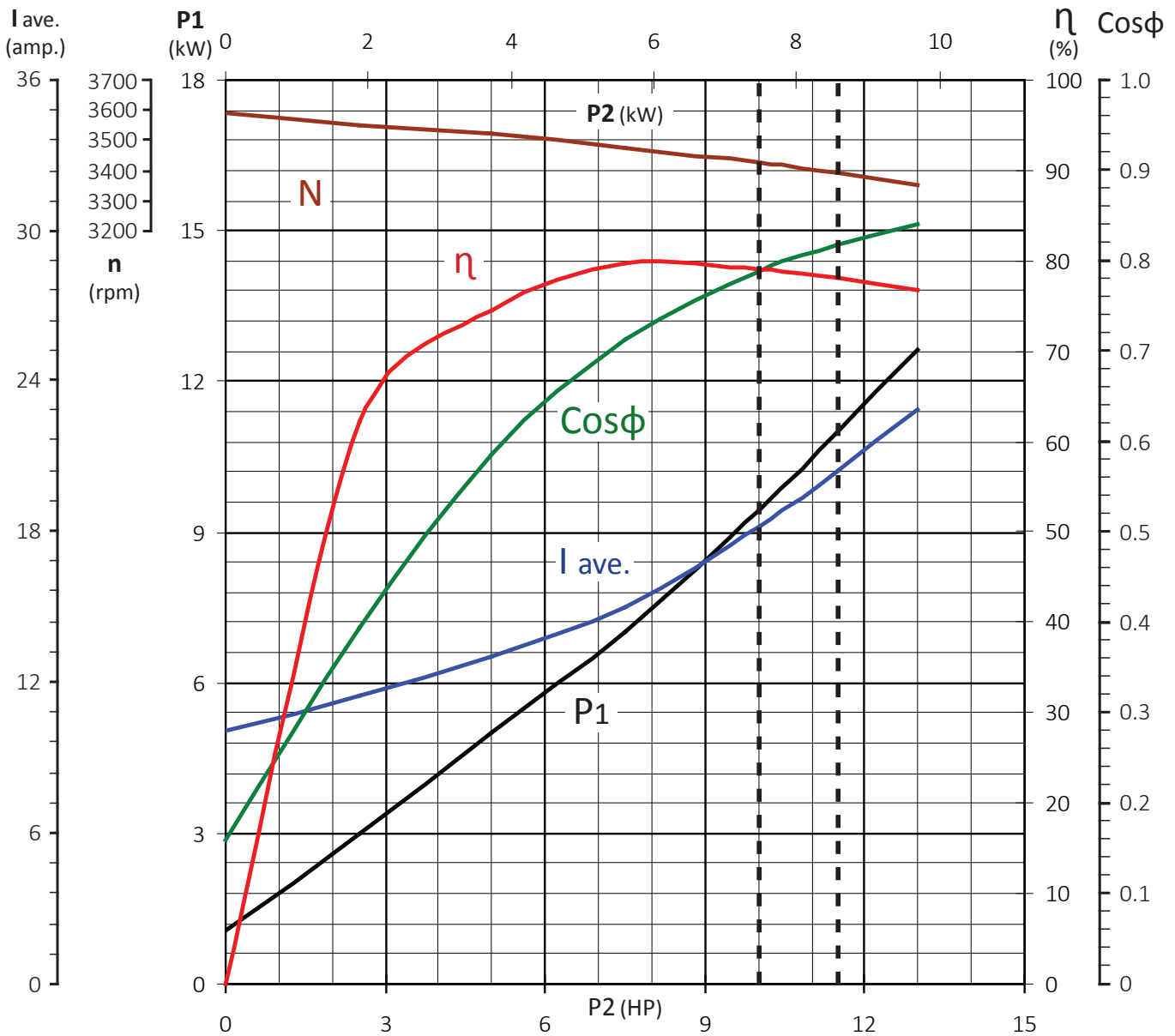

6" 60 HZ SERIES

Load	Frequency Hz	Volt ave. V	I ave. A	P1 kW	P1 HP	RPM	Torque Nm	P2 kW	P2 HP	Efficiency %	Cos pi
0%	60.00	380.0	10.10	1.06	1.42	3589.7	0.00	0.00	0.00	0.00%	0.159
25%	60.00	380.0	11.52	2.99	4.01	3552.3	5.01	1.87	2.50	62.27%	0.395
50%	60.00	380.0	13.00	5.00	6.71	3521.7	10.11	3.73	5.00	74.53%	0.585
75%	60.00	380.0	14.99	7.02	9.41	3473.2	15.38	5.60	7.50	79.67%	0.712
100%	60.00	380.0	18.18	9.44	12.66	3429.8	20.77	7.46	10.00	79.01%	0.789
115%	60.00	380.0	20.42	10.99	14.74	3392.4	24.15	8.58	11.50	78.04%	0.818
130%	60.00	380.0	22.85	12.64	16.94	3354.8	27.60	9.70	13.00	76.75%	0.840

Motor Performance Curve

tolerances according to NEMA standard and IEC 60034-1

15 HP | **11.2** kW | **380** Volt | **60** Hertz | **2** Pole

6" 60 HZ SERIES

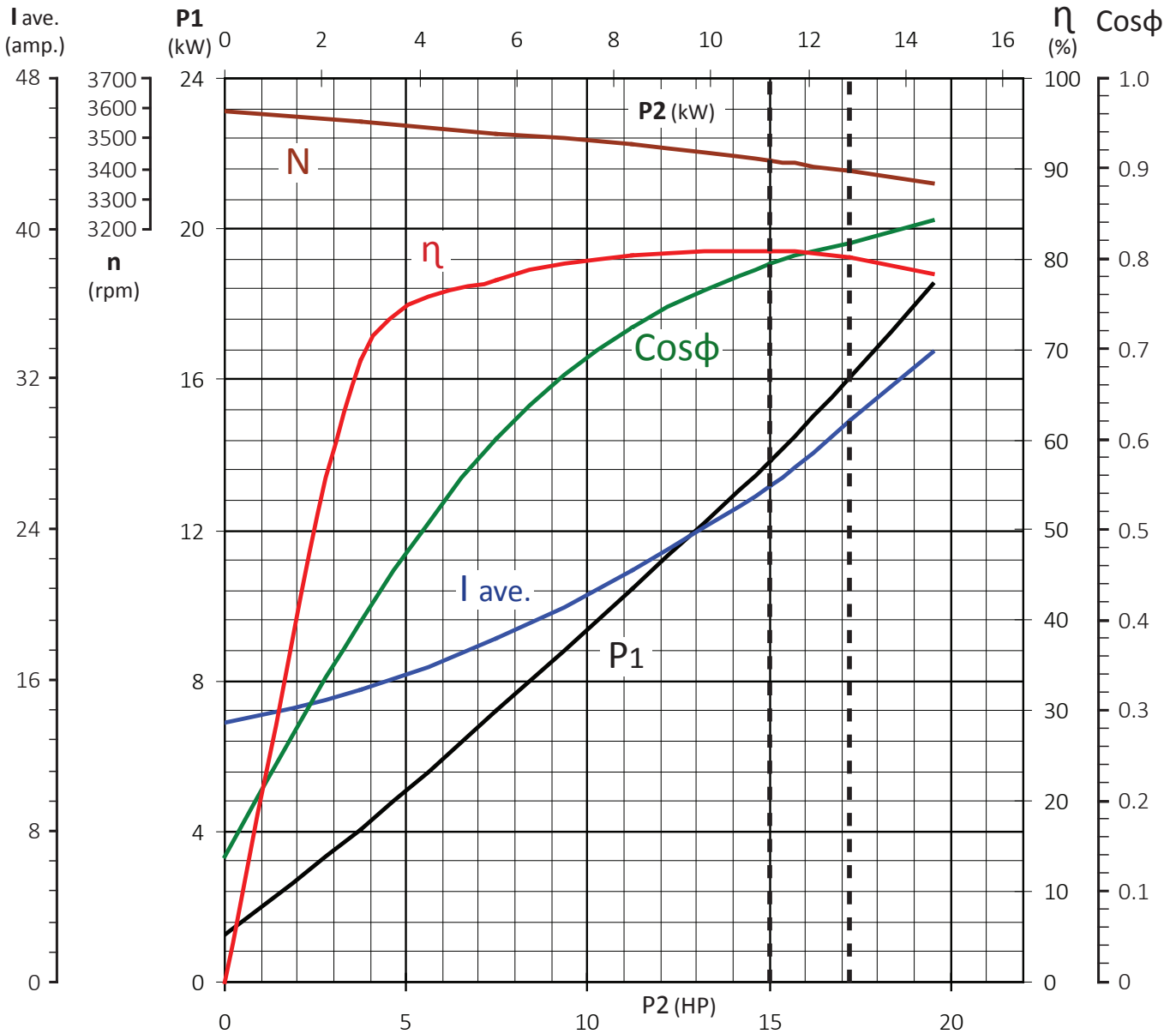

Load	Frequency Hz	Volt ave. V	I ave. A	P1 kW	P1 HP	RPM	Torque Nm	P2 kW	P2 HP	Efficiency %	Cos pi
0%	60.00	380.0	13.75	1.25	1.67	3591.4	0.00	0.00	0.00	0.00%	0.138
25%	60.00	380.0	15.50	4.07	5.46	3557.4	7.51	2.80	3.75	68.73%	0.399
50%	60.00	380.0	18.21	7.20	9.65	3517.9	15.19	5.60	7.50	77.69%	0.601
75%	60.00	380.0	21.86	10.43	13.98	3478.2	23.04	8.39	11.25	80.47%	0.725
100%	60.00	380.0	26.39	13.83	18.53	3429.8	31.16	11.19	15.00	80.93%	0.796
115%	60.00	380.0	29.85	16.07	21.54	3390.6	36.24	12.87	17.25	80.08%	0.818
130%	60.00	380.0	33.46	18.54	24.86	3353.2	41.43	14.55	19.50	78.45%	0.842

Motor Performance Curve

tolerances according to NEMA standard and IEC 60034-1

20 HP | **14.9** kW | **380** Volt | **60** Hertz | **2** Pole

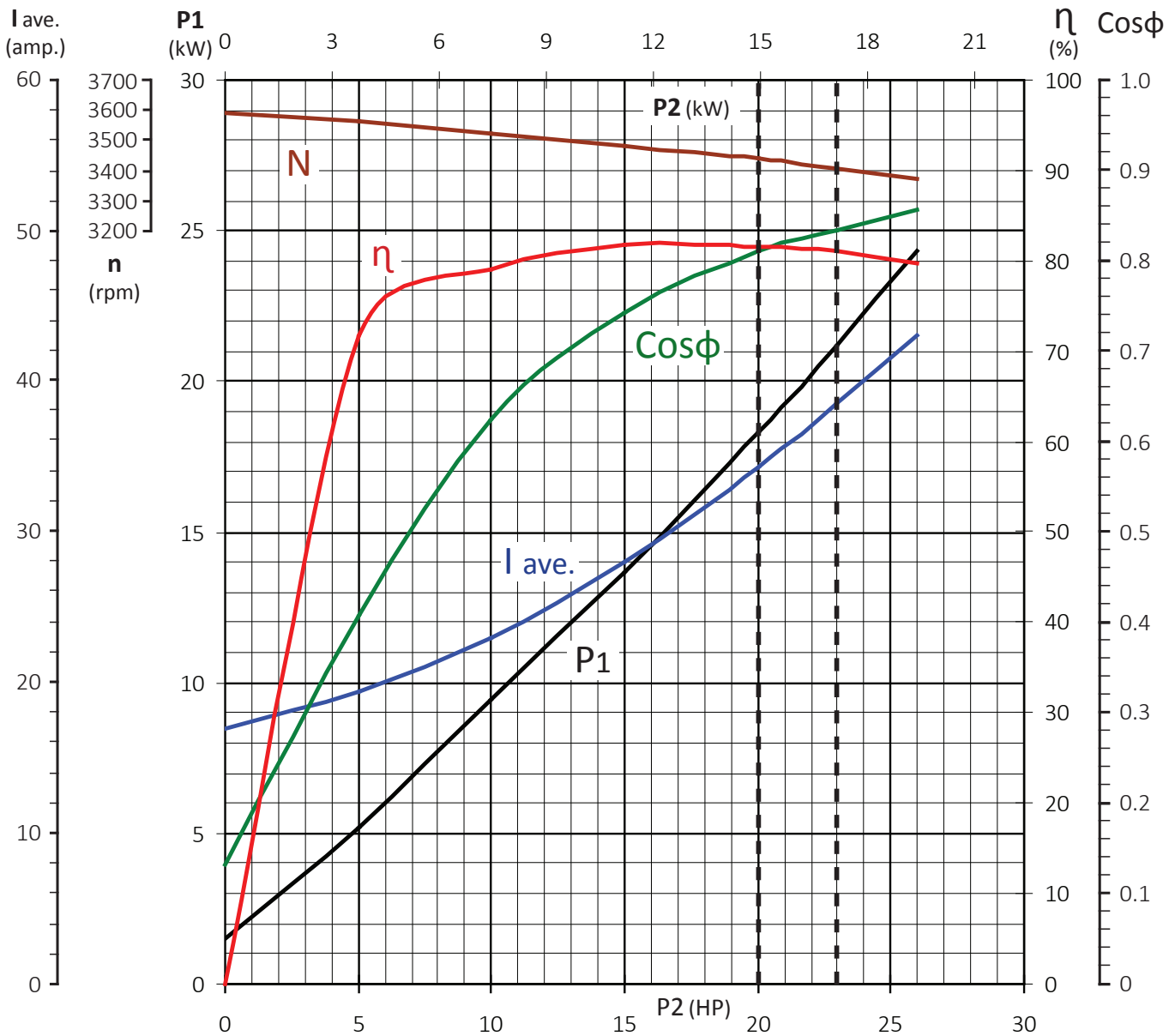

6" 60 HZ SERIES

Load	Frequency Hz	Volt ave. V	I ave. A	P1 kW	P1 HP	RPM	Torque Nm	P2 kW	P2 HP	Efficiency %	Cos pi
0%	60.00	380.0	16.92	1.47	1.97	3592.8	0.00	0.00	0.00	0.00%	0.132
25%	60.00	380.0	19.43	5.21	6.98	3566.3	9.99	3.73	5.00	71.65%	0.407
50%	60.00	380.0	22.92	9.43	12.64	3524.7	20.21	7.46	10.00	79.12%	0.625
75%	60.00	380.0	28.00	13.67	18.33	3483.9	30.67	11.19	15.00	81.83%	0.742
100%	60.00	380.0	34.33	18.30	24.53	3439.9	41.42	14.92	20.00	81.52%	0.810
115%	60.00	380.0	38.56	21.17	28.37	3408.7	48.07	17.16	23.00	81.07%	0.834
130%	60.00	380.0	43.12	24.32	32.60	3375.1	54.88	19.40	26.00	79.76%	0.857

Motor Performance Curve

tolerances according to NEMA standard and IEC 60034-1

25 HP | **18.6** kW | **380** Volt | **60** Hertz | **2** Pole

6" 60 HZ SERIES

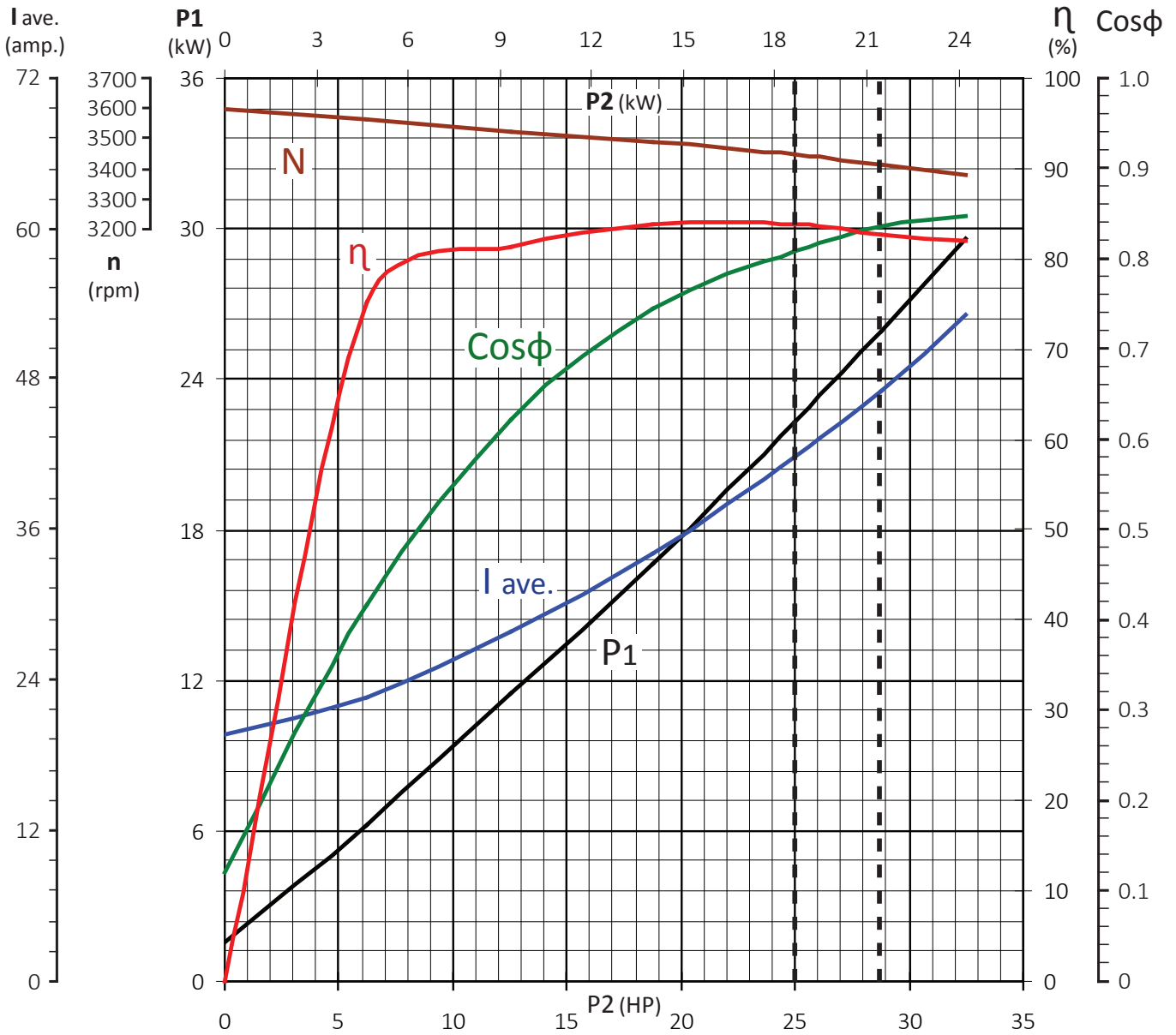

Load	Frequency Hz	Volt ave. V	I ave. A	P1 kW	P1 HP	RPM	Torque Nm	P2 kW	P2 HP	Efficiency %	Cos pi
0%	60.00	380.0	19.76	1.56	2.09	3594.5	0.00	0.00	0.00	0.00%	0.120
25%	60.00	380.0	22.63	6.21	8.33	3561.9	12.50	4.66	6.25	75.07%	0.417
50%	60.00	380.0	27.93	11.45	15.35	3523.1	25.28	9.33	12.50	81.41%	0.623
75%	60.00	380.0	34.04	16.67	22.35	3485.9	38.32	13.99	18.75	83.91%	0.744
100%	60.00	380.0	41.82	22.27	29.85	3444.8	51.70	18.65	25.00	83.76%	0.809
115%	60.00	380.0	47.04	25.91	34.73	3414.5	59.98	21.45	28.75	82.77%	0.837
130%	60.00	380.0	53.07	29.59	39.66	3380.4	68.49	24.25	32.50	81.95%	0.847

Motor Performance Curve

tolerances according to NEMA standard and IEC 60034-1

30 HP | **22.4** kW | **380** Volt | **60** Hertz | **2** Pole

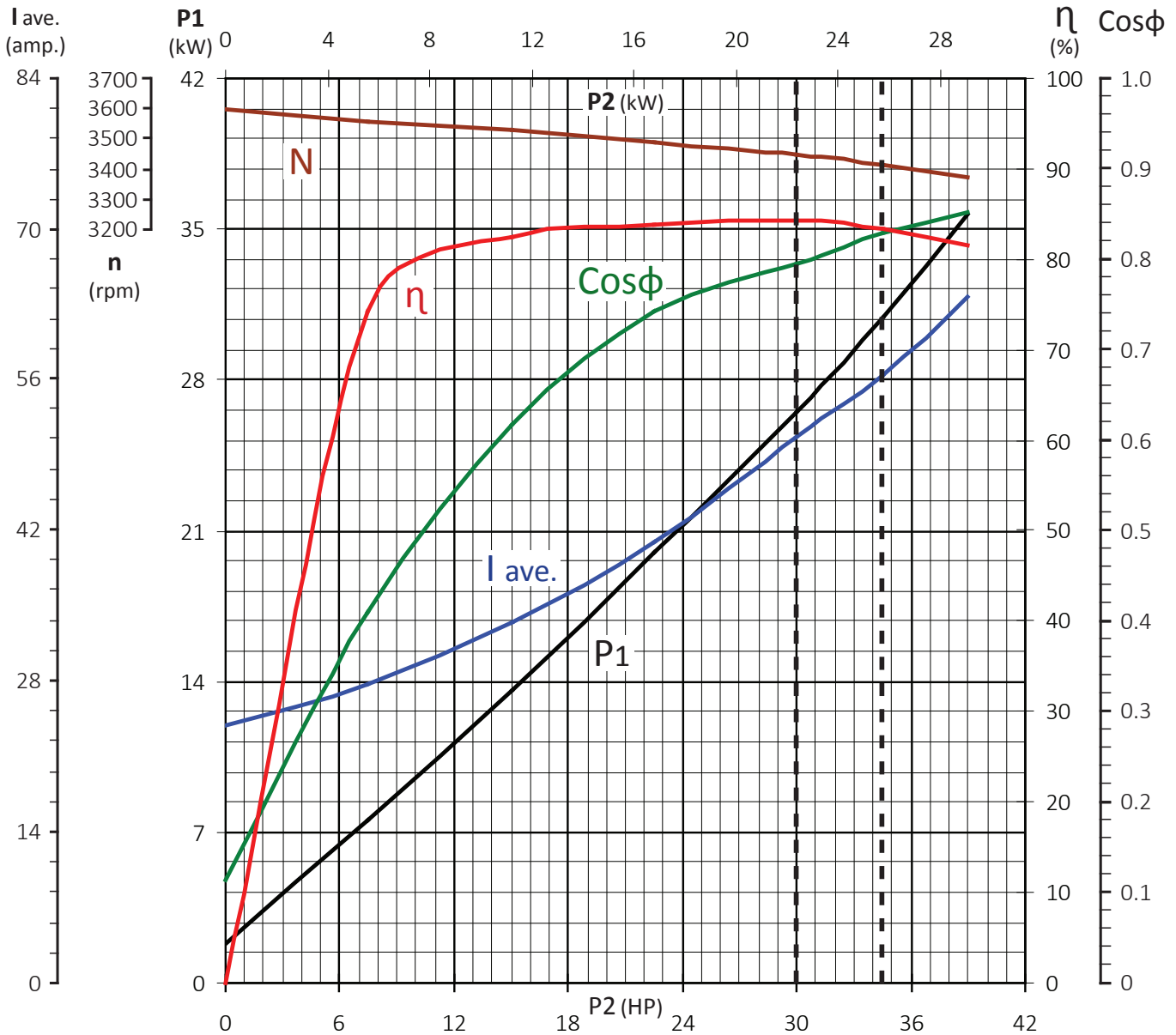

6" 60 HZ SERIES

Load	Frequency Hz	Volt ave. V	I ave. A	P1 kW	P1 HP	RPM	Torque Nm	P2 kW	P2 HP	Efficiency %	Cos pi
0%	60.00	380.0	23.97	1.78	2.39	3596.7	0.00	0.00	0.00	0.00%	0.113
25%	60.00	380.0	27.83	7.53	10.09	3558.7	15.01	5.60	7.50	74.33%	0.411
50%	60.00	380.0	33.39	13.56	18.18	3526.6	30.30	11.19	15.00	82.52%	0.617
75%	60.00	380.0	40.99	20.02	26.83	3485.3	45.99	16.79	22.50	83.86%	0.742
100%	60.00	380.0	50.66	26.54	35.58	3444.6	62.04	22.38	30.00	84.32%	0.796
115%	60.00	380.0	56.54	30.89	41.40	3409.7	72.08	25.74	34.50	83.33%	0.830
130%	60.00	380.0	63.73	35.69	47.85	3372.5	82.38	29.09	39.00	81.51%	0.851

Motor Performance Curve

tolerances according to NEMA standard and IEC 60034-1

40 HP | **29.8** kW | **380** Volt | **60** Hertz | **2** Pole

6" 60 HZ SERIES

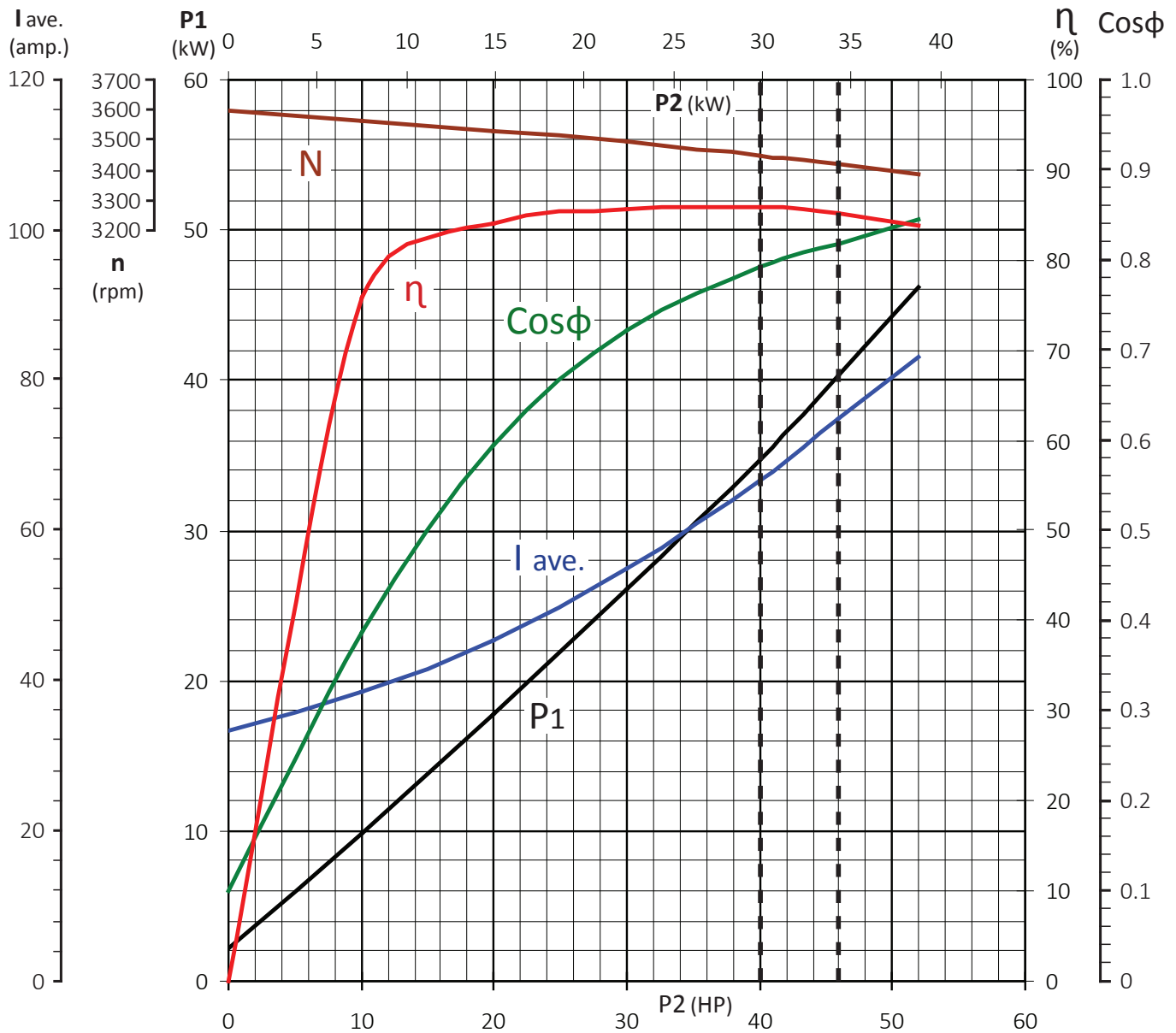

Load	Frequency Hz	Volt ave. V	I ave. A	P1 kW	P1 HP	RPM	Torque Nm	P2 kW	P2 HP	Efficiency %	Cos pi
0%	60.00	380.0	33.35	2.20	2.94	3596.4	0.00	0.00	0.00	0.00%	0.100
25%	60.00	380.0	38.49	9.83	13.18	3564.2	19.99	7.46	10.00	75.90%	0.388
50%	60.00	380.0	45.39	17.77	23.82	3528.2	40.38	14.92	20.00	83.95%	0.595
75%	60.00	380.0	54.99	26.10	34.98	3492.1	61.20	22.38	30.00	85.76%	0.721
100%	60.00	380.0	66.59	34.71	46.53	3450.3	82.59	29.84	40.00	85.97%	0.792
115%	60.00	380.0	74.81	40.28	53.99	3416.6	95.91	34.32	46.00	85.20%	0.818
130%	60.00	380.0	83.23	46.24	61.98	3382.8	109.50	38.79	52.00	83.90%	0.844

Motor Performance Curve

tolerances according to NEMA standard and IEC 60034-1

50 HP | **37.3** kW | **380** Volt | **60** Hertz | **2** Pole

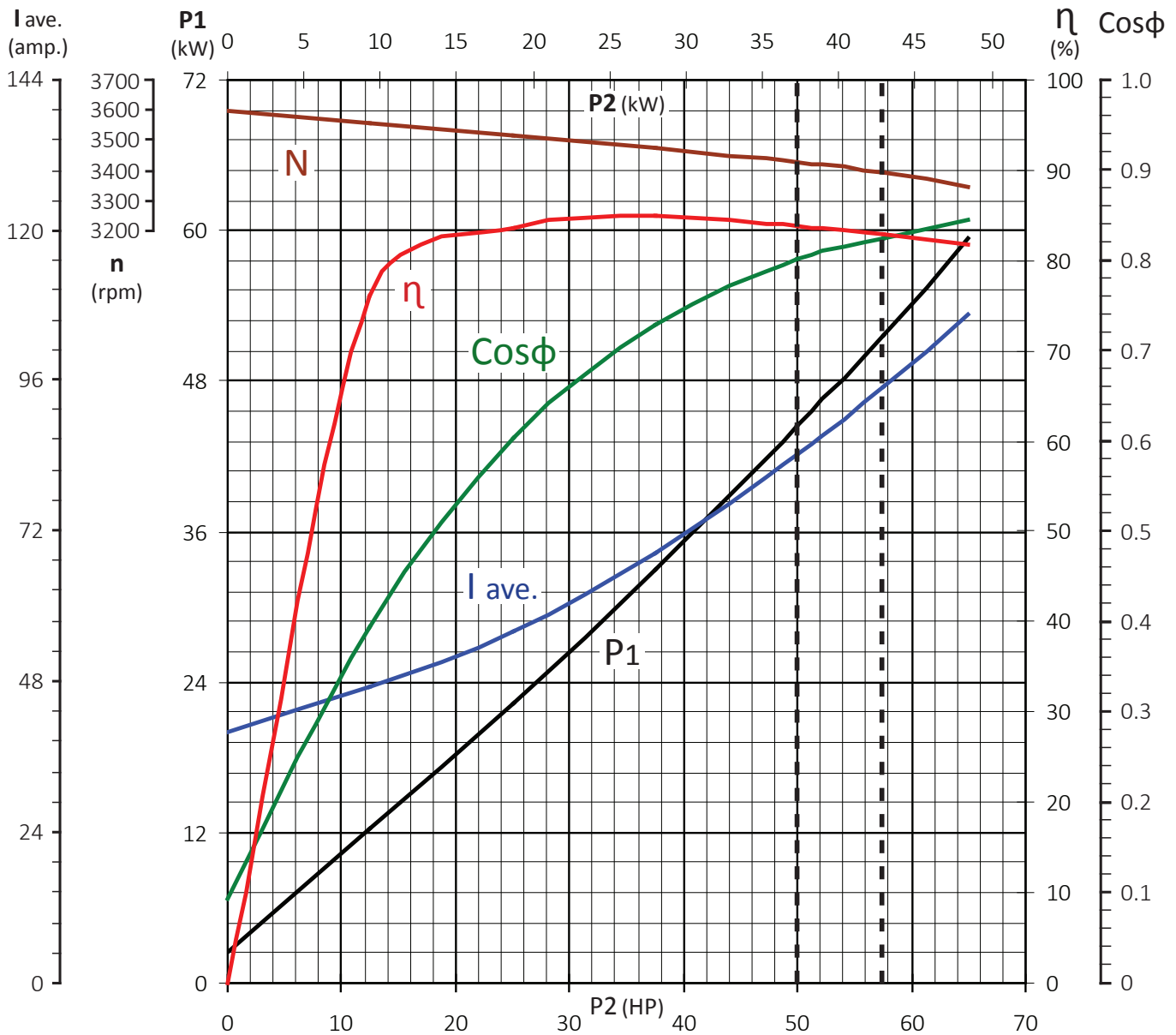

6" 60 HZ SERIES

Load	Frequency Hz	Volt ave. V	I ave. A	P1 kW	P1 HP	RPM	Torque Nm	P2 kW	P2 HP	Efficiency %	Cos pi
0%	60.00	380.0	39.98	2.45	3.28	3595.6	0.00	0.00	0.00	0.00%	0.093
25%	60.00	380.0	47.09	12.24	16.41	3556.2	25.04	9.33	12.50	76.18%	0.395
50%	60.00	380.0	56.18	22.30	29.89	3518.9	50.61	18.65	25.00	83.64%	0.603
75%	60.00	380.0	68.67	32.95	44.17	3474.3	76.89	27.98	37.50	84.90%	0.729
100%	60.00	380.0	84.19	44.44	59.57	3424.9	104.00	37.30	50.00	83.94%	0.802
115%	60.00	380.0	95.24	51.71	69.32	3389.9	120.83	42.90	57.50	82.95%	0.825
130%	60.00	380.0	106.59	59.35	79.56	3343.5	138.49	48.49	65.00	81.70%	0.846

Motor Performance Curve

tolerances according to NEMA standard and IEC 60034-1

5.5 HP | **4.1** kW | **460** Volt | **60** Hertz | **2** Pole

6" 60 HZ SERIES

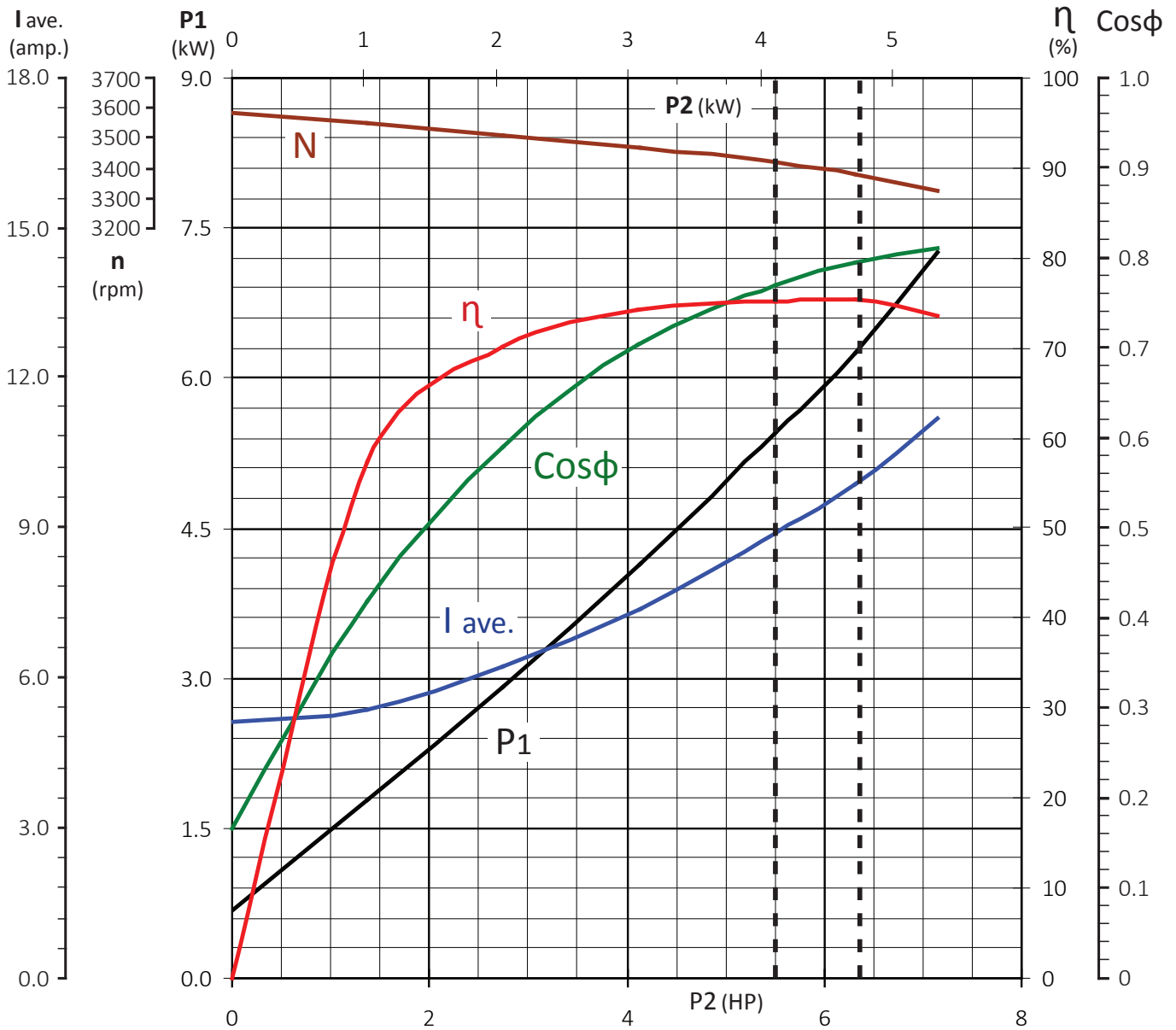

Load	Frequency Hz	Volt ave. V	I ave. A	P1 kW	P1 HP	RPM	Torque Nm	P2 kW	P2 HP	Efficiency %	Cos pi
0%	60.00	460.0	5.11	0.68	0.91	3587.1	0.00	0.00	0.00	0.00%	0.167
25%	60.00	460.0	5.37	1.79	2.40	3551.5	2.76	1.03	1.38	57.30%	0.418
50%	60.00	460.0	6.22	2.92	3.91	3511.9	5.58	2.05	2.75	70.26%	0.589
75%	60.00	460.0	7.37	4.14	5.55	3469.7	8.47	3.08	4.13	74.33%	0.705
100%	60.00	460.0	8.91	5.46	7.32	3420.2	11.46	4.10	5.50	75.15%	0.769
115%	60.00	460.0	9.90	6.26	8.39	3381.5	13.32	4.72	6.33	75.37%	0.794
130%	60.00	460.0	11.21	7.25	9.72	3326.1	15.31	5.33	7.15	73.57%	0.812

Motor Performance Curve

tolerances according to NEMA standard and IEC 60034-1

7.5 HP | **5.6** kW | **460** Volt | **60** Hertz | **2** Pole

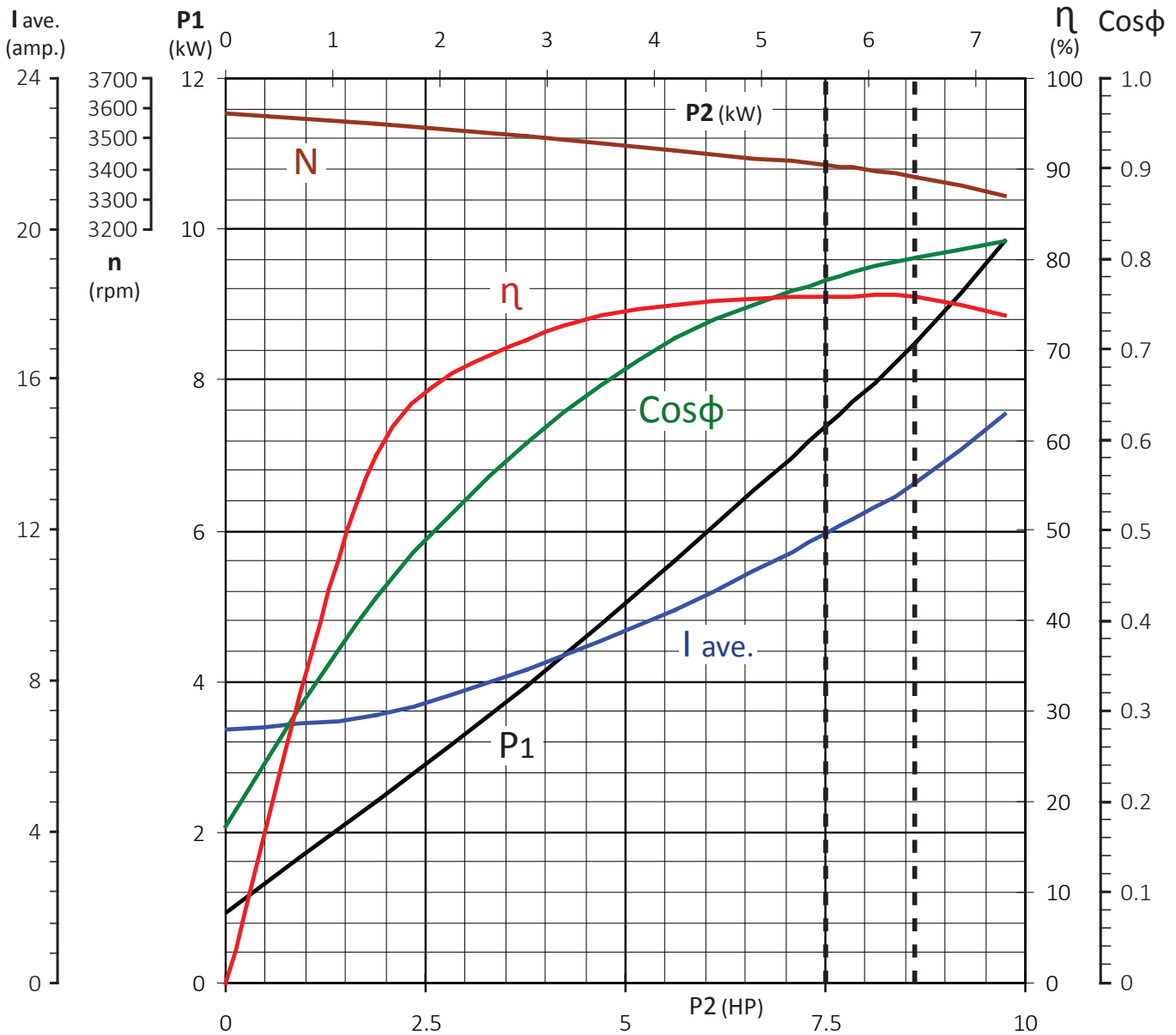

6" 60 HZ SERIES

Load	Frequency Hz	Volt ave. V	I ave. A	P1 kW	P1 HP	RPM	Torque Nm	P2 kW	P2 HP	Efficiency %	Cos pi
0%	60.00	460.0	6.71	0.93	1.25	3586.2	0.00	0.00	0.00	0.00%	0.174
25%	60.00	460.0	7.09	2.40	3.22	3548.6	3.76	1.40	1.88	58.28%	0.425
50%	60.00	460.0	8.30	3.94	5.28	3506.7	7.62	2.80	3.75	71.00%	0.596
75%	60.00	460.0	9.87	5.60	7.51	3462.1	11.57	4.20	5.63	74.93%	0.712
100%	60.00	460.0	11.92	7.37	9.88	3409.8	15.67	5.60	7.50	75.92%	0.776
115%	60.00	460.0	13.30	8.49	11.38	3368.9	18.24	6.43	8.63	75.79%	0.801
130%	60.00	460.0	15.08	9.84	13.19	3310.7	20.98	7.27	9.75	73.92%	0.819

Motor Performance Curve

tolerances according to NEMA standard and IEC 60034-1

10 HP | **7.5** kW | **460** Volt | **60** Hertz | **2** Pole

6" 60 HZ SERIES

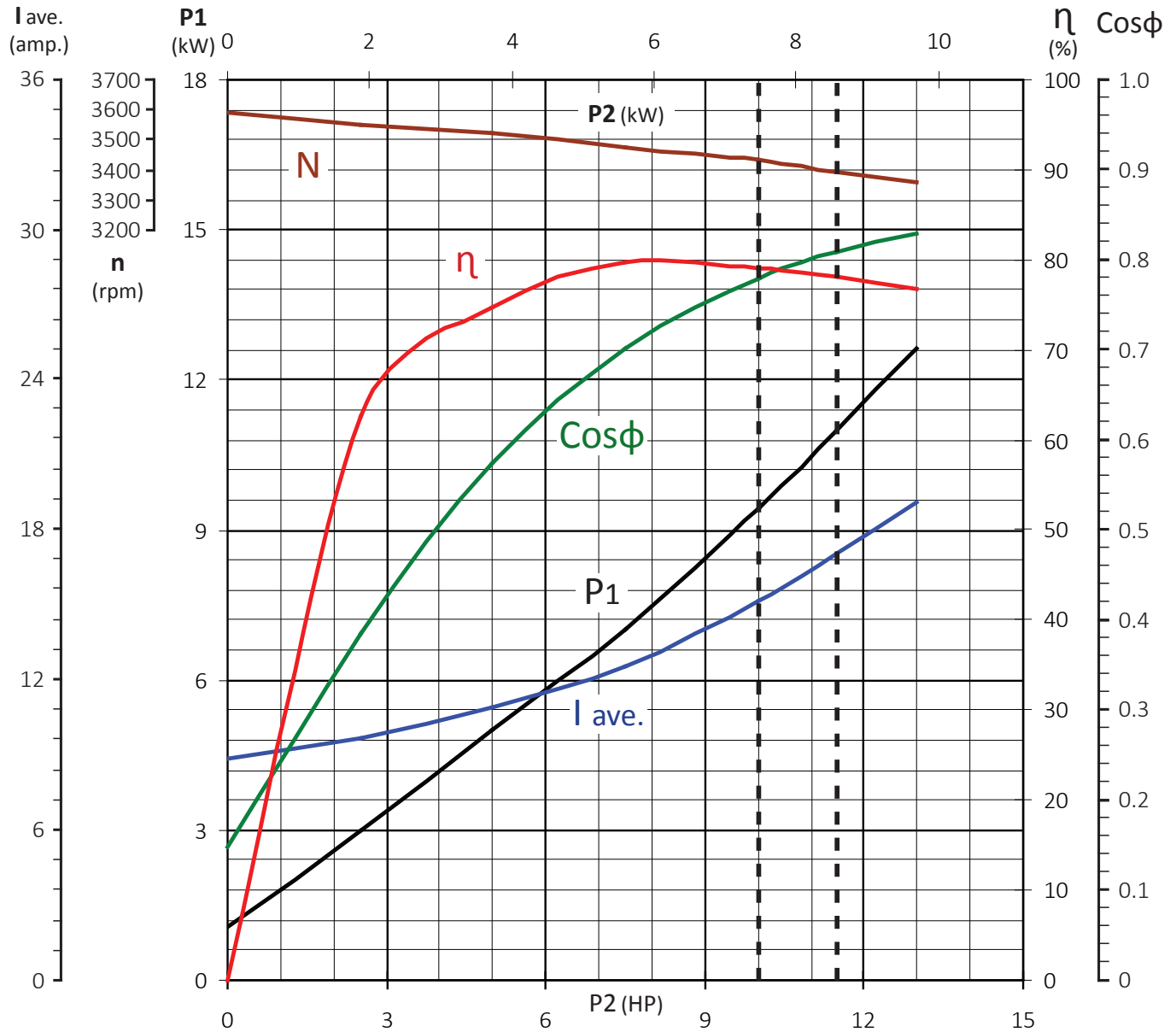

Load	Frequency Hz	Volt ave. V	I ave. A	P1 kW	P1 HP	RPM	Torque Nm	P2 kW	P2 HP	Efficiency %	Cos pi
0%	60.00	460.0	8.84	1.05	1.41	3589.9	0.00	0.00	0.00	0.00%	0.149
25%	60.00	460.0	9.72	2.98	3.99	3552.5	5.01	1.87	2.50	62.58%	0.385
50%	60.00	460.0	10.89	4.99	6.69	3522.0	10.11	3.73	5.00	74.75%	0.575
75%	60.00	460.0	12.53	7.01	9.40	3473.5	15.38	5.60	7.50	79.81%	0.702
100%	60.00	460.0	15.19	9.43	12.64	3430.2	20.77	7.46	10.00	79.11%	0.779
115%	60.00	460.0	17.06	10.98	14.72	3392.8	24.15	8.58	11.50	78.13%	0.808
130%	60.00	460.0	19.08	12.62	16.92	3355.3	27.60	9.70	13.00	76.85%	0.830

Motor Performance Curve

tolerances according to NEMA standard and IEC 60034-1

15 HP | **11.2** kW | **460** Volt | **60** Hertz | **2** Pole

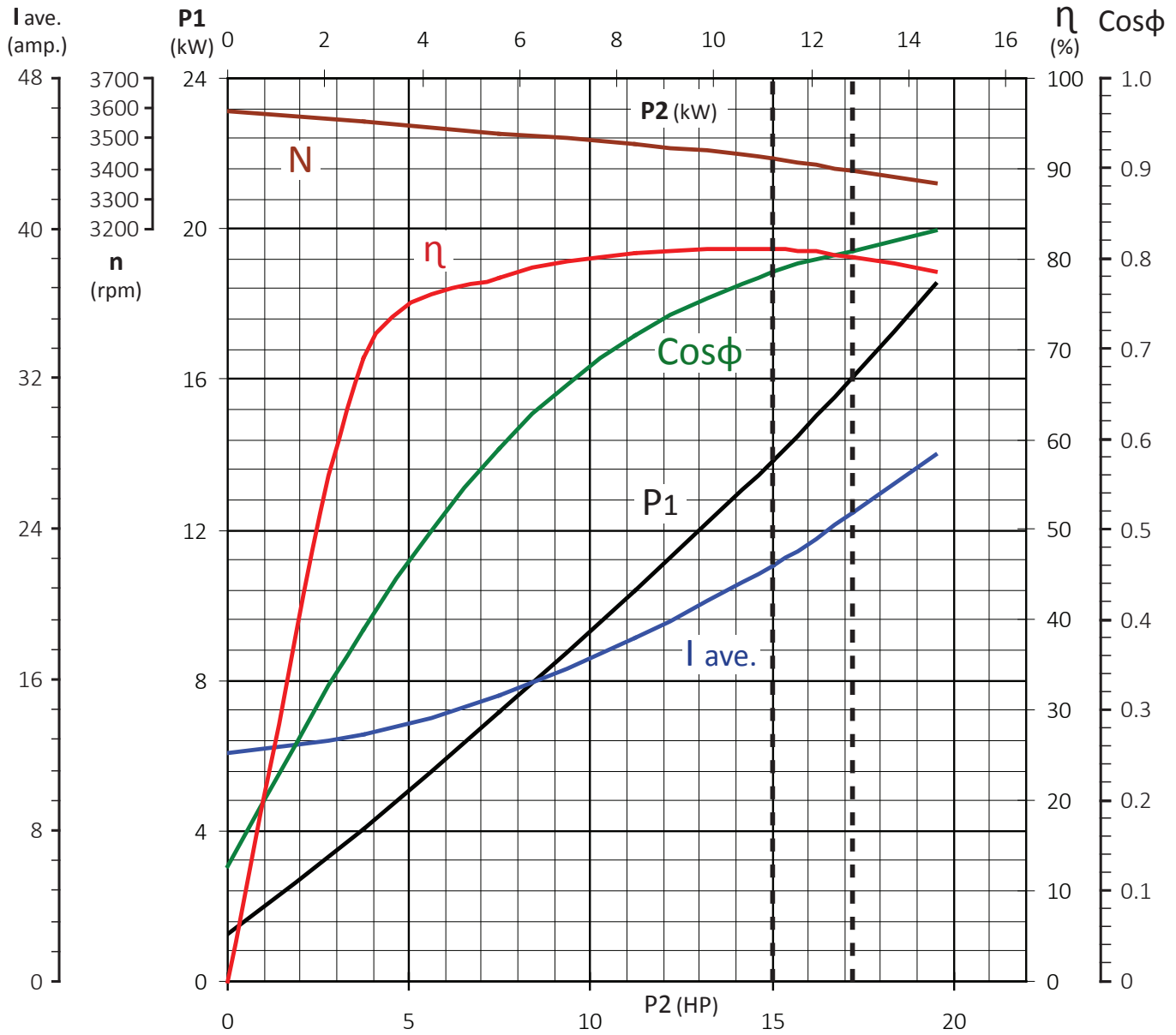

6" 60 HZ SERIES

Load	Frequency Hz	Volt ave. V	I ave. A	P1 kW	P1 HP	RPM	Torque Nm	P2 kW	P2 HP	Efficiency %	Cos pi
0%	60.00	460.0	12.16	1.24	1.66	3591.7	0.00	0.00	0.00	0.00%	0.128
25%	60.00	460.0	13.07	4.05	5.43	3557.7	7.51	2.80	3.75	69.07%	0.389
50%	60.00	460.0	15.25	7.18	9.62	3518.3	15.19	5.60	7.50	77.92%	0.591
75%	60.00	460.0	18.27	10.41	13.95	3478.7	23.04	8.39	11.25	80.62%	0.715
100%	60.00	460.0	22.05	13.81	18.51	3430.3	31.15	11.19	15.00	81.03%	0.786
115%	60.00	460.0	24.93	16.05	21.51	3391.2	36.24	12.87	17.25	80.18%	0.808
130%	60.00	460.0	27.94	18.52	24.83	3353.8	41.42	14.55	19.50	78.55%	0.832

Motor Performance Curve

tolerances according to NEMA standard and IEC 60034-1

20 HP | **14.9** kW | **460** Volt | **60** Hertz | **2** Pole

6" 60 HZ SERIES

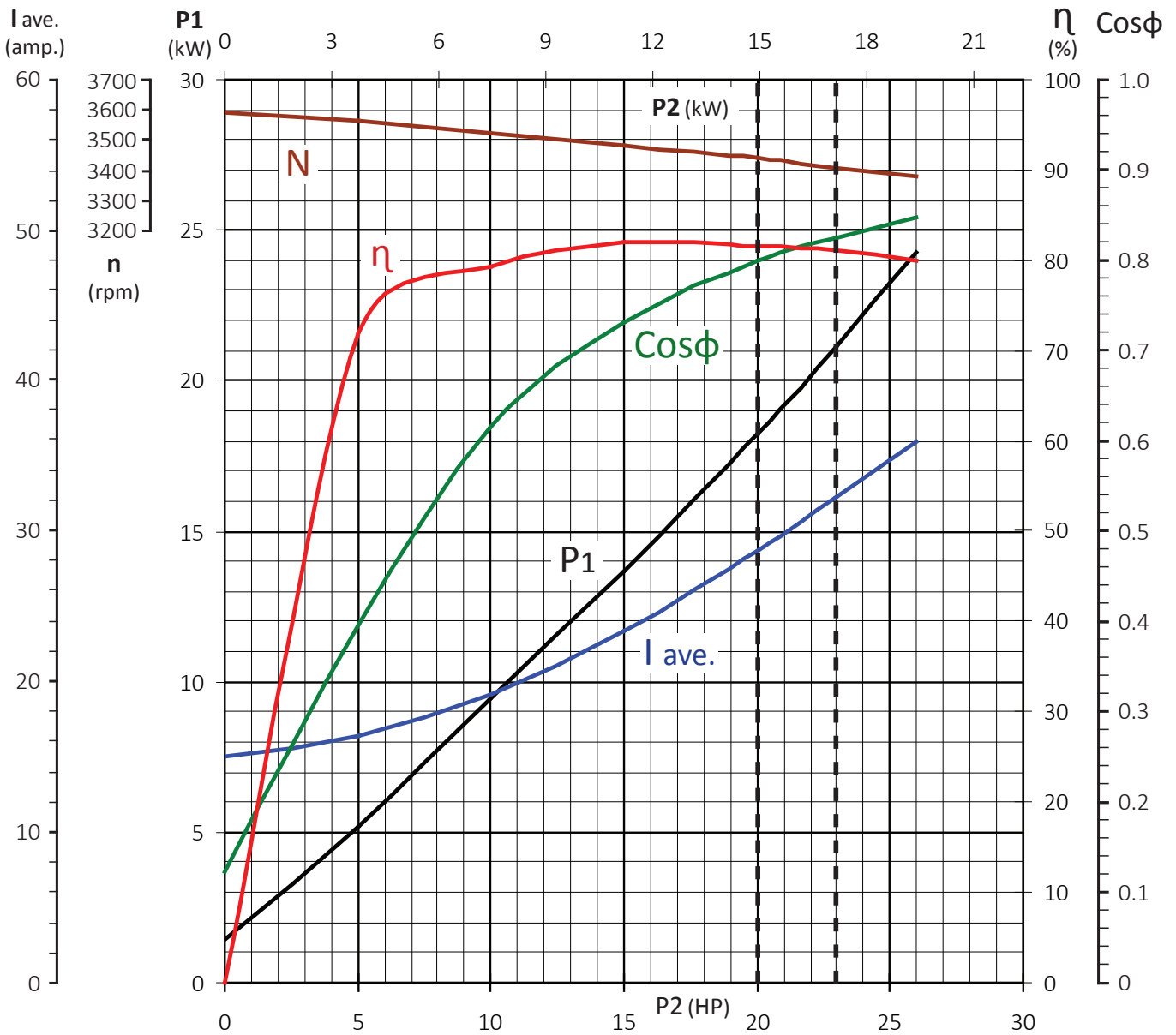

Load	Frequency Hz	Volt ave. V	I ave. A	P1 kW	P1 HP	RPM	Torque Nm	P2 kW	P2 HP	Efficiency %	Cos pi
0%	60.00	460.0	15.02	1.46	1.96	3593.0	0.00	0.00	0.00	0.00%	0.122
25%	60.00	460.0	16.38	5.18	6.94	3566.6	9.99	3.73	5.00	72.01%	0.397
50%	60.00	460.0	19.18	9.40	12.60	3525.1	20.21	7.46	10.00	79.36%	0.615
75%	60.00	460.0	23.41	13.65	18.30	3484.3	30.67	11.19	15.00	81.98%	0.732
100%	60.00	460.0	28.68	18.28	24.50	3440.4	41.41	14.92	20.00	81.62%	0.800
115%	60.00	460.0	32.20	21.14	28.34	3409.2	48.06	17.16	23.00	81.16%	0.824
130%	60.00	460.0	35.99	24.29	32.56	3375.6	54.87	19.40	26.00	79.85%	0.847

Motor Performance Curve

tolerances according to NEMA standard and IEC 60034-1

25 HP | **18.6** kW | **460** Volt | **60** Hertz | **2** Pole

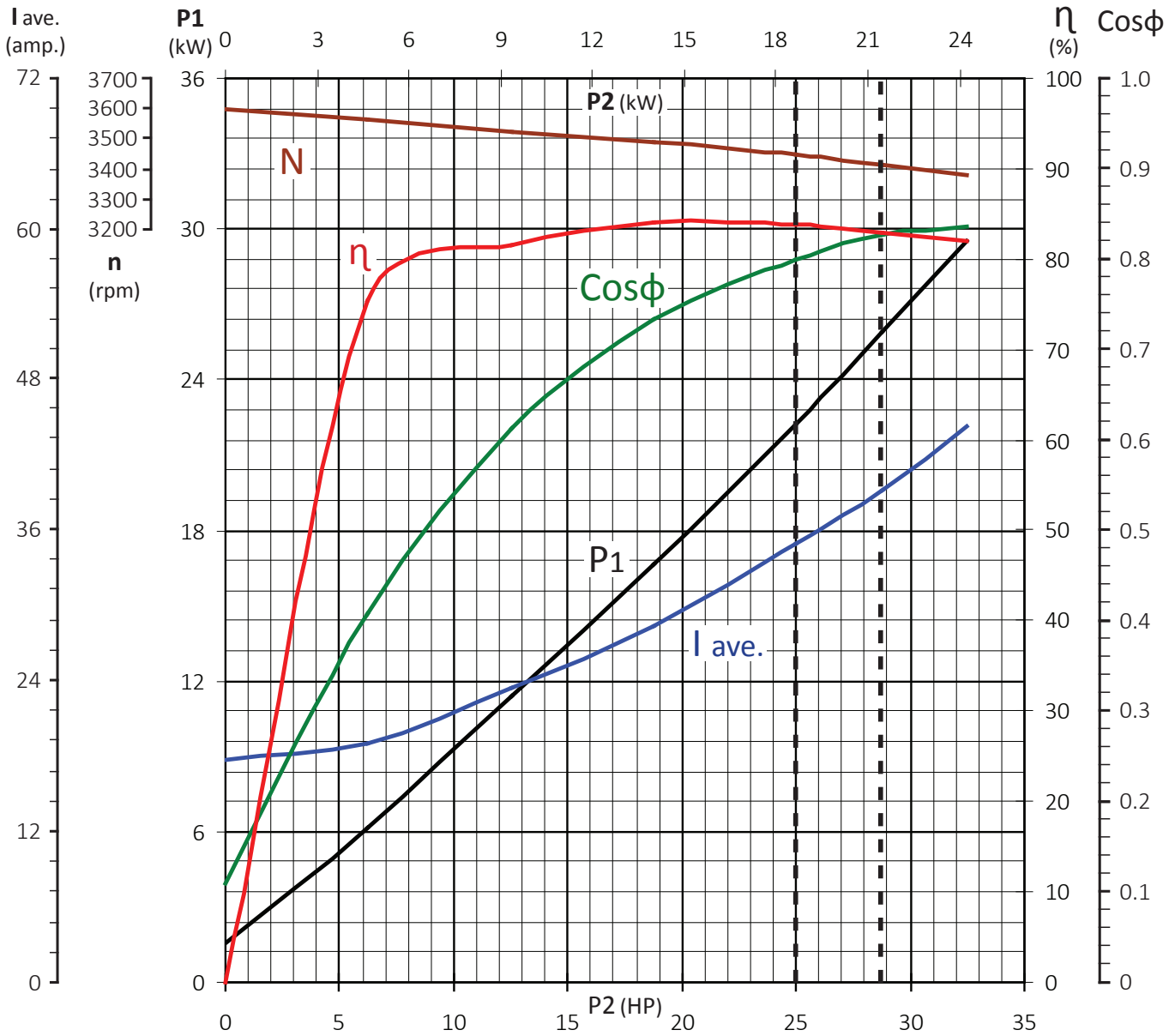

6" 60 HZ SERIES

Load	Frequency Hz	Volt ave. V	I ave. A	P1 kW	P1 HP	RPM	Torque Nm	P2 kW	P2 HP	Efficiency %	Cos pi
0%	60.00	460.0	17.69	1.55	2.08	3594.6	0.00	0.00	0.00	0.00%	0.110
25%	60.00	460.0	19.06	6.18	8.28	3562.1	12.50	4.66	6.25	75.44%	0.407
50%	60.00	460.0	23.38	11.42	15.31	3523.4	25.27	9.33	12.50	81.65%	0.613
75%	60.00	460.0	28.45	16.64	22.31	3486.2	38.31	13.99	18.75	84.06%	0.734
100%	60.00	460.0	34.94	22.24	29.81	3445.1	51.69	18.65	25.00	83.86%	0.799
115%	60.00	460.0	39.28	25.88	34.69	3414.9	59.98	21.45	28.75	82.87%	0.827
130%	60.00	460.0	44.31	29.55	39.61	3380.8	68.48	24.25	32.50	82.05%	0.837

Motor Performance Curve

tolerances according to NEMA standard and IEC 60034-1

30 HP | **22.4** kW | **460** Volt | **60** Hertz | **2** Pole

6" 60 HZ SERIES

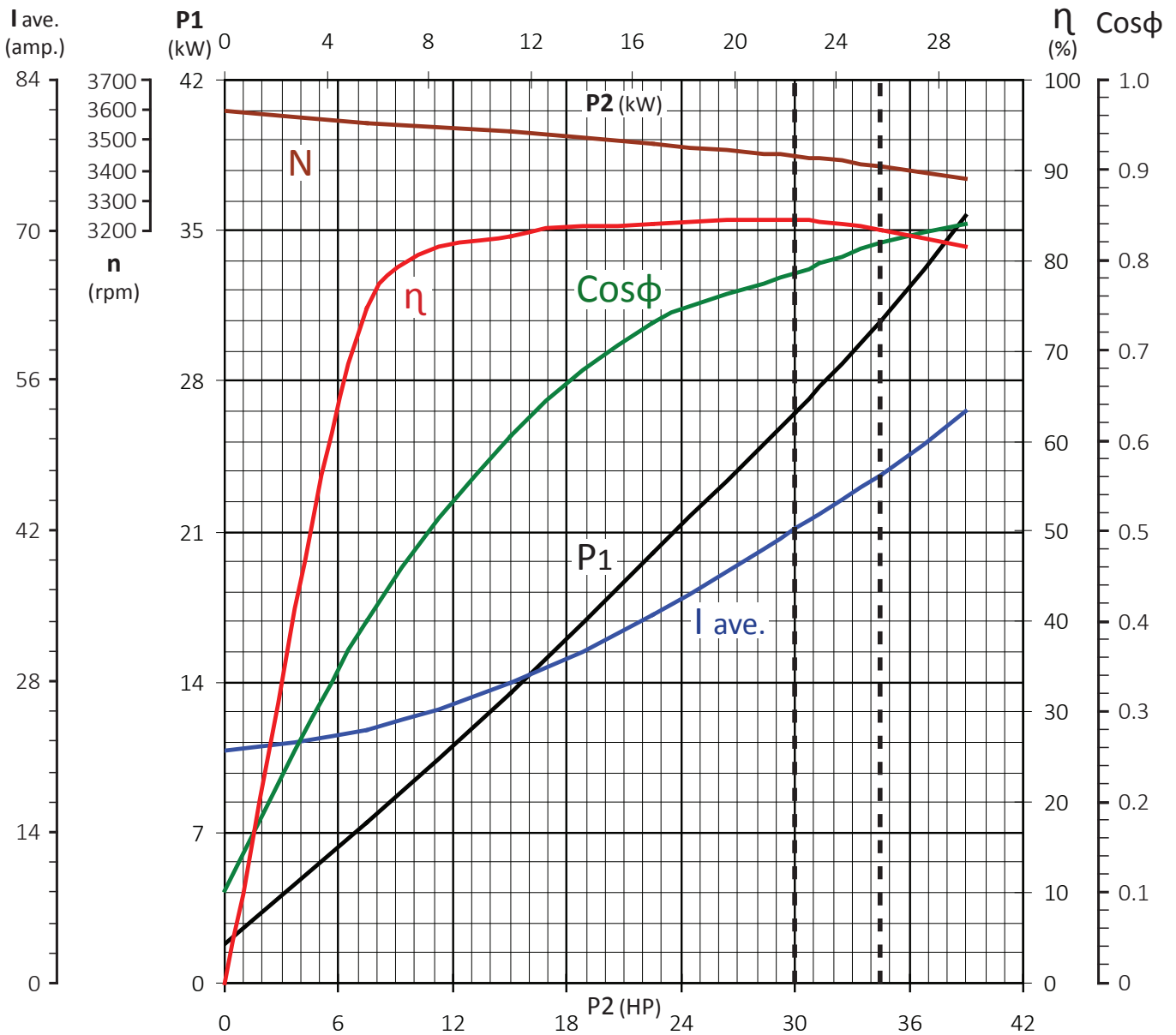

Load	Frequency Hz	Volt ave. V	I ave. A	P1 kW	P1 HP	RPM	Torque Nm	P2 kW	P2 HP	Efficiency %	Cos pi
0%	60.00	460.0	21.57	1.77	2.37	3596.8	0.00	0.00	0.00	0.00%	0.103
25%	60.00	460.0	23.44	7.49	10.04	3558.8	15.01	5.60	7.50	74.70%	0.401
50%	60.00	460.0	27.96	13.52	18.12	3526.7	30.30	11.19	15.00	82.77%	0.607
75%	60.00	460.0	34.26	19.98	26.78	3485.4	45.99	16.79	22.50	84.01%	0.732
100%	60.00	460.0	42.33	26.51	35.54	3444.8	62.04	22.38	30.00	84.42%	0.786
115%	60.00	460.0	47.22	30.85	41.35	3409.9	72.08	25.74	34.50	83.43%	0.820
130%	60.00	460.0	53.21	35.65	47.79	3372.6	82.38	29.09	39.00	81.61%	0.841

Motor Performance Curve

tolerances according to NEMA standard and IEC 60034-1

40 HP | **29.8** kW | **460** Volt | **60** Hertz | **2** Pole

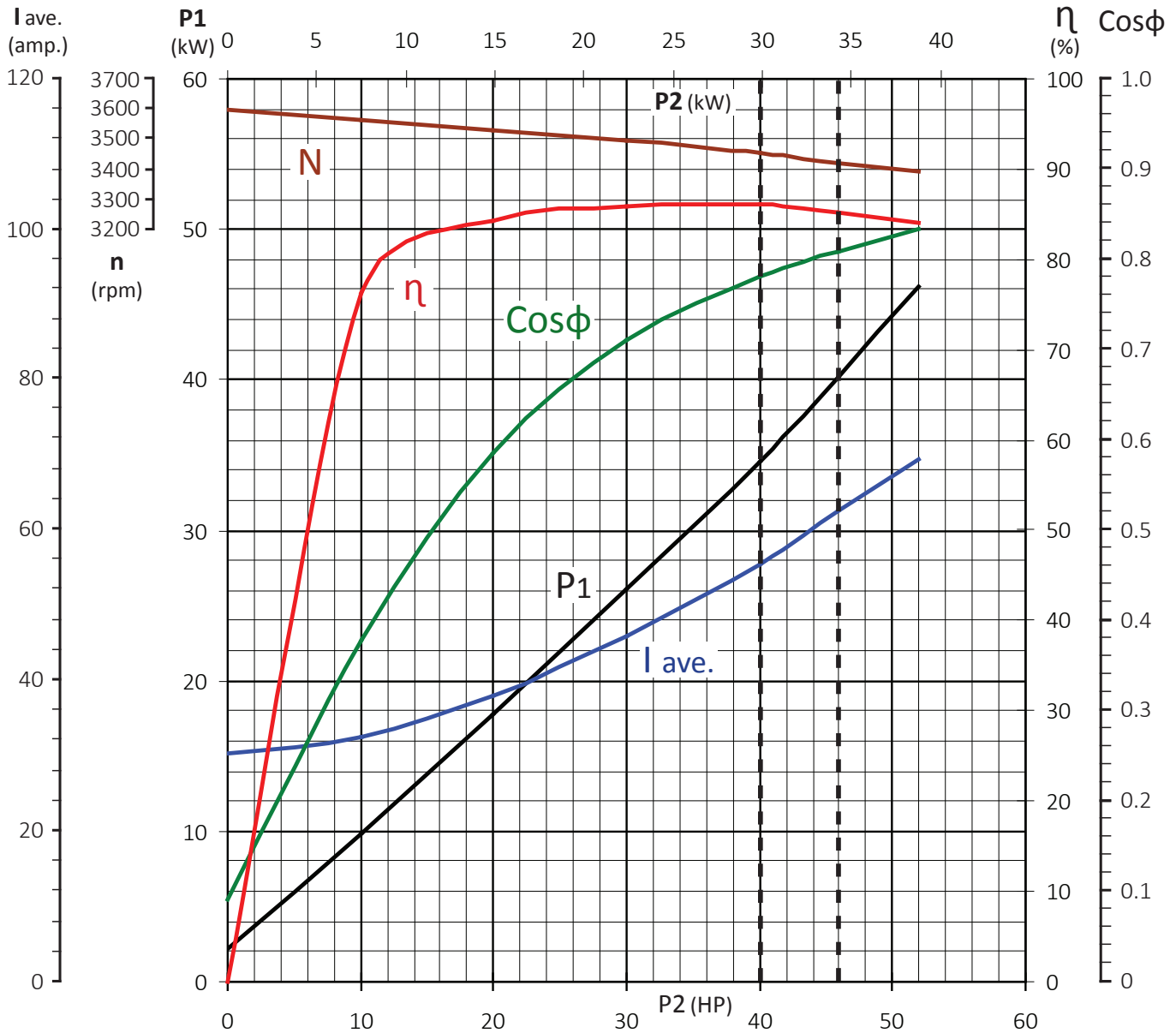

6" 60 HZ SERIES

Load	Frequency Hz	Volt ave. V	I ave. A	P1 kW	P1 HP	RPM	Torque Nm	P2 kW	P2 HP	Efficiency %	Cos pi
0%	60.00	460.0	30.40	2.18	2.92	3596.6	0.00	0.00	0.00	0.00%	0.090
25%	60.00	460.0	32.47	9.78	13.11	3565.4	19.98	7.46	10.00	76.28%	0.378
50%	60.00	460.0	38.02	17.72	23.75	3530.7	40.35	14.92	20.00	84.20%	0.585
75%	60.00	460.0	45.99	26.05	34.92	3495.8	61.13	22.38	30.00	85.91%	0.711
100%	60.00	460.0	55.60	34.64	46.43	3455.4	82.47	29.84	40.00	86.14%	0.782
115%	60.00	460.0	62.49	40.23	53.93	3422.8	95.74	34.32	46.00	85.30%	0.808
130%	60.00	460.0	69.50	46.18	61.90	3390.2	109.27	38.79	52.00	84.00%	0.834

Motor Performance Curve

tolerances according to NEMA standard and IEC 60034-1

50 HP | **37.3** kW | **460** Volt | **60** Hertz | **2** Pole

6" 60 HZ SERIES

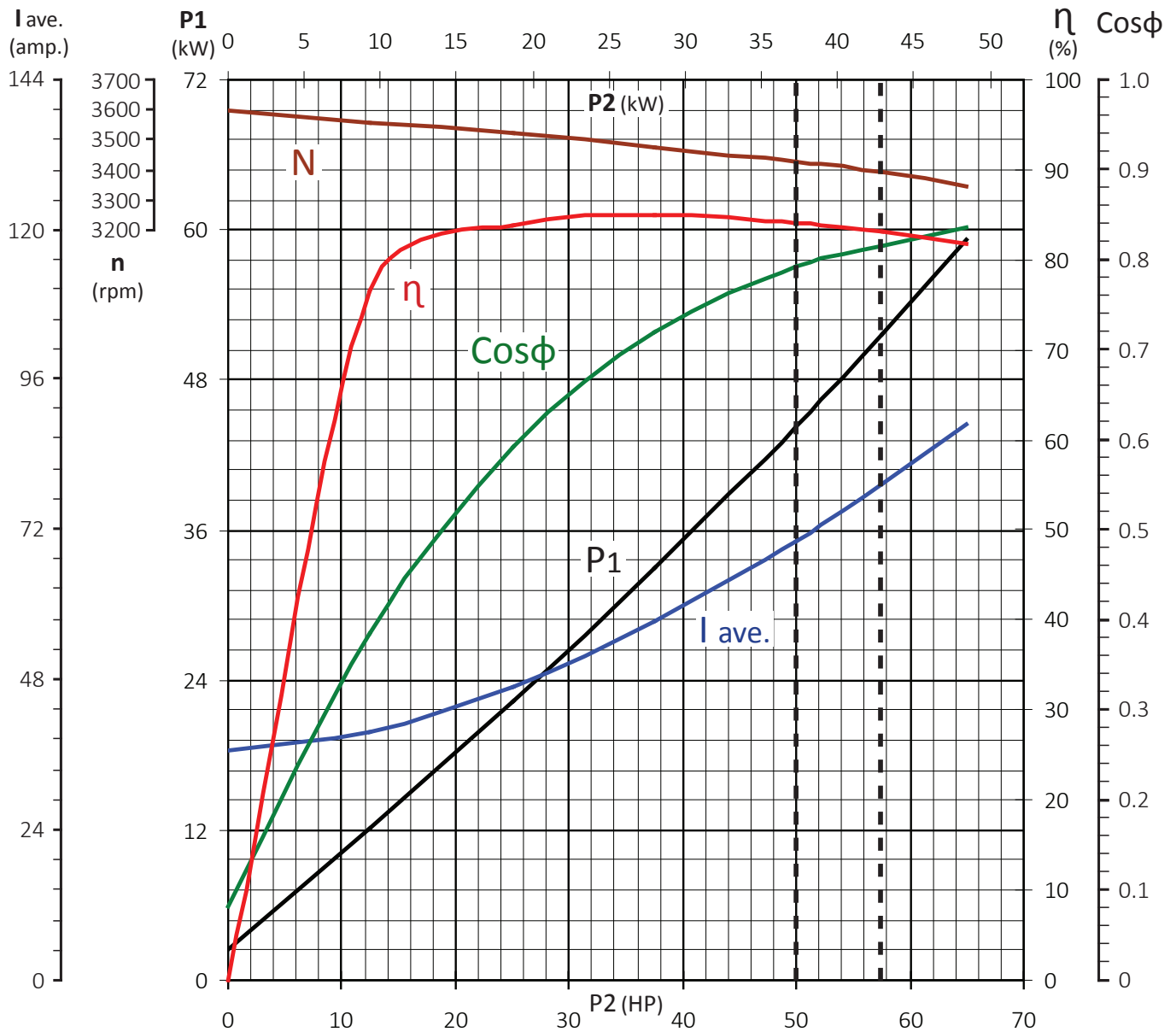

Load	Frequency Hz	Volt ave. V	I ave. A	P1 kW	P1 HP	RPM	Torque Nm	P2 kW	P2 HP	Efficiency %	Cos pi
0%	60.00	460.0	36.75	2.43	3.26	3595.8	0.00	0.00	0.00	0.00%	0.083
25%	60.00	460.0	39.71	12.18	16.33	3556.4	25.04	9.33	12.50	76.56%	0.385
50%	60.00	460.0	47.05	22.23	29.80	3519.1	50.61	18.65	25.00	83.90%	0.593
75%	60.00	460.0	57.42	32.89	44.09	3474.6	76.88	27.98	37.50	85.06%	0.719
100%	60.00	460.0	70.29	44.35	59.45	3425.2	103.99	37.30	50.00	84.10%	0.792
115%	60.00	460.0	79.54	51.65	69.24	3390.3	120.82	42.90	57.50	83.05%	0.815
130%	60.00	460.0	89.00	59.28	79.46	3343.9	138.47	48.49	65.00	81.80%	0.836

Motor Performance Curve

tolerances according to NEMA standard and IEC 60034-1

60 HP | **44.8** kW | **460** Volt | **60** Hertz | **2** Pole

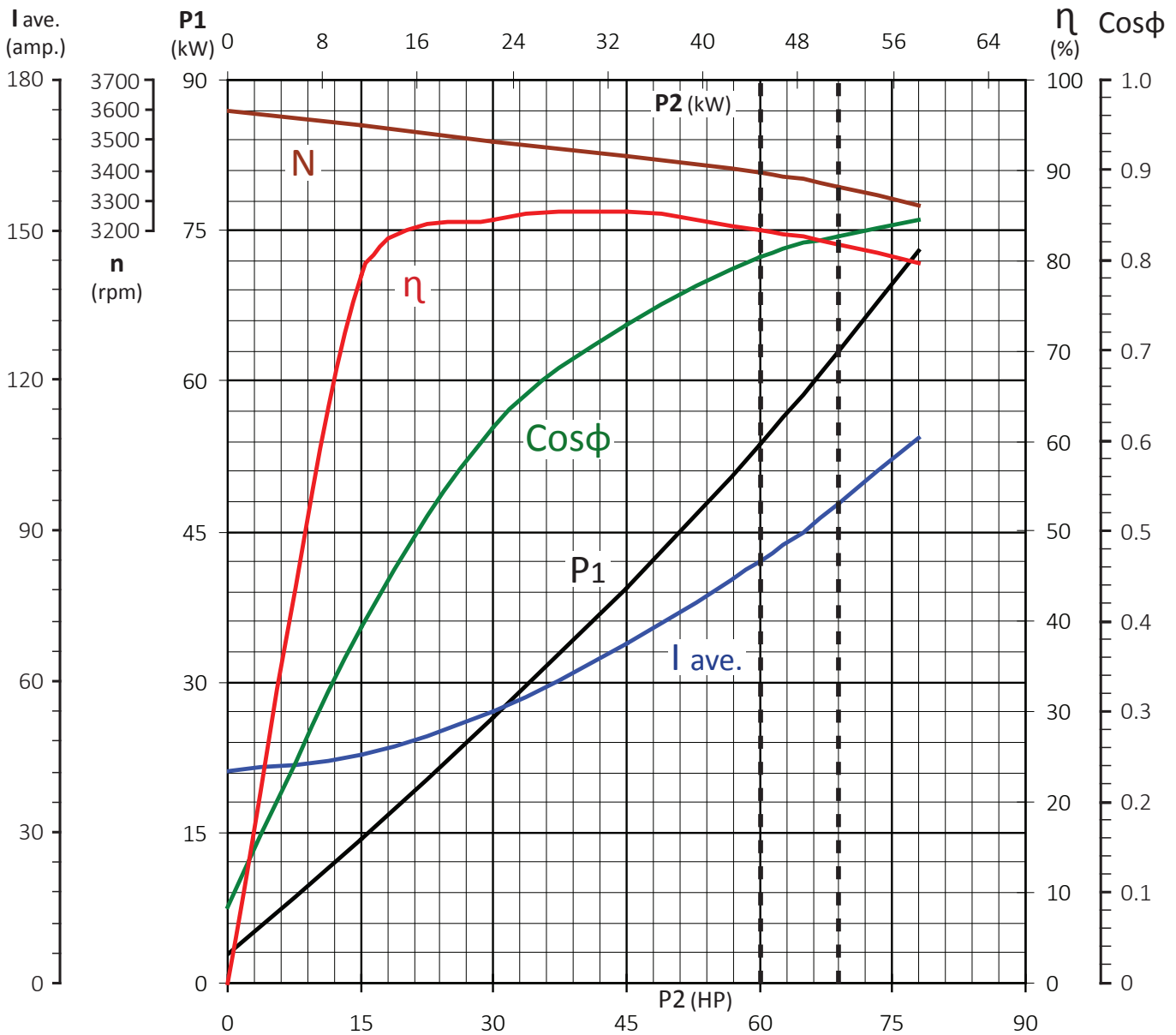

6" 60 HZ SERIES

Load	Frequency Hz	Volt ave. V	I ave. A	P1 kW	P1 HP	RPM	Torque Nm	P2 kW	P2 HP	Efficiency %	Cos pi
0%	60.00	460.0	42.29	2.83	3.79	3594.8	0.00	0.00	0.00	0.00%	0.084
25%	60.00	460.0	45.31	14.26	19.12	3551.6	30.09	11.19	15.00	78.47%	0.395
50%	60.00	460.0	53.98	26.45	35.46	3496.9	61.11	22.38	30.00	84.61%	0.615
75%	60.00	460.0	67.65	39.29	52.67	3449.0	92.95	33.57	45.00	85.44%	0.729
100%	60.00	460.0	83.97	53.72	72.01	3389.8	126.09	44.76	60.00	83.32%	0.803
115%	60.00	460.0	95.55	62.88	84.29	3341.4	147.10	51.47	69.00	81.86%	0.826
130%	60.00	460.0	108.58	73.01	97.87	3283.7	169.22	58.19	78.00	79.70%	0.844

Motor Performance Curve

tolerances according to NEMA standard and IEC 60034-1

75 HP | **55** kW | **460** Volt | **60** Hertz | **2** Pole

6" 60 HZ SERIES

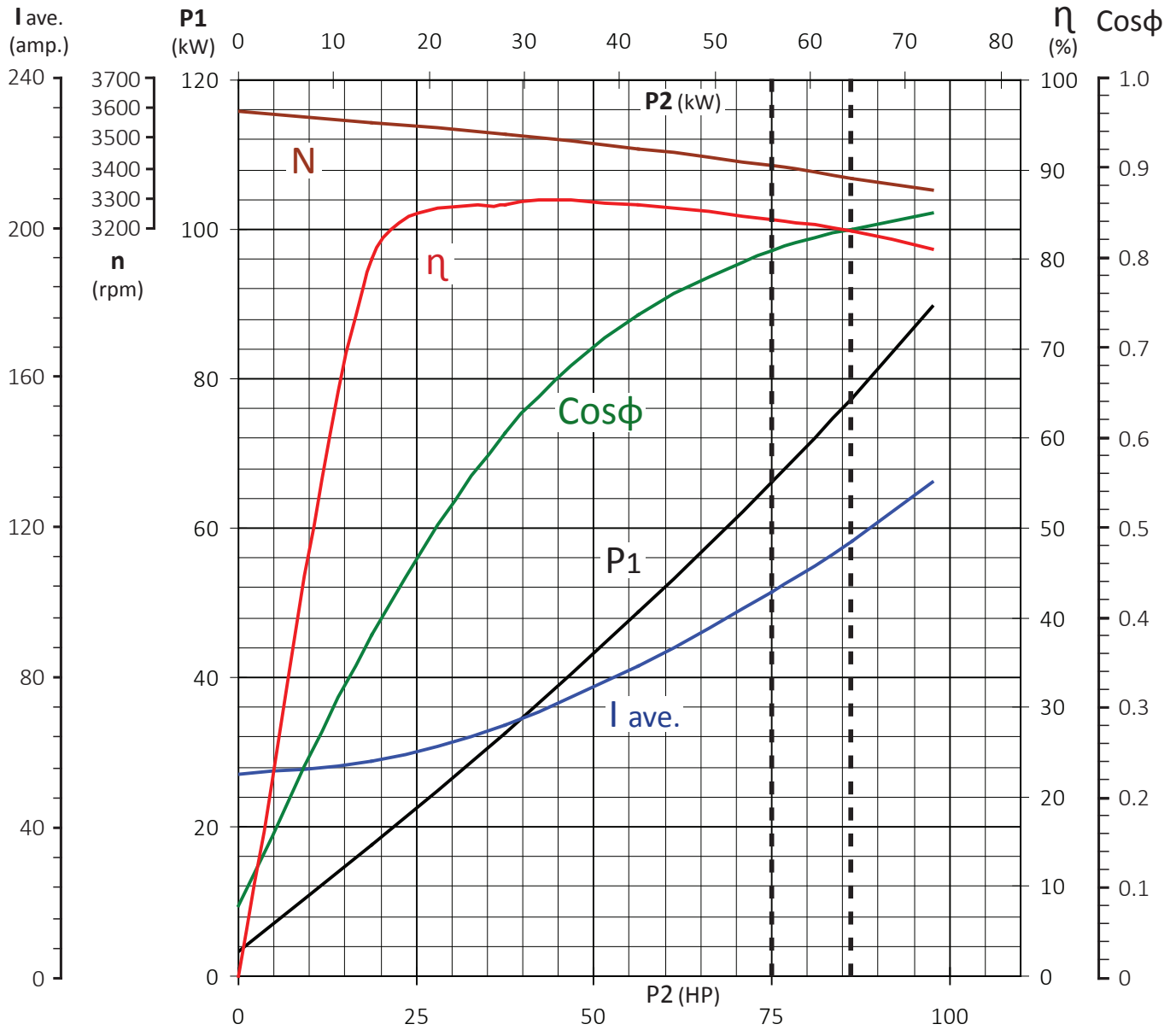

Load	Frequency Hz	Volt ave. V	I ave. A	P1 kW	P1 HP	RPM	Torque Nm	P2 kW	P2 HP	Efficiency %	Cos pi
0%	60.00	460.0	53.91	3.35	4.49	3598.1	0.00	0.00	0.00	0.00%	0.078
25%	60.00	460.0	57.59	17.48	23.43	3558.3	37.54	13.99	18.75	80.02%	0.381
50%	60.00	460.0	67.36	32.52	43.59	3518.1	75.93	27.98	37.50	86.02%	0.606
75%	60.00	460.0	82.86	48.72	65.31	3471.3	115.44	41.96	56.25	86.13%	0.738
100%	60.00	460.0	102.67	66.26	88.82	3414.8	156.46	55.95	75.00	84.44%	0.810
115%	60.00	460.0	116.47	77.39	103.74	3372.2	182.20	64.34	86.25	83.14%	0.834
130%	60.00	460.0	132.17	89.72	120.27	3329.7	208.60	72.74	97.50	81.07%	0.852

Electrical DATA

Electrical Data @ 50 Hz - Three Phase - 380 Volt - 2 Pole

Motor Type	Motor Size		Thrust Load (lbs)	RPM	Full Load Current (Amps)	Starting Current (Amps)	KVA Code	Cos. Φ at Full Load	Efficiency at Full Load (%)	Service Factor
	HP	kW								
6SME 055T	5.5	4	6000	2760	10.5	53	H	0.81	72.9	1
6SME 075T	7.5	5.5	6000	2750	14.0	60	F	0.82	73.7	1
6SME 100T	10	7.5	6000	2770	17.7	73	E	0.84	76.7	1
6SME 150T	15	11	6000	2775	26.1	106	E	0.83	78.1	1
6SME 200T	20	15	6000	2800	33.9	159	F	0.85	78.9	1
6SME 250T	25	18.5	6000	2800	41.2	187	E	0.84	81.7	1
6SME 300T	30	22	6000	2795	49.9	246	F	0.84	81.1	1
6SME 400T	40	30	6000	2815	65.2	350	G	0.83	83.4	1
6SME 500T	50	37	6000	2770	82.9	451	G	0.84	81.0	1
6SME 600T	60	45	13849	2720	102.0	557	G	0.85	78.6	1
6SME 750T	75	55	13849	2760	125.6	691	G	0.85	79.6	1

3 Phase - 380V - 50 Hz

6" 50 HZ SERIES

Technical DETAILS

Size & Dimensions Motor Leads @ 50 Hz - 380 Volt

Sr: No.	Volt	Motor Size		Lead Size			Dimension B x H (inch)	Cable Length (Feet)	Qty (Nr.)
		HP	kW	Core	mm ²	AWG			
DOL	380V	5.5 ~ 30	4 ~ 22	3	6	10	0.75 x 0.31	13	1
				1	12	6	D = 0.27	13	1
				3	10	8	0.95 x 0.35	13	1
SD	380V	5.5 ~ 60	4 ~ 45	1	16*	6	D = 0.45	13	3
				1	12	6	D = 0.27	13	1

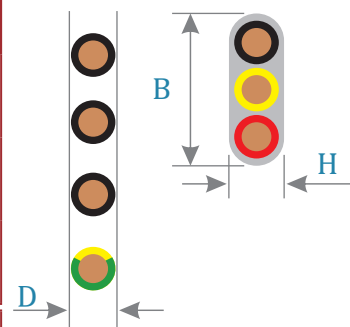

* 1 x 16 mm² as black color used for all three (3) wires.

Motor Performance Curve

tolerances according to NEMA standard and IEC 60034-1

5.5 HP | **4.1** kW | **380** Volt | **50** Hertz | **2** Pole

6" 50 HZ SERIES

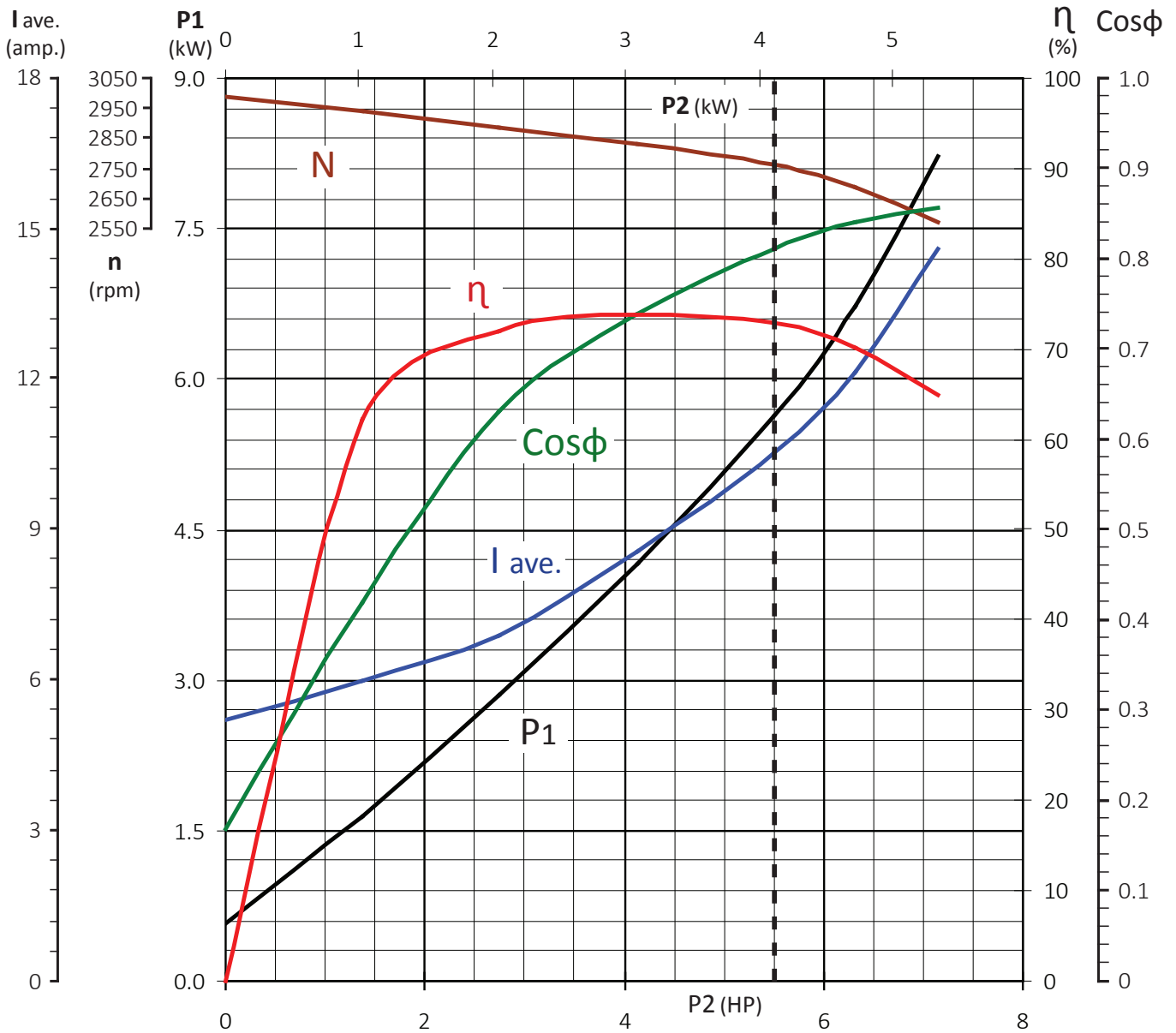

Load	Frequency Hz	Volt ave. V	I ave. A	P1 kW	P1 HP	RPM	Torque Nm	P2 kW	P2 HP	Efficiency %	Cos pi
0%	50.00	380.0	5.21	0.58	0.78	2988.1	0.00	0.00	0.00	0.00%	0.169
25%	50.00	380.0	6.00	1.65	2.21	2942.8	3.33	1.03	1.38	62.17%	0.418
50%	50.00	380.0	6.87	2.85	3.82	2887.3	6.79	2.05	2.75	71.98%	0.630
75%	50.00	380.0	8.59	4.17	5.59	2832.1	10.38	3.08	4.13	73.79%	0.738
100%	50.00	380.0	10.53	5.63	7.55	2760.2	14.20	4.10	5.50	72.88%	0.812
115%	50.00	380.0	12.14	6.72	9.01	2684.8	16.78	4.72	6.33	70.22%	0.841
130%	50.00	380.0	14.59	8.23	11.03	2569.4	19.82	5.33	7.15	64.81%	0.857

Motor Performance Curve

tolerances according to NEMA standard and IEC 60034-1

7.5 HP | **5.6** kW | **380** Volt | **50** Hertz | **2** Pole

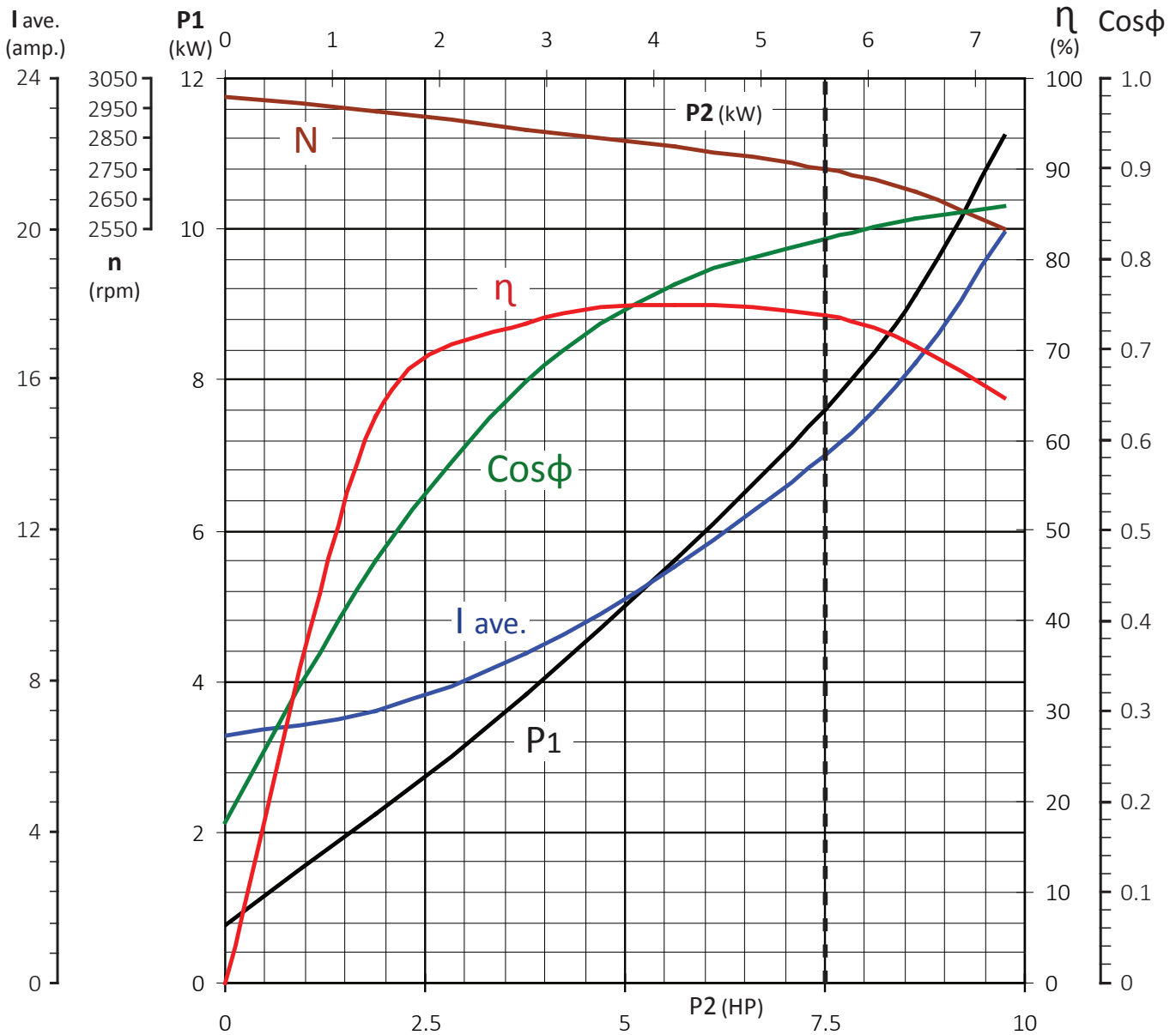

6" 50 HZ SERIES

Load	Frequency Hz	Volt ave. V	I ave. A	P1 kW	P1 HP	RPM	Torque Nm	P2 kW	P2 HP	Efficiency %	Cos pi
0%	50.00	380.0	6.57	0.77	1.03	2987.4	0.00	0.00	0.00	0.00%	0.178
25%	50.00	380.0	7.24	2.23	2.99	2940.1	4.54	1.40	1.88	62.72%	0.468
50%	50.00	380.0	8.77	3.84	5.15	2882.3	9.27	2.80	3.75	72.85%	0.665
75%	50.00	380.0	11.02	5.60	7.51	2824.8	14.19	4.20	5.63	74.93%	0.772
100%	50.00	380.0	14.01	7.59	10.17	2749.8	19.43	5.60	7.50	73.72%	0.823
115%	50.00	380.0	16.45	9.14	12.25	2671.2	23.00	6.43	8.63	70.40%	0.844
130%	50.00	380.0	19.89	11.23	15.05	2550.9	27.23	7.27	9.75	64.77%	0.858

Motor Performance Curve

tolerances according to NEMA standard and IEC 60034-1

10 HP | **7.5** kW | **380** Volt | **50** Hertz | **2** Pole

6" 50 HZ SERIES

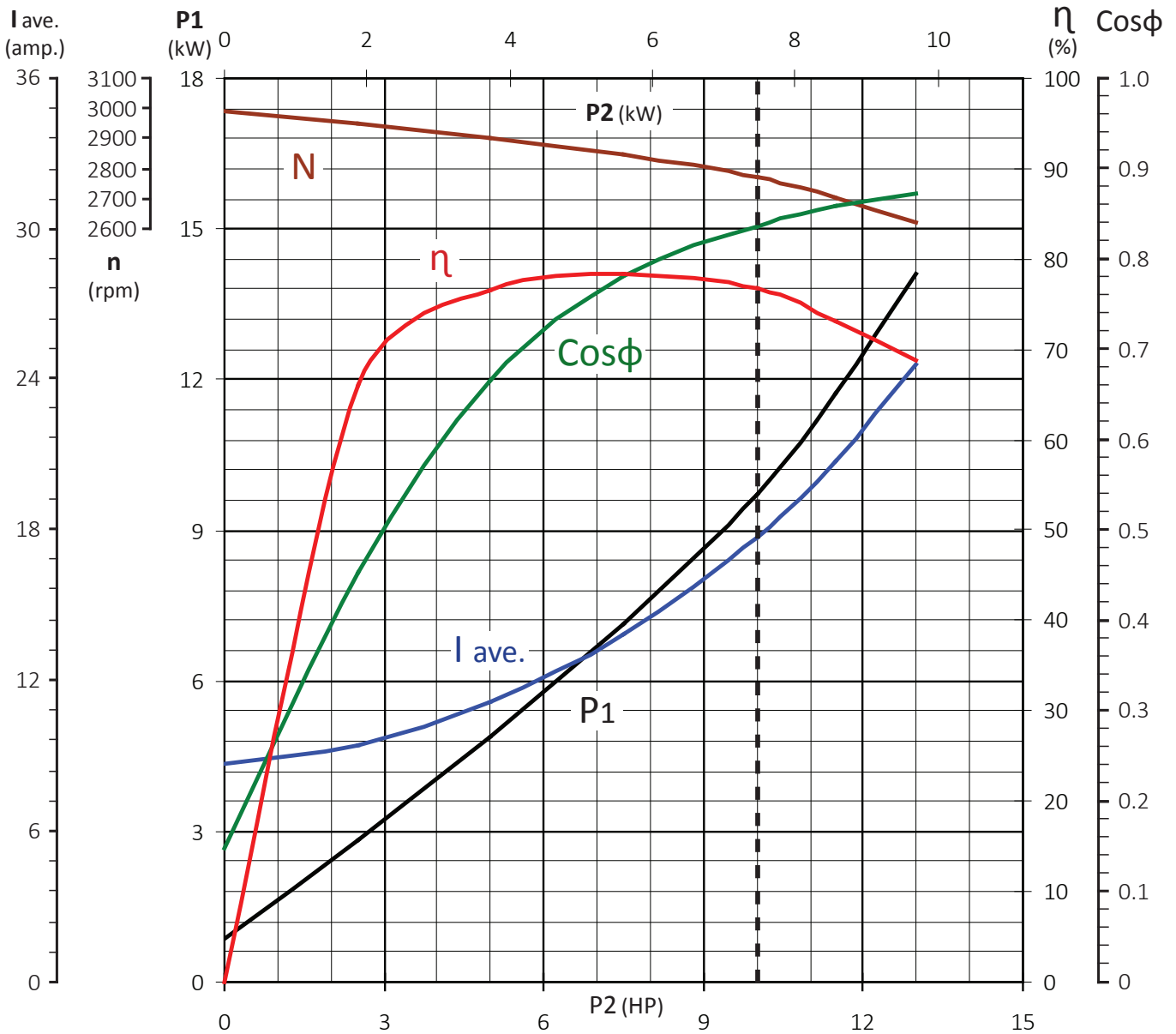

Load	Frequency Hz	Volt ave. V	I ave. A	P1 kW	P1 HP	RPM	Torque Nm	P2 kW	P2 HP	Efficiency %	Cos pi
0%	50.00	380.0	8.67	0.85	1.14	2991.0	0.00	0.00	0.00	0.00%	0.149
25%	50.00	380.0	9.44	2.82	3.78	2950.1	6.04	1.87	2.50	66.13%	0.454
50%	50.00	380.0	11.15	4.88	6.54	2903.7	12.27	3.73	5.00	76.43%	0.665
75%	50.00	380.0	13.89	7.14	9.57	2843.9	18.79	5.60	7.50	78.36%	0.781
100%	50.00	380.0	17.68	9.73	13.04	2770.4	25.71	7.46	10.00	76.67%	0.836
115%	50.00	380.0	20.73	11.72	15.71	2706.1	30.27	8.58	11.50	73.20%	0.859
130%	50.00	380.0	24.57	14.12	18.93	2619.4	35.35	9.70	13.00	68.68%	0.873

Motor Performance Curve

tolerances according to NEMA standard and IEC 60034-1

15 HP | **11.2** kW | **380** Volt | **50** Hertz | **2** Pole

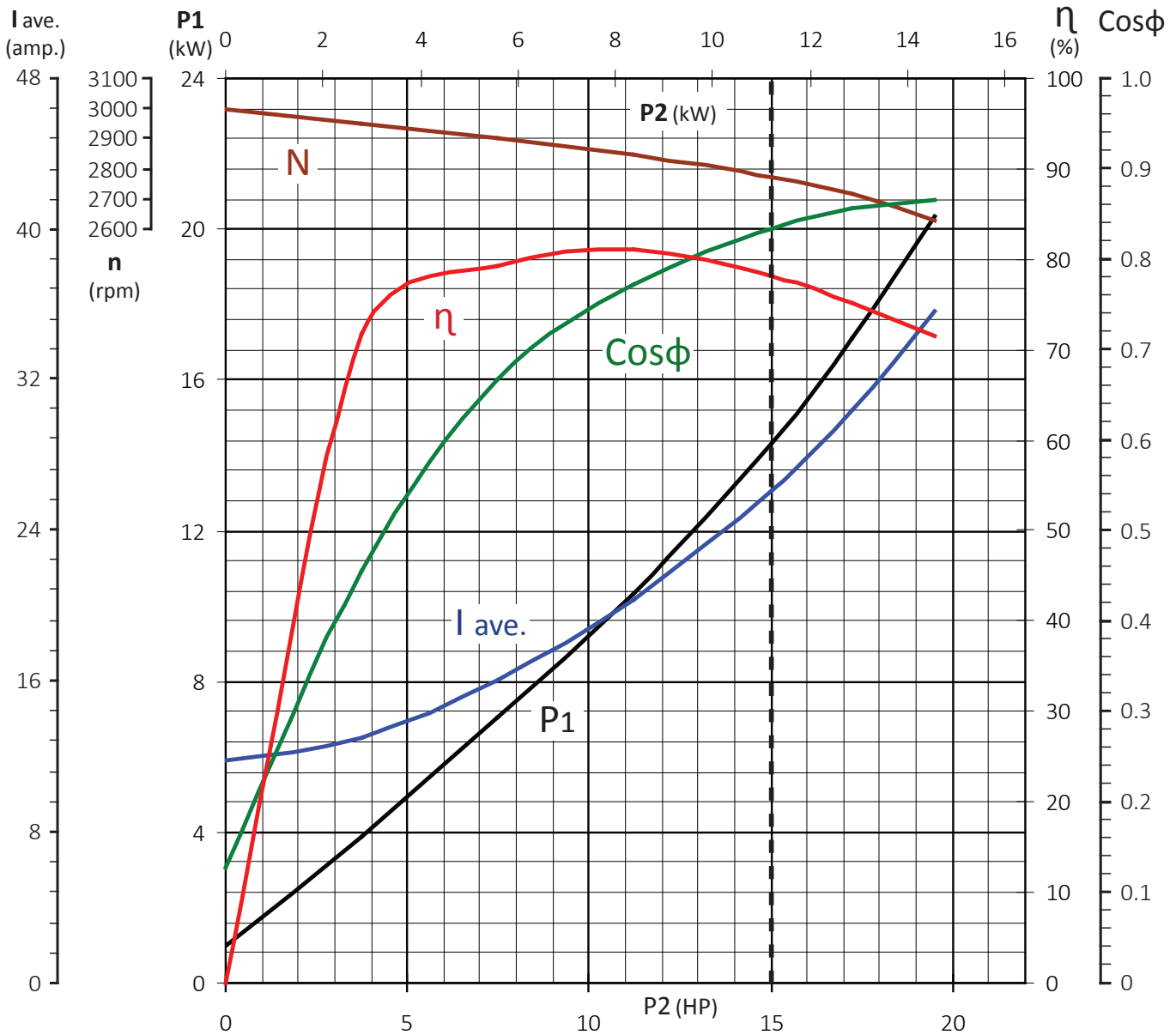

6" 50 HZ SERIES

Load	Frequency Hz	Volt ave. V	I ave. A	P1 kW	P1 HP	RPM	Torque Nm	P2 kW	P2 HP	Efficiency %	Cos pi
0%	50.00	380.0	11.84	0.99	1.33	2995.4	0.00	0.00	0.00	0.00%	0.127
25%	50.00	380.0	13.02	3.90	5.23	2951.5	9.05	2.80	3.75	71.73%	0.455
50%	50.00	380.0	16.06	7.05	9.45	2904.2	18.40	5.60	7.50	79.36%	0.667
75%	50.00	380.0	20.37	10.35	13.87	2848.6	28.13	8.39	11.25	81.09%	0.772
100%	50.00	380.0	26.09	14.32	19.20	2774.7	38.51	11.19	15.00	78.14%	0.834
115%	50.00	380.0	30.35	17.12	22.95	2714.4	45.27	12.87	17.25	75.17%	0.857
130%	50.00	380.0	35.63	20.31	27.23	2631.5	52.79	14.55	19.50	71.62%	0.866

Motor Performance Curve

tolerances according to NEMA standard and IEC 60034-1

20 HP | **14.9** kW | **380** Volt | **50** Hertz | **2** Pole

6" 50 HZ SERIES

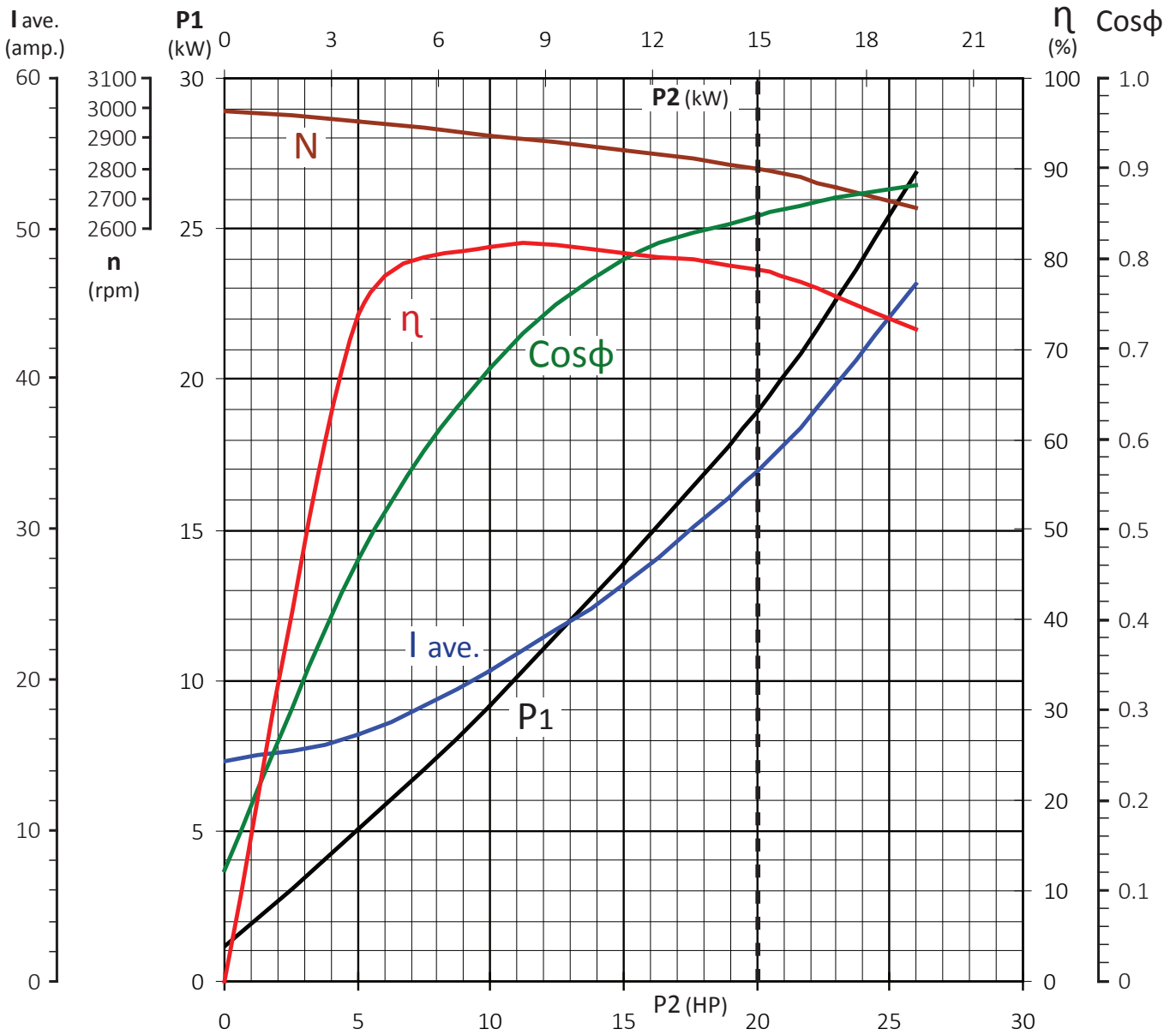

Load	Frequency Hz	Volt ave. V	I ave. A	P1 kW	P1 HP	RPM	Torque Nm	P2 kW	P2 HP	Efficiency %	Cos pi
0%	50.00	380.0	14.58	1.19	1.60	2992.3	0.00	0.00	0.00	0.00%	0.124
25%	50.00	380.0	16.40	5.05	6.77	2955.4	12.05	3.73	5.00	73.86%	0.468
50%	50.00	380.0	20.57	9.18	12.31	2909.8	24.48	7.46	10.00	81.26%	0.678
75%	50.00	380.0	26.39	13.88	18.61	2858.8	37.38	11.19	15.00	80.62%	0.799
100%	50.00	380.0	33.90	18.92	25.36	2799.7	50.89	14.92	20.00	78.86%	0.848
115%	50.00	380.0	39.64	22.62	30.32	2739.3	59.81	17.16	23.00	75.85%	0.867
130%	50.00	380.0	46.36	26.88	36.03	2672.2	69.31	19.40	26.00	72.16%	0.881

Motor Performance Curve

tolerances according to NEMA standard and IEC 60034-1

25 HP | **18.6** kW | **380** Volt | **50** Hertz | **2** Pole

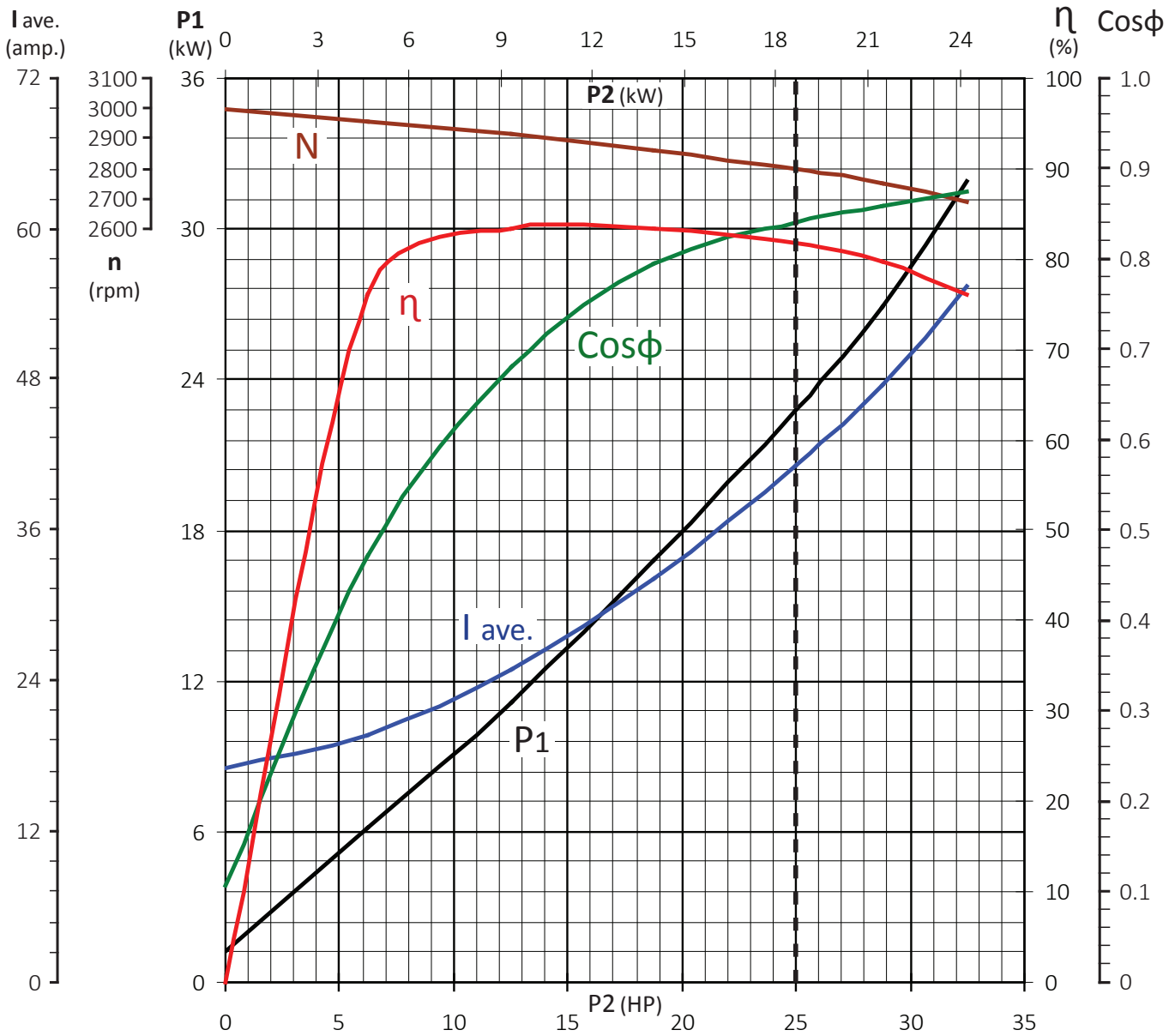

6" 50 HZ SERIES

Load	Frequency Hz	Volt ave. V	I ave. A	P1 kW	P1 HP	RPM	Torque Nm	P2 kW	P2 HP	Efficiency %	Cos pi
0%	50.00	380.0	17.06	1.19	1.60	2996.3	0.00	0.00	0.00	0.00%	0.106
25%	50.00	380.0	19.70	6.12	8.20	2956.1	15.06	4.66	6.25	76.18%	0.472
50%	50.00	380.0	24.91	11.18	14.99	2913.5	30.56	9.33	12.50	83.41%	0.682
75%	50.00	380.0	32.11	16.78	22.49	2863.9	46.64	13.99	18.75	83.36%	0.794
100%	50.00	380.0	41.23	22.82	30.59	2800.1	63.60	18.65	25.00	81.73%	0.841
115%	50.00	380.0	47.62	26.92	36.09	2753.9	74.37	21.45	28.75	79.67%	0.859
130%	50.00	380.0	55.48	31.91	42.78	2689.3	86.09	24.25	32.50	75.97%	0.874

Motor Performance Curve

tolerances according to NEMA standard and IEC 60034-1

30 HP | **22.4** kW | **380** Volt | **50** Hertz | **2** Pole

6" 50 HZ SERIES

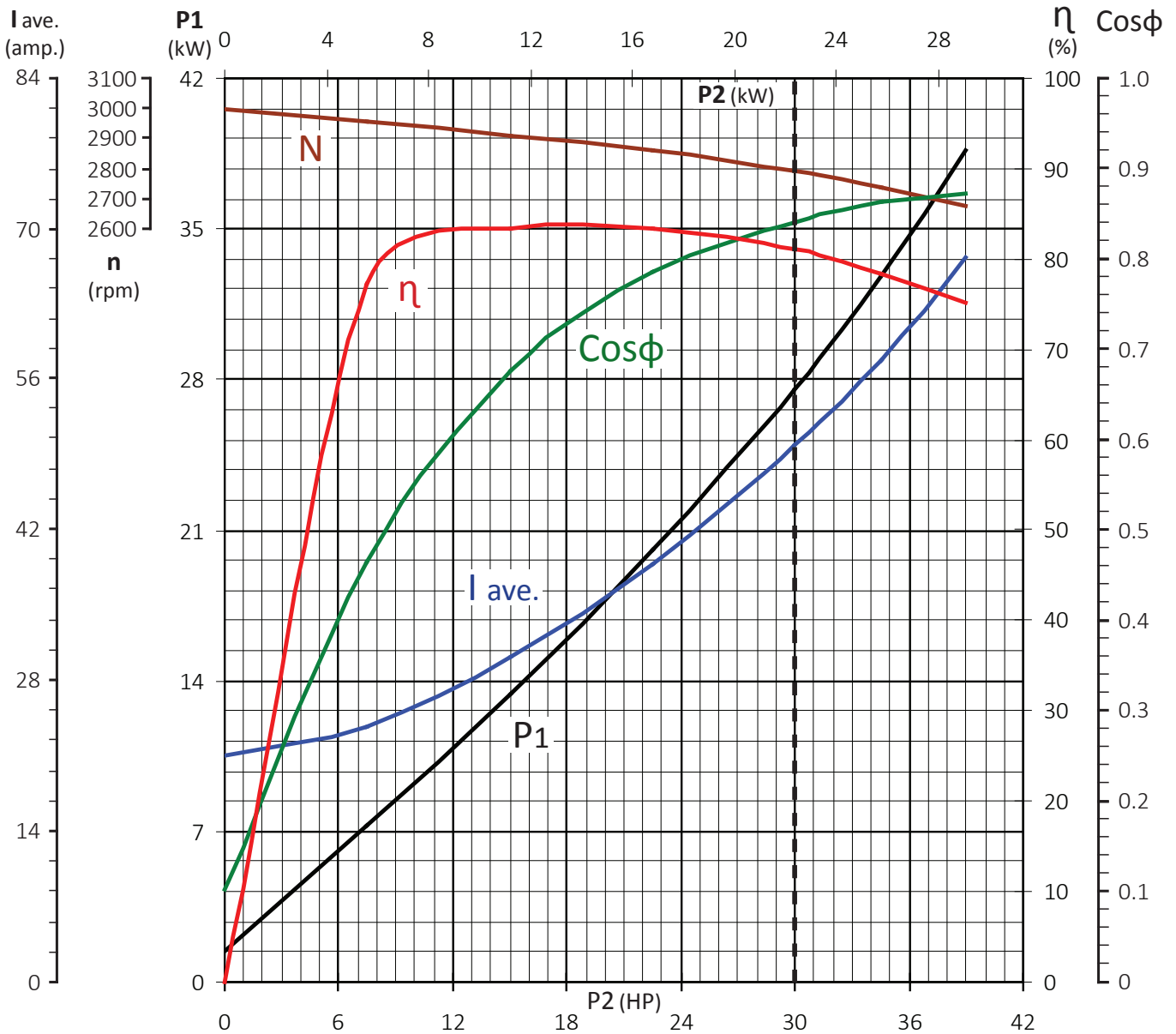

Load	Frequency Hz	Volt ave. V	I ave. A	P1 kW	P1 HP	RPM	Torque Nm	P2 kW	P2 HP	Efficiency %	Cos pi
0%	50.00	380.0	21.00	1.41	1.89	2997.5	0.00	0.00	0.00	0.00%	0.102
25%	50.00	380.0	23.69	7.25	9.72	2958.9	18.06	5.60	7.50	77.17%	0.465
50%	50.00	380.0	30.14	13.41	17.98	2909.7	36.72	11.19	15.00	83.45%	0.676
75%	50.00	380.0	38.89	20.12	26.97	2858.5	56.07	16.79	22.50	83.42%	0.786
100%	50.00	380.0	49.90	27.59	36.98	2794.9	76.47	22.38	30.00	81.12%	0.840
115%	50.00	380.0	57.82	32.84	44.02	2738.5	89.75	25.74	34.50	78.37%	0.863
130%	50.00	380.0	67.40	38.68	51.85	2678.0	103.74	29.09	39.00	75.22%	0.872

Motor Performance Curve

tolerances according to NEMA standard and IEC 60034-1

40 HP | **29.8** kW | **380** Volt | **50** Hertz | **2** Pole

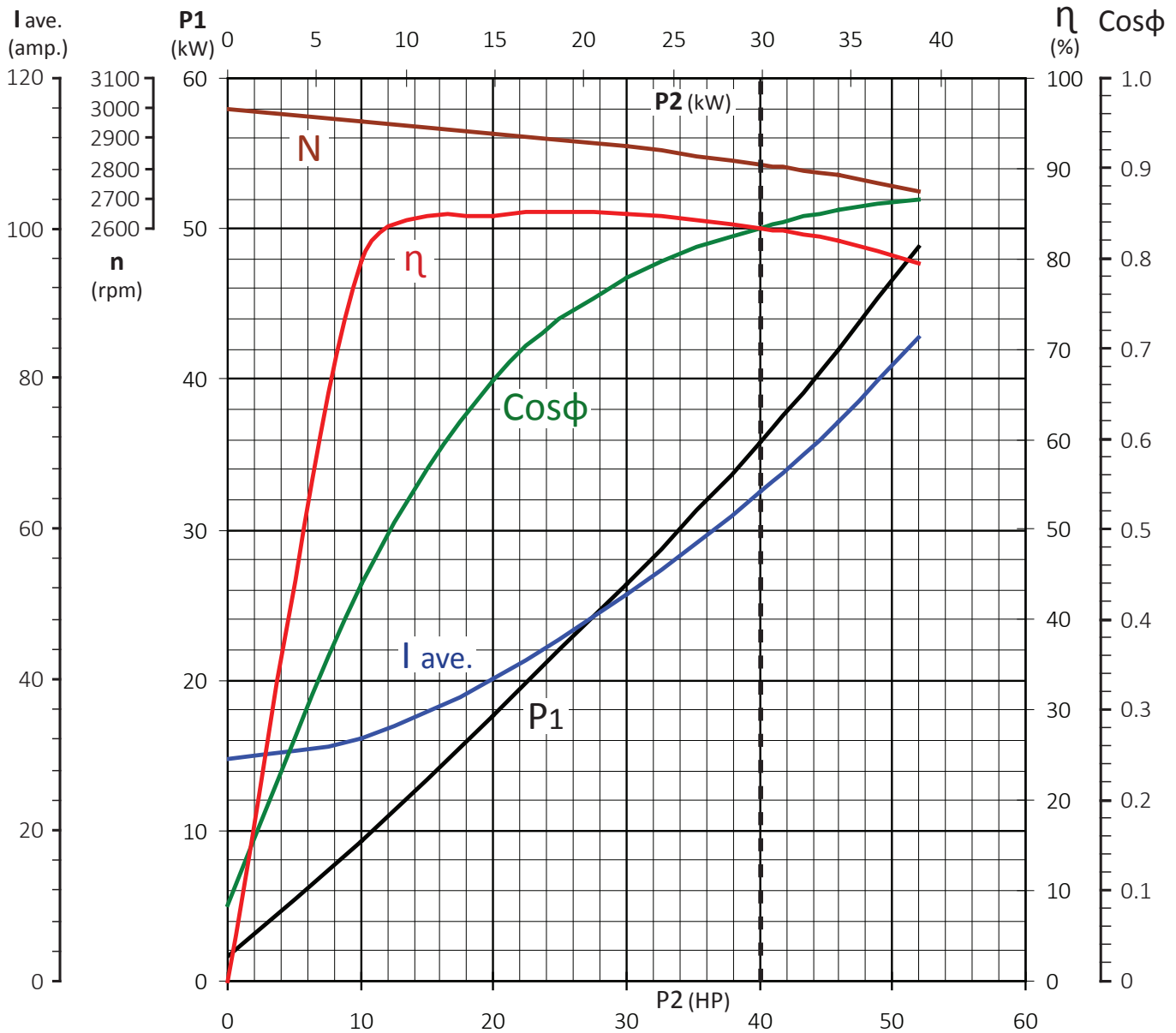

6" 50 HZ SERIES

Load	Frequency Hz	Volt ave. V	I ave. A	P1 kW	P1 HP	RPM	Torque Nm	P2 kW	P2 HP	Efficiency %	Cos pi
0%	50.00	380.0	29.49	1.65	2.21	2998.3	0.00	0.00	0.00	0.00%	0.085
25%	50.00	380.0	32.32	9.36	12.55	2959.5	24.07	7.46	10.00	79.70%	0.440
50%	50.00	380.0	40.22	17.63	23.63	2918.0	48.83	14.92	20.00	84.63%	0.666
75%	50.00	380.0	51.35	26.36	35.34	2871.6	74.42	22.38	30.00	84.90%	0.780
100%	50.00	380.0	65.18	35.78	47.96	2815.2	101.22	29.84	40.00	83.40%	0.834
115%	50.00	380.0	74.46	41.90	56.17	2776.4	118.03	34.32	46.00	81.90%	0.855
130%	50.00	380.0	85.58	48.78	65.39	2725.2	135.93	38.79	52.00	79.52%	0.866

Motor Performance Curve

tolerances according to NEMA standard and IEC 60034-1

50 HP | **37.3** kW | **380** Volt | **50** Hertz | **2** Pole

6" 50 HZ SERIES

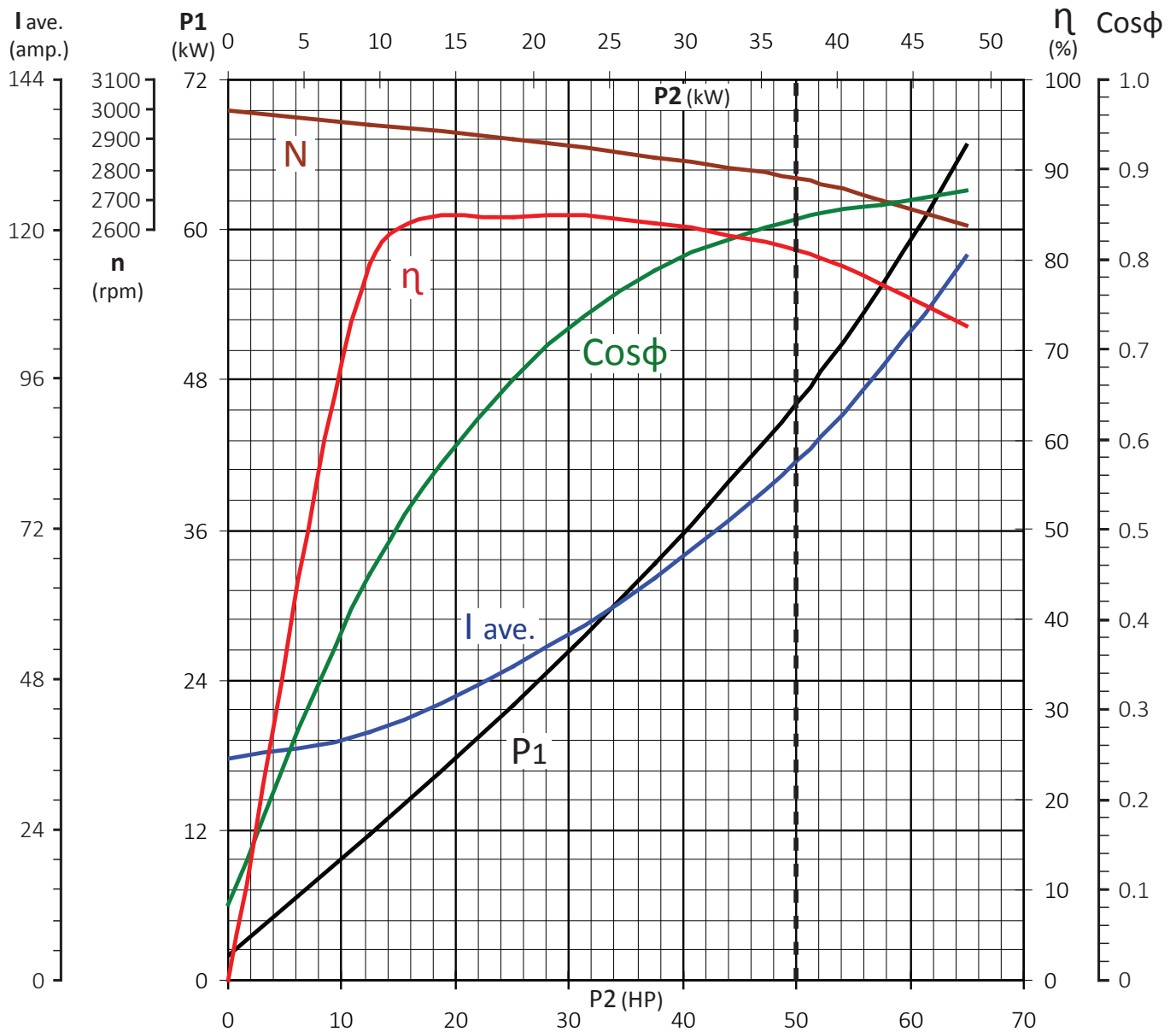

Load	Frequency Hz	Volt ave. V	I ave. A	P1 kW	P1 HP	RPM	Torque Nm	P2 kW	P2 HP	Efficiency %	Cos pi
0%	50.00	380.0	35.27	1.95	2.61	2998.3	0.00	0.00	0.00	0.00%	0.084
25%	50.00	380.0	39.57	11.72	15.71	2951.6	30.17	9.33	12.50	79.56%	0.450
50%	50.00	380.0	50.16	22.02	29.52	2905.2	61.30	18.65	25.00	84.70%	0.667
75%	50.00	380.0	64.15	33.31	44.65	2842.4	93.99	27.98	37.50	83.98%	0.789
100%	50.00	380.0	82.90	46.05	61.73	2769.9	128.59	37.30	50.00	81.00%	0.844
115%	50.00	380.0	98.06	55.63	74.57	2698.6	151.79	42.90	57.50	77.11%	0.862
130%	50.00	380.0	115.63	66.82	89.57	2612.3	177.25	48.49	65.00	72.57%	0.878

Motor Performance Curve

tolerances according to NEMA standard and IEC 60034-1

60 HP | **44.8** kW | **380** Volt | **50** Hertz | **2** Pole

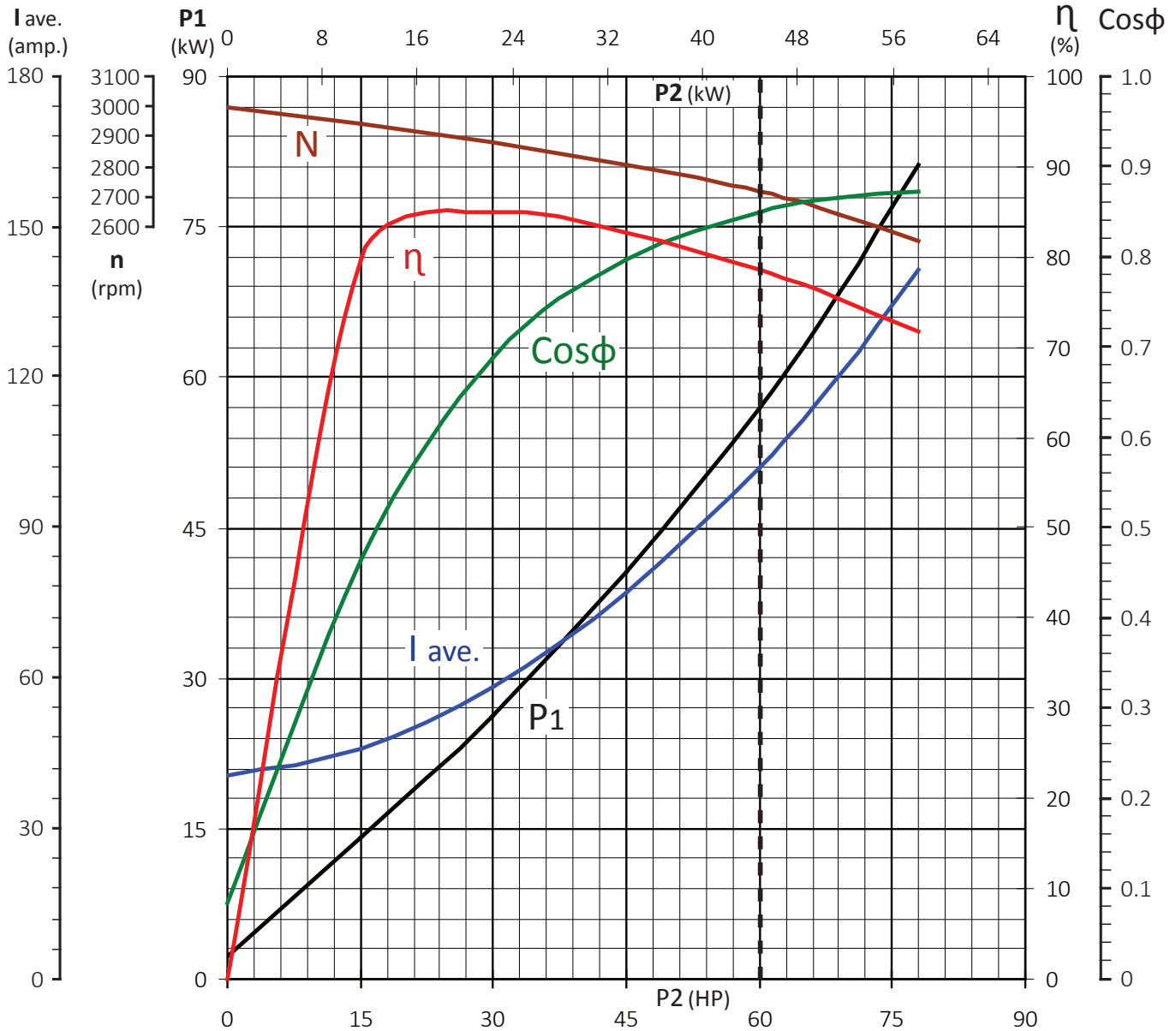

6" 50 HZ SERIES

Load	Frequency Hz	Volt ave. V	I ave. A	P1 kW	P1 HP	RPM	Torque Nm	P2 kW	P2 HP	Efficiency %	Cos pi
0%	50.00	380.0	40.52	2.24	3.00	2994.3	0.00	0.00	0.00	0.00%	0.084
25%	50.00	380.0	45.91	14.05	18.83	2942.5	36.31	11.19	15.00	79.64%	0.465
50%	50.00	380.0	58.21	26.32	35.28	2881.7	74.16	22.38	30.00	85.03%	0.687
75%	50.00	380.0	77.21	40.55	54.36	2805.3	114.27	33.57	45.00	82.79%	0.798
100%	50.00	380.0	101.97	56.98	76.38	2719.8	157.15	44.76	60.00	78.55%	0.849
115%	50.00	380.0	120.06	68.35	91.62	2644.2	185.89	51.47	69.00	75.31%	0.865
130%	50.00	380.0	141.38	81.14	108.77	2556.0	217.39	58.19	78.00	71.71%	0.872

Motor Performance Curve

tolerances according to NEMA standard and IEC 60034-1

75 HP | **55** kW | **380** Volt | **50** Hertz | **2** Pole

6" 50 HZ SERIES

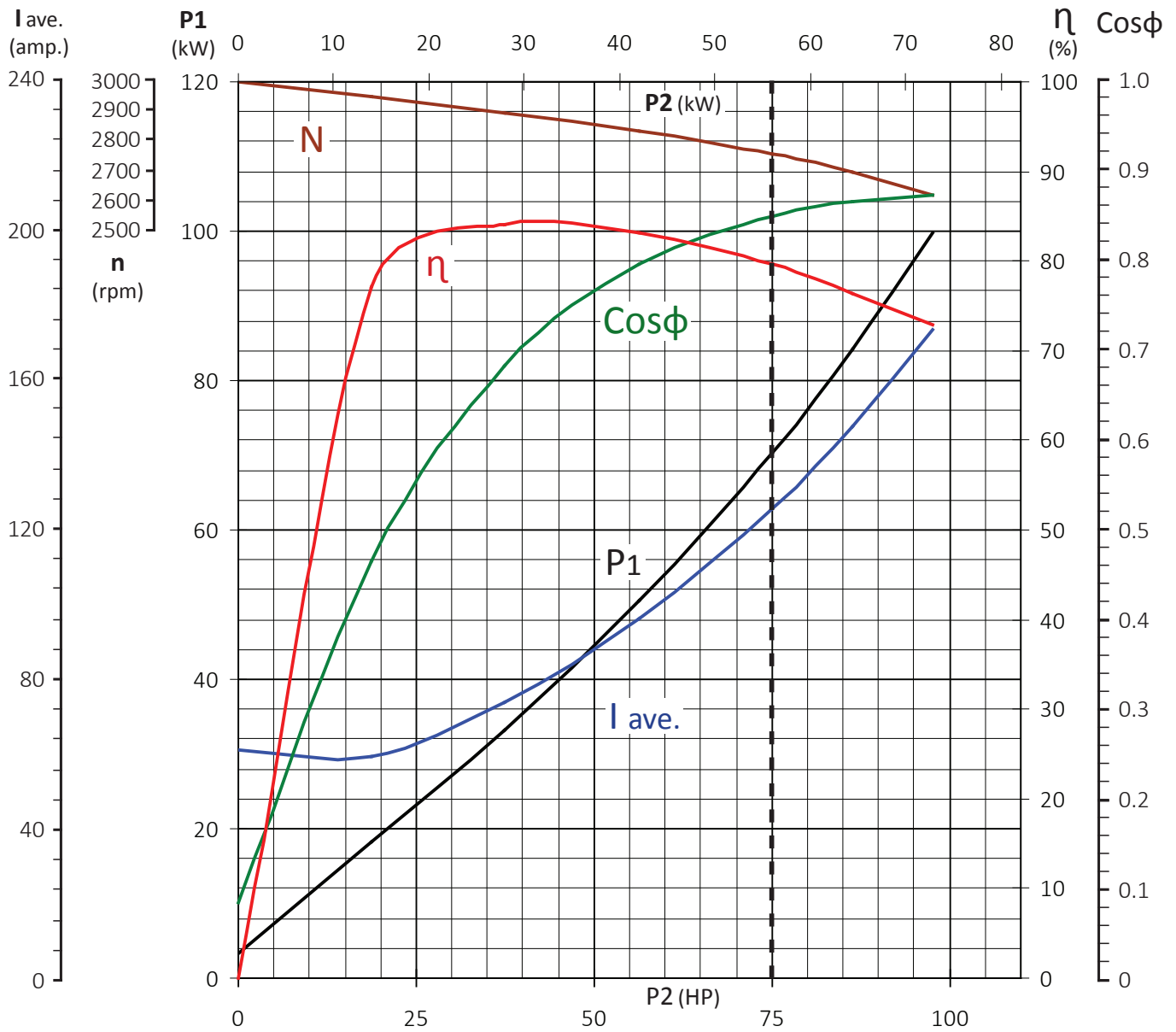

Load	Frequency Hz	Volt ave. V	I ave. A	P1 kW	P1 HP	RPM	Torque Nm	P2 kW	P2 HP	Efficiency %	Cos pi
0%	50.00	380.0	61.32	3.39	4.54	2999.2	0.00	0.00	0.00	0.00%	0.084
25%	50.00	380.0	59.27	18.14	24.32	2949.8	45.28	13.99	18.75	77.11%	0.465
50%	50.00	380.0	73.86	33.25	44.57	2894.9	92.28	27.98	37.50	84.14%	0.684
75%	50.00	380.0	96.37	50.49	67.68	2834.7	141.36	41.96	56.25	83.11%	0.796
100%	50.00	380.0	125.57	70.25	94.17	2760.4	193.55	55.95	75.00	79.64%	0.850
115%	50.00	380.0	147.69	84.18	112.84	2698.1	227.73	64.34	86.25	76.43%	0.866
130%	50.00	380.0	173.46	99.78	133.75	2623.2	264.78	72.74	97.50	72.90%	0.874

Technical DETAILS

Motor Dimensions and Weights

Motor Type	Motor Size		L Motor Length (inch)	L1 Motor Length (inch)	Packing Dimension W x H x L (inch)	Weight (Lbs)	
	HP	kW				Without Packing	With Packing
6SME 055T	5.5	4	32.2	29.3	10.4 x 13.8 x 37.4	126	149
6SME 075T	7.5	5.5	32.2	29.3	10.4 x 13.8 x 37.4	126	149
6SME 100T	10	7.5	34.2	31.3	10.4 x 13.8 x 37.4	137	160
6SME 150T	15	11	37.5	34.6	10.4 x 13.8 x 40.3	155	178
6SME 200T	20	15	41.0	38.1	10.4 x 13.8 x 44.4	175	201
6SME 250T	25	18.5	44.8	41.9	10.4 x 13.8 x 47.4	197	224
6SME 300T	30	22	47.9	45.0	10.4 x 13.8 x 51.3	217	247
6SME 400T	40	30	53.4	50.5	10.4 x 13.8 x 56.9	250	280
6SME 500T	50	37	53.4	50.5	10.4 x 13.8 x 56.9	250	280
6SME 600T	60	45	56.1	53.2	10.4 x 13.8 x 59.3	269	301
6SME 750T	75	55	60.8	57.9	10.4 x 13.8 x 64.0	291	325

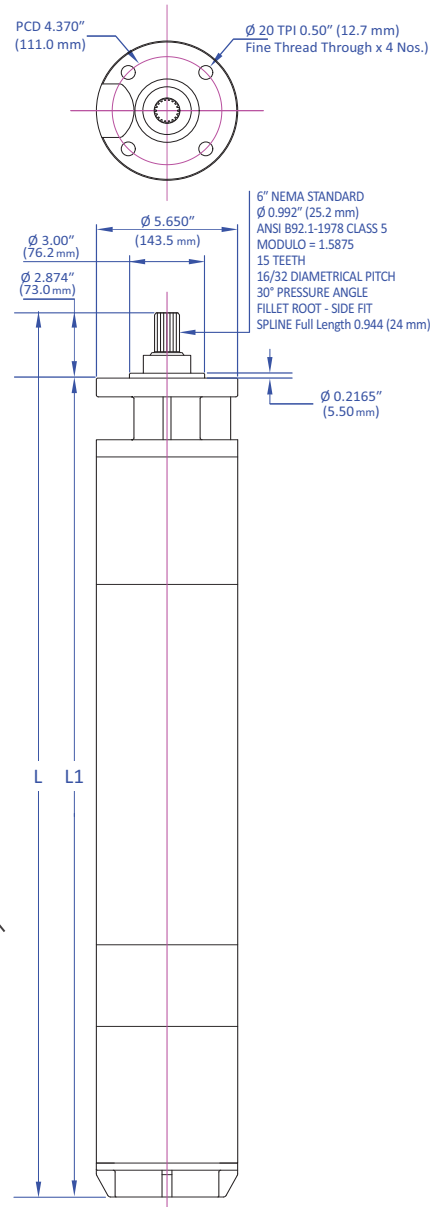

6" SERIES

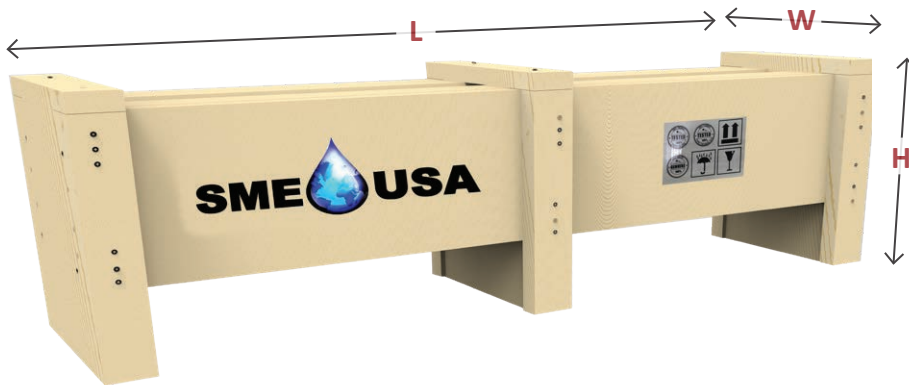

Exploded VIEW

Cross-Sectional VIEW

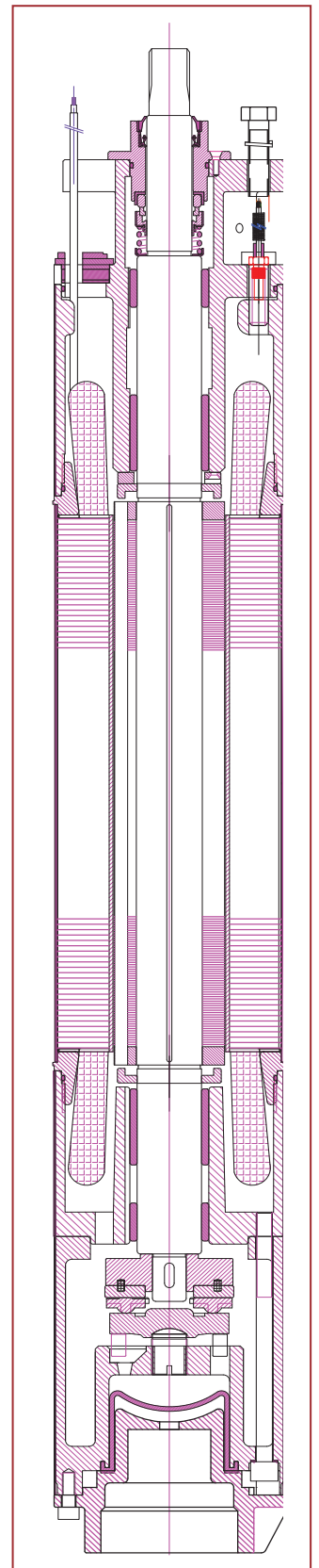
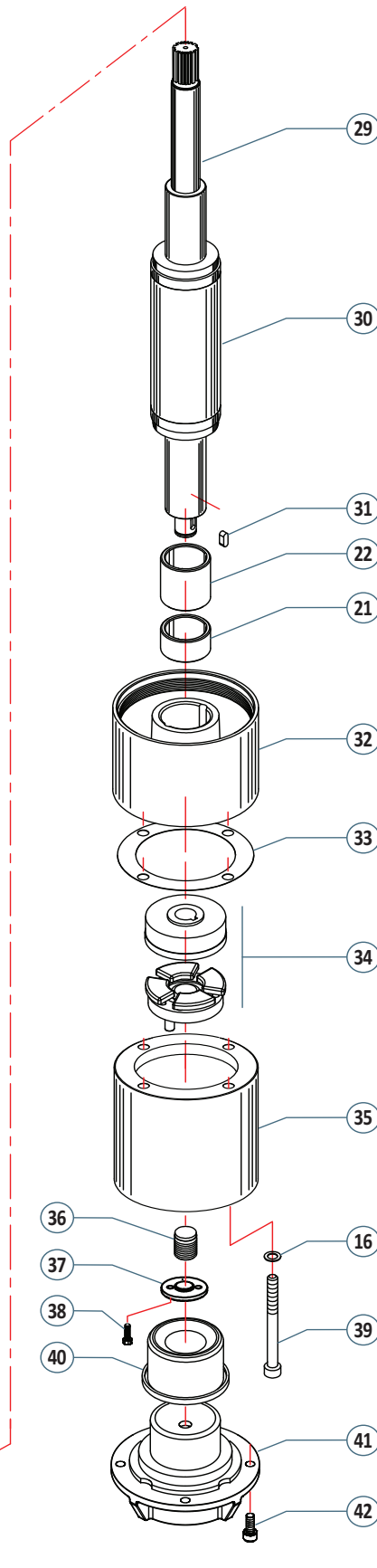
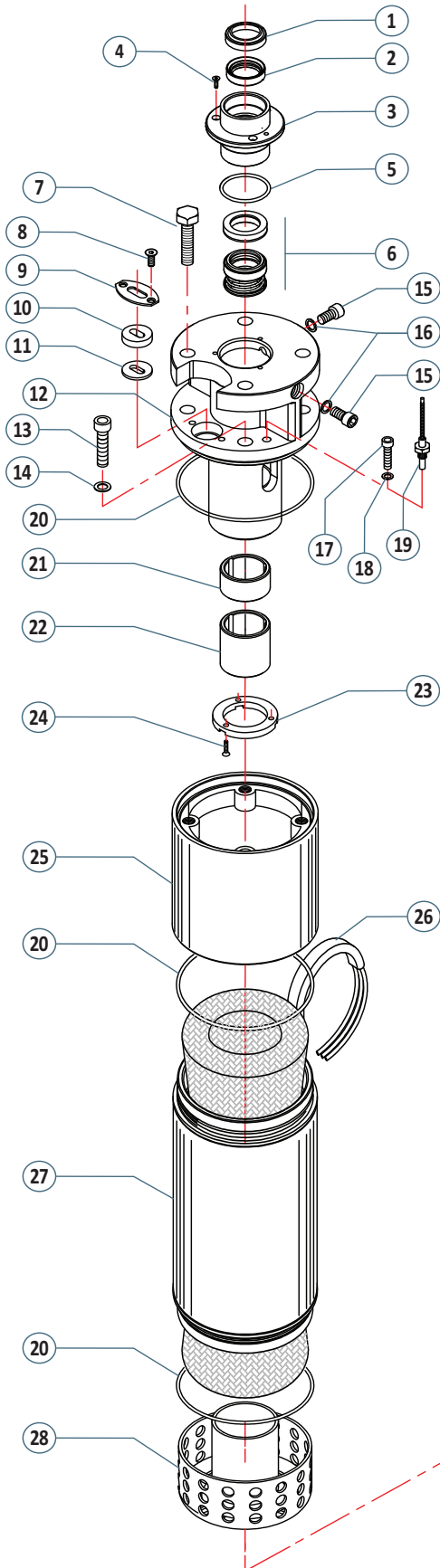

6" SERIES

Parts LIST with Material & Quantity

Pos.	Item Code	Part Name	Material	Qty	Unit
1	60101480	Wiper Seal	NBR + Stainless Steel	1	Nr
2	60101475	Lip Seal / Oil Seal	NBR + Stainless Steel	1	Nr
3	60101090	Seal Support KM6	Stainless Steel	1	Nr
4	60101075	Allen Bolt (Seal Support)	Stainless Steel	3	Nr
5	60101095	O.Ring (Seal Support)	NBR	1	Nr
6	60101080	Mechanical Seal	Silicon Tungsten Carbide (WC) + NBR + Stainless Steel	1	Nr
7	60101110	Hex Bolt ½ Inch X 1½ Inch 20TPI	Stainless Steel	4	Nr
8	60101077	Screw (Motor Lead)	Stainless Steel	2	Nr
9	601011XX	Cable Top Plate (Motor Lead)	Stainless Steel	1	Nr
10	601011XX	Gasket Rubber (Motor Lead)	NBR	1	Nr
11	601011XX	Cable Washer (Motor Lead)	Stainless Steel	1	Nr
12	60101005	Upper Support / Top Piece (Double Flange)	Cast Iron	1	Nr
13	60161245	Allen Bolt M12 X 45	Stainless Steel	4	Nr
14	60101156	Washer Bonded / Dowty Seal M12	NBR + Carbon Steel AISI 316	4	Nr
15	60101068	Allen Bolt (Top Piece)	Stainless Steel	2	Nr
16	60101157	Washer Bonded / Dowty Seal M10	NBR + Stainless Steel AISI 316	6	Nr
17	60161250	Allen Bolt M8 X 20	Stainless Steel	1	Nr
18	60161267	Washer Bonded / Dowty Seal M8	NBR/Stainless Steel AISI 316	1	Nr
19	60101485	PT100 Sensor (Optional)		1	Nr
20	60101065	O. Ring 3500	NBR	3	Nr
21	60101058	Carbon Bush Small (Lower & Upper)	Carbon	2	Nr
22	60101055	Carbon Bush Large (Lower & Upper)	Carbon	2	Nr
23	60101087	Upper Thrust Bearing	Brass	1	Nr
24	60101142	Screw (Upper Thrust) CSK M4X10	Stainless Steel	3	Nr
25	60101010	Upper Bearing Housing	Cast Iron	1	Nr
26A	601011XX	Motor Lead Cable (3 x 6 mm ² / 3 x 10 mm ²)	Copper + PVC	13	Ft
26B	601011XX	Motor Lead Cable (1 x 16 mm ²)	Copper + Rubber	13	Ft
26C	60101197	Cable for Earth 1 x 12 mm ²	Copper + PVC	13	Ft
27	601013XX	Stator Stack (Assembly)	Silicon Steel (M800-50A) + SS304	1	Set
28	60101202	Winding Protection Cover (Lower)	LDPE	1	Nr
29	601063XX	Rotor Shaft	Stainless Steel (SS431)	1	Nr
30	60101350	Rotor Lamination (Assembly)	Silicon Steel (M800-50A)	1	Set
31	60101145	Key for Rotor Shaft	Stainless Steel	1	Nr
32	60101013	Lower Bearing Housing	Cast Iron	1	Nr
33	60101212	Gasket	Tesnit	1	Nr
34	601010XX	Thrust Bearing	Stainless Steel + Carbon	1	Nr
35	60101018	Thrust Support	Cast Iron	1	Nr
36	60101030	Adjustment Bolt (Thrust Bearing)	Stainless Steel	1	Nr
37	60161010	Lock Washer Adj. Bolt	Mild Steel	1	Nr
38	60161252	Bolt Allen M6 x 20	Stainless Steel	2	Nr
39	60101071	Bolt Allen M10x170	Stainless Steel AISI 304	4	Nr
40	60101045	Diaphragm Rubber	NBR	1	Nr
41	6017061020	Thrust Extender	Cast Iron	1	Nr
42	60101143	Allen Bolt M8 x 25	Stainless Steel	4	Nr

Available Horse Power

From: 40 HP (30 kW)
To: 200 HP (150 kW)

Available Voltages

230 Volts - 60 Hertz
460 Volts - 60 Hertz
380 Volts - 50 Hertz

Available Speed

2-Pole

Available Insulation Class

Standard: Y

Available Materials Of Construction

Standard: Cast Iron Ends with
NSF Certified Epoxy
Optional: Complete 316L SS



DOUBLE FLANGE 8-INCH BOREHOLE SUBMERSIBLE ELECTRIC REWINDABLE MOTOR 8SME

8" SERIES

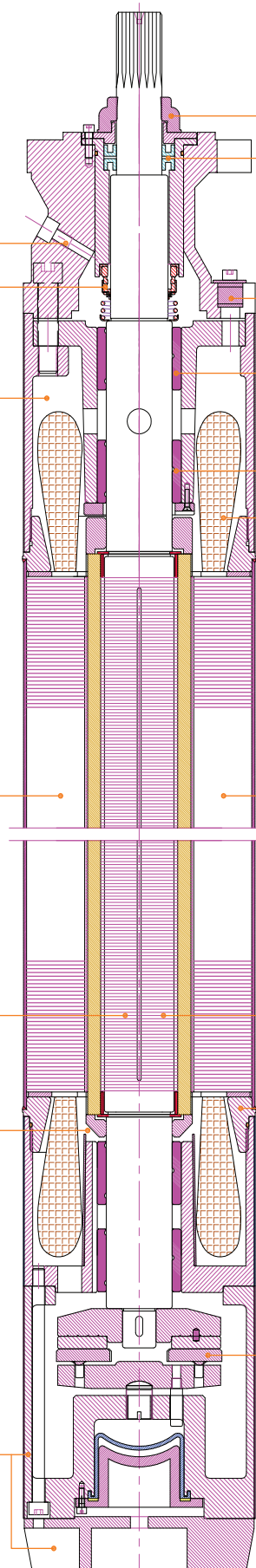

- Slanted water filling holes.
- Easily accessible, even with the coupled pump.
- Optimum location along with slanted design ensures maximum fluid level inside the motor.

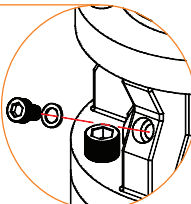

- Highly resistive to fine and coarse sand particles, thus ensuring safe operations in Sandy Wells.
- Ensures perfect sealing in extreme working conditions.
- High Grade Spring Loaded Mechanical Seal made of Tungsten Carbide.

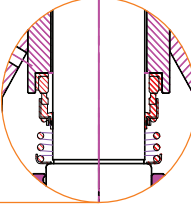

- Provision for installation of PT100 temperature sensor for real time motor temperature monitoring.
- Ensures added protection in special applications.

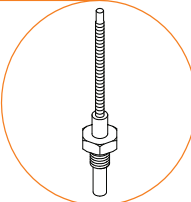

- Stator made of high grade silicon steel sheet.
- Low core losses, higher efficiency, lower ampere consumption and lower heat generation.
- High grade silicon steel sheet offers greater efficiency and reliability.

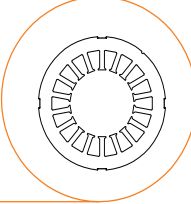

- Rotor is made of high grade silicon steel sheet with low losses.
- Pure copper bar inserted in the rotor slots.
- High efficiency and longer service life.

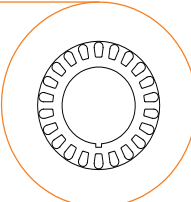

- Lower portion with double carbon bearings gives greater stability and vibration free operation of motor.
- Tapered design of balancing ring helps guide fluid into the carbon bearings ensuring water passage for better lubrication and heat dissipation.

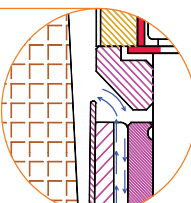

- Robust and oversized lower support fitted with tapered bottom cover, gives stable foundation to the motor.
- More space to easily accommodate larger thrust bearings.
- More space allows more coolant water for better heat dissipation.

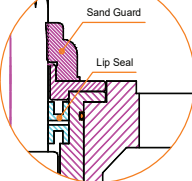
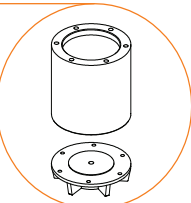

- SME Sealing has 3 layers of Protection
- Sand Guard resists sand, clay and mud against entering the Seal support, while remaining intact at 3500 RPM
- Lip/ Oil Seal resist fine sand against entering to Mechanical Seal.
- And finally, Mechanical Seal - Sealing it perfectly!

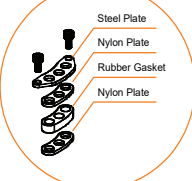

- Fully independent and robust cable sealing, rubber gasket sandwiched in nylon plates and finally tightened by steel plate through M8 Bolts
- Lead cable coming out of lower flange, minimize the chance of damage during assembly and installation.

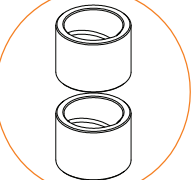

- Upper portion with double carbon bearings gives greater stability and vibration free operation of motor.
- Helps avoid damage to motor internals even in extreme applications.



- Pure copper winding wire with BOPET+ BOPP Insulation for higher temperature and better insulation as compared to PE2/PA Insulation.
- Mechanized coil insertion to maintain quality and precision.
- Over sized wire gauge to ensure longer service life and higher efficiency.

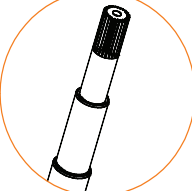

- High grade Stainless Steel Shaft, hardened to 40 HRC.
- Integral/ Single Piece Design ensure better stiffness and dimensional accuracy.
- Fully machined and grinded through out length.

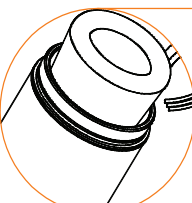

- Stator upper and lower ends are welded with threaded flange.
- Allows more dimensional accuracy due to independent machine-ability.
- Provide better structural integrity, serviceability and vibration free operation.

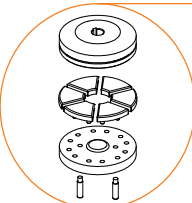

- Robust kingsbury type thrust bearing made of high grade material (Stainless Steel 400 Series) with finest workmanship.
- Water lubricated, low friction and highly durable.
- Customized thrust ratings available on client's demand.

✓ Key Features

8SME 8" submersible motors have been designed and produced according to the market's requirements. During the design and material selection phase, all efforts were made to offer an energy efficient product which stands for reliability, excellent quality, and long trouble free life.

The newly enhanced 8SME series of 8" submersible motors is specifically engineered for compatibility with VFD (Variable Frequency Drive) outputs, making it an ideal choice for solar-powered and other high-efficiency applications.

These 8" water-filled submersible motors have asynchronous three phase rewindable stator and a robust squirrel cage rotor.

- Wet Stator Design
- High Grade Material
- Easy Maintenance
- Long Service Life
- High Thermal Capacity
- High Efficiency
- Re-windable
- Eco Friendly
- NSF and ISO Certified
- Industrial, Commercial, Agriculture and Oil & Gas Application

⚙️ Technical Specification

Degree of protection	IP68
Insulation class	Y*
Working temperature	122 °F
Voltage tolerance	+ 6% / - 10%
Mounting position	Vertical/Horizontal
Min./Max. flow rate speed	0.5-12 ft/sec
Max. immersion depth	650 feet
Max. starts per hour	15
Packing	wooden crate

* Higher insulation wire class available.

☰ Specificaions

Winding:

Electrolytic Solid Copper wire wrapped in BOPP+ BOPET Insulation rated for temperatures over 100°C (212 °F) that allows more copper in the current slots. This technology allows the motor to run much cooler and achieve higher than normal horsepower ratings in standard frame sizes.

Stator:

All motors include an increased Stator stack length and combined M800 low-loss electrical magnetic sheet for a cooler running motor.

Rotor:

Increased stack length with M800 low-loss electrical magnetic sheet assembled and designed with newest technology and high grade copper bars.

Spline Shaft:

AISI 400 series stainless steel induction hardened & ground to operate in severe conditions. Dimensions according to international 8" NEMA standards.

Shaft Bearings:

Dual Water lubricated guide bearings made of high grade carbon, are fixed in upper and lower brackets for optimal operation in sandy wells and pump vibration control.

Thrust Bearings:

All SME submersible motors have Kingsbury type thrust bearing. The thrust assembly consists of a high quality carbon disc with hardened stainless steel shoes to handle necessary pump thrust loads. Available with axial load capacity of 18000 Lbs.

Seal Configuration:

SME offers a triple seal configuration that consists of two outer back to back lip seals in NBR with an inner Silicon Tungsten Carbide Seal for optimum protection in sandy wells.

Pressure Equalizing System:

Pressure compensation is managed by using a suitably sized NBR bellow to allow for expansion of the internal water as it heats up - or - from external pressure due to the depth of submergence.

Bearing Housings:

High resistance cast iron upper & lower bearing housing with NSF certified epoxy coating.

Filler Fluid:

Water mixed with NSF compliant Mono Propylene Glycol / Glycerin for optimal cooling, lubrication and corrosion resistance.

Note: All specifications are subject to change without any prior notice.

Electrical DATA

Electrical Data @ 60 Hz - Three Phase - 2 Poles

	Motor Type	Motor Size		Thrust Load (lbs)	RPM	Full Load Current (Amps)	S.F Load Current (Amps)	Starting Current (Amps)	KVA Code	Cos. Φ at Full Load	Efficiency at Full Load (%)	Service Factor
		HP	kW									
230V	8SME 0400-2	40	30	18000	3485	110.5	125.2	669	H	0.82	82.8	1.15
	8SME 0500-2	50	37	18000	3485	136.4	153.9	835	H	0.82	83.3	1.15
	8SME 0600-2	60	45	18000	3485	162.2	183.7	1081	J	0.82	84.1	1.15
460V	8SME 0400-2	40	30	18000	3495	54.2	61.3	328	H	0.83	83.6	1.15
	8SME 0500-2	50	37	18000	3495	66.9	75.4	409	H	0.83	84.1	1.15
	8SME 0600-2	60	45	18000	3495	79.5	90.5	533	H	0.83	84.9	1.15
	8SME 0750-2	75	56	18000	3485	95.2	108.7	655	H	0.85	86.9	1.15
	8SME 1000-2	100	75	18000	3490	126.6	144.0	940	J	0.85	86.7	1.15
	8SME 1250-2	125	93	18000	3485	157.0	179.2	1232	J	0.86	87.0	1.15
	8SME 1500-2	150	112	18000	3490	186.1	213.7	1496	J	0.86	87.3	1.15
	8SME 1750-2	175	130	18000	3490	221.5	253.0	1801	K	0.84	88.0	1.15
	8SME 2000-2	200	150	18000	3485	246.8	281.1	2024	K	0.85	89.2	1.15

8" 60 HZ SERIES

Technical DETAILS

Size & Dimensions Motor Leads @ 60 Hz - 230/460 Volt

Sr. No.	Volt	Motor Size		Lead Size			Dimension Dia (inch)	Cable Length (Feet)	Qty (Nr.)	
		HP	kW	Core	mm ²	AWG				
DOL	1	230V	40 ~ 50	30 ~ 37	1	25	4	0.53	16	3
	2	230V	60	45	1	35	2	0.59	16	3
	3	460V	40 ~ 50	30 ~ 37	1	12/16	6	0.27/0.45	16	3
	4	460V	60 ~ 75	45 ~ 56	1	16	6	0.45	16	3
	5	460V	100	75	1	25	4	0.53	16	3
	6	460V	125 ~ 150	93 ~ 110	1	35	2	0.59	16	3
	7	460V	175 ~ 200	130 ~ 150	1	50	1	0.68	16	3
SD	8	460V	40 ~ 125	30 ~ 93	1	16	6	0.45	16	6
	9	460V	150 ~ 200	110 ~ 150	1	25	4	0.53	16	6

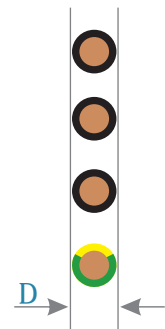

Additional core 1 x 12 mm² 16 feet for earthing.

Motor Performance Curve

tolerances according to NEMA standard and IEC 60034-1

40 HP | **29.8** kW | **230** Volt | **60** Hertz | **2** Pole

8" 60 HZ SERIES

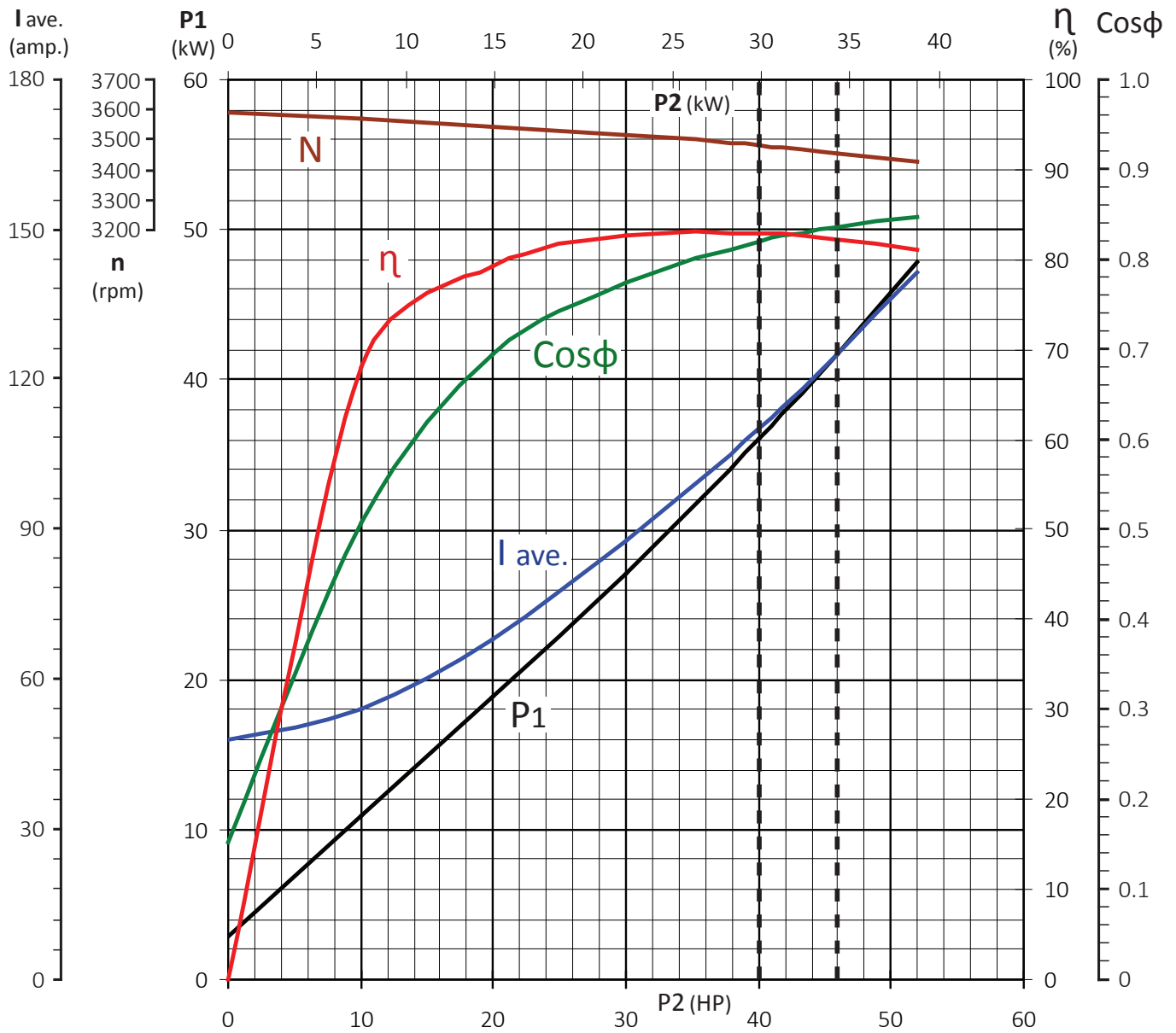

Load	Frequency Hz	Volt ave. V	I ave. A	P1 kW	P1 HP	RPM	Torque Nm	P2 kW	P2 HP	Efficiency %	Cos pi
0%	60.00	230.0	48.06	2.93	3.93	3593.5	0.00	0.00	0.00	0.00%	0.153
25%	60.00	230.0	54.04	10.94	14.66	3570.5	19.95	7.46	10.00	68.22%	0.508
50%	60.00	230.0	68.16	18.84	25.26	3545.7	40.18	14.92	20.00	79.17%	0.694
75%	60.00	230.0	87.61	27.05	36.26	3516.9	60.77	22.38	30.00	82.75%	0.775
100%	60.00	230.0	110.46	36.04	48.31	3484.7	81.77	29.84	40.00	82.80%	0.819
115%	60.00	230.0	125.23	41.75	55.97	3454.1	94.87	34.32	46.00	82.19%	0.837
130%	60.00	230.0	141.65	47.85	64.15	3428.2	108.05	38.79	52.00	81.07%	0.848

Motor Performance Curve

tolerances according to NEMA standard and IEC 60034-1

50 HP | **37.3** kW | **230** Volt | **60** Hertz | **2** Pole

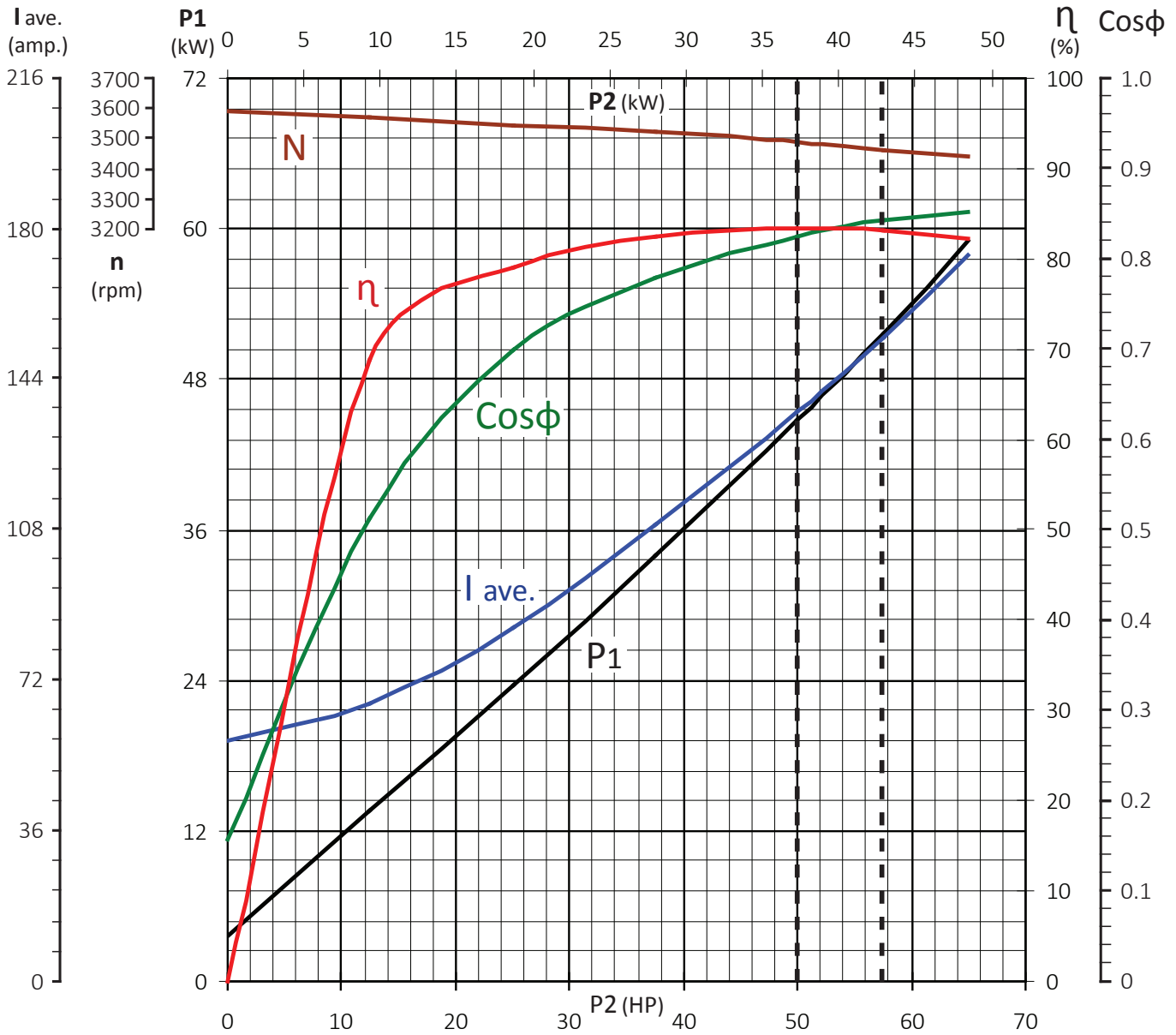

8" 60 HZ SERIES

Load	Frequency Hz	Volt ave. V	I ave. A	P1 kW	P1 HP	RPM	Torque Nm	P2 kW	P2 HP	Efficiency %	Cos pi
0%	60.00	230.0	57.76	3.64	4.87	3593.7	0.00	0.00	0.00	0.00%	0.158
25%	60.00	230.0	66.27	13.54	18.15	3570.0	24.94	9.33	12.50	68.86%	0.513
50%	60.00	230.0	84.75	23.60	31.63	3545.2	50.23	18.65	25.00	79.03%	0.699
75%	60.00	230.0	109.07	33.89	45.43	3519.6	75.90	27.98	37.50	82.55%	0.780
100%	60.00	230.0	136.43	44.78	60.03	3485.1	102.20	37.30	50.00	83.29%	0.824
115%	60.00	230.0	153.91	51.62	69.20	3462.7	118.29	42.90	57.50	83.09%	0.842
130%	60.00	230.0	173.70	59.02	79.12	3440.3	134.59	48.49	65.00	82.15%	0.853

Motor Performance Curve

tolerances according to NEMA standard and IEC 60034-1

60 HP | **44.8** kW | **230** Volt | **60** Hertz | **2** Pole

8" 60 HZ SERIES

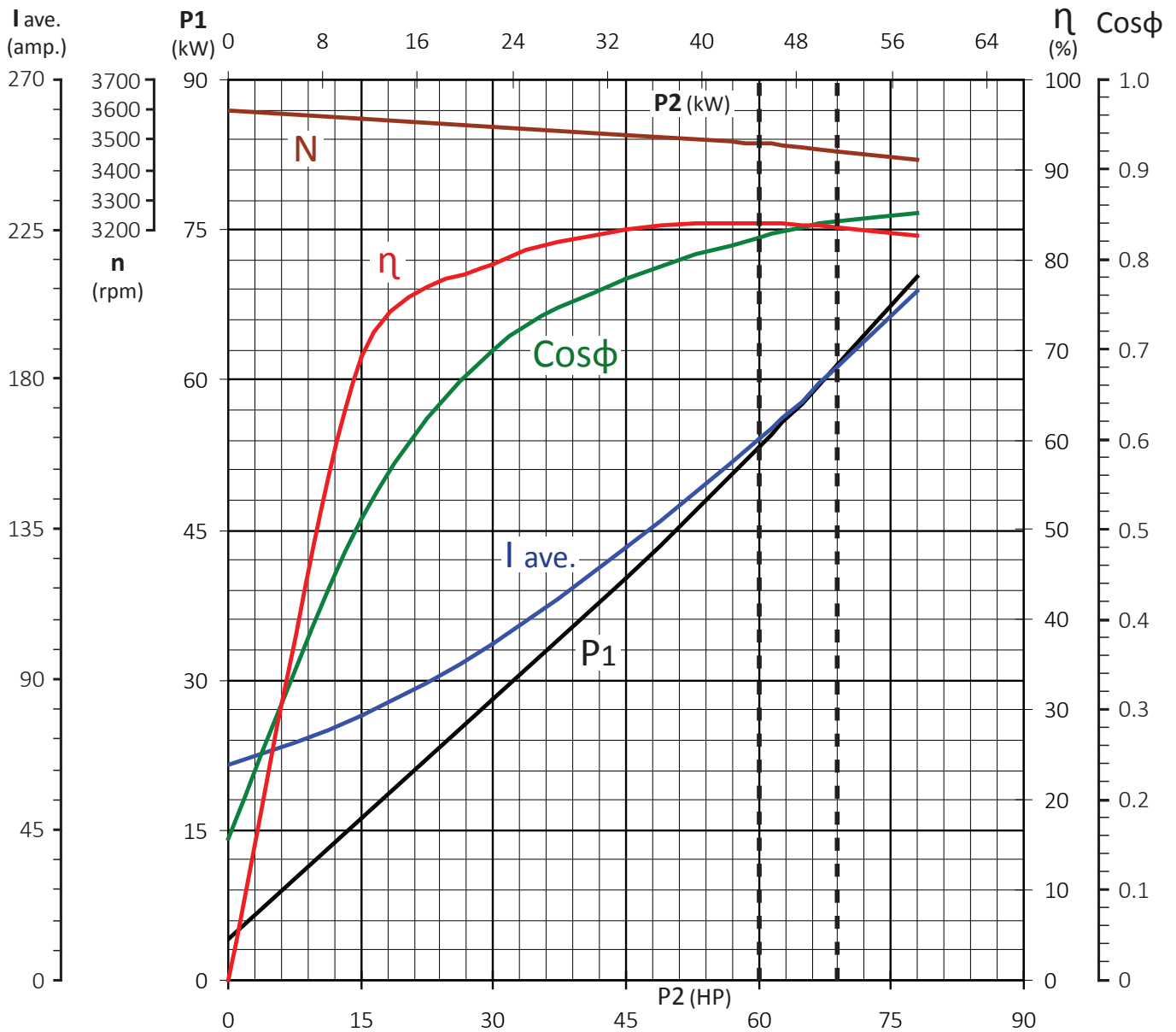

Load	Frequency Hz	Volt ave. V	I ave. A	P1 kW	P1 HP	RPM	Torque Nm	P2 kW	P2 HP	Efficiency %	Cos pi
0%	60.00	230.0	64.76	4.08	5.46	3594.9	0.00	0.00	0.00	0.00%	0.158
25%	60.00	230.0	79.08	16.16	21.66	3570.1	29.93	11.19	15.00	69.24%	0.513
50%	60.00	230.0	100.98	28.12	37.69	3545.8	60.27	22.38	30.00	79.59%	0.699
75%	60.00	230.0	129.59	40.27	53.98	3516.7	91.16	33.57	45.00	83.37%	0.780
100%	60.00	230.0	162.22	53.25	71.38	3485.0	122.65	44.76	60.00	84.06%	0.824
115%	60.00	230.0	183.66	61.60	82.58	3460.3	142.05	51.47	69.00	83.56%	0.842
130%	60.00	230.0	206.90	70.31	94.24	3435.6	161.73	58.19	78.00	82.76%	0.853

Motor Performance Curve

tolerances according to NEMA standard and IEC 60034-1

40 HP | **29.8** kW | **460** Volt | **60** Hertz | **2** Pole

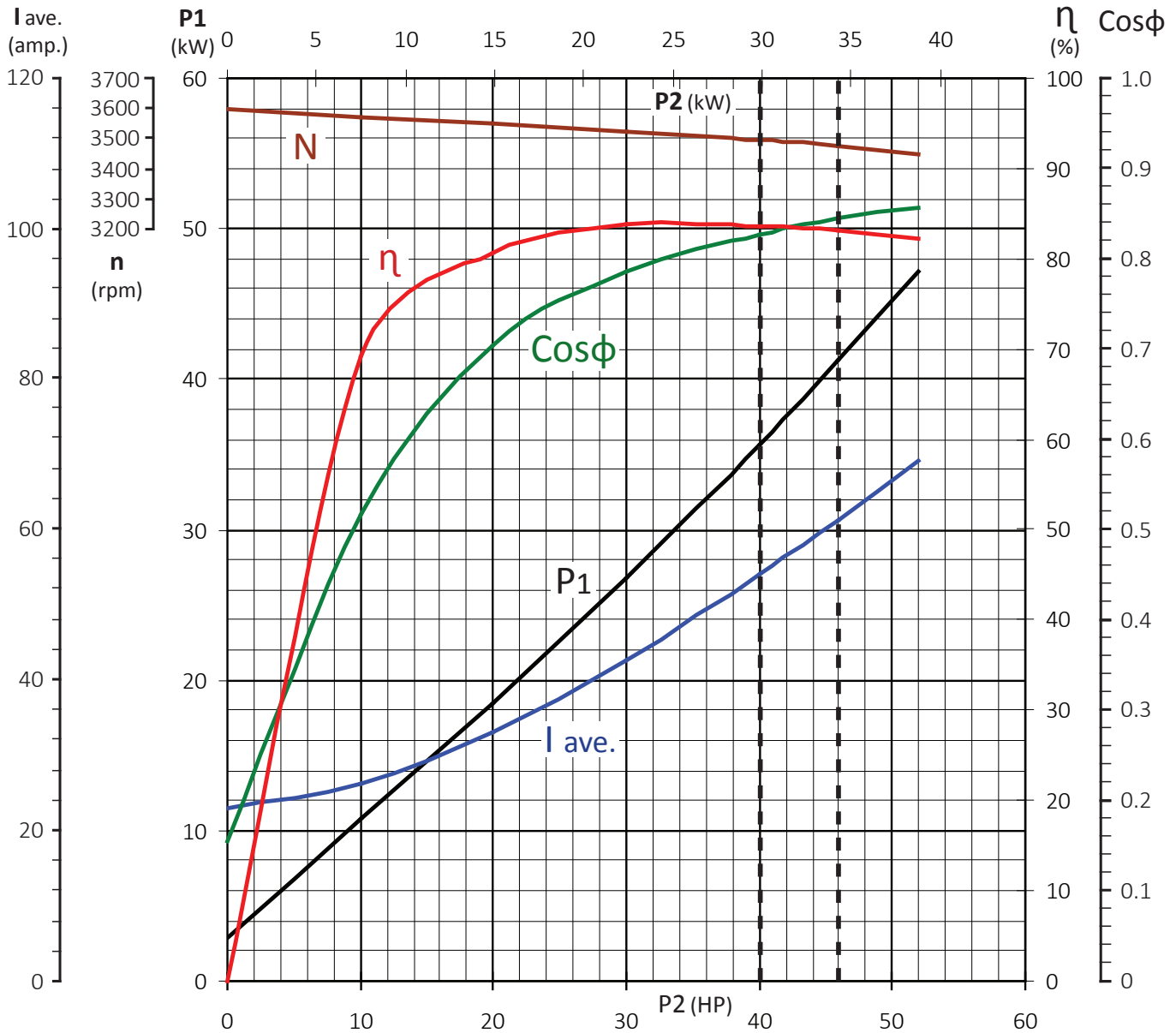

8" 60 HZ SERIES

Load	Frequency Hz	Volt ave. V	I ave. A	P1 kW	P1 HP	RPM	Torque Nm	P2 kW	P2 HP	Efficiency %	Cos pi
0%	60.00	460.0	23.01	2.86	3.83	3594.1	0.00	0.00	0.00	0.00%	0.156
25%	60.00	460.0	26.12	10.78	14.45	3573.1	19.94	7.46	10.00	69.20%	0.518
50%	60.00	460.0	32.95	18.51	24.81	3550.5	40.13	14.92	20.00	80.61%	0.705
75%	60.00	460.0	42.67	26.72	35.82	3524.2	60.64	22.38	30.00	83.76%	0.786
100%	60.00	460.0	54.15	35.68	47.83	3494.8	81.54	29.84	40.00	83.63%	0.827
115%	60.00	460.0	61.33	41.29	55.35	3472.2	94.38	34.32	46.00	83.11%	0.845
130%	60.00	460.0	69.09	47.12	63.16	3448.5	107.42	38.79	52.00	82.33%	0.856

Motor Performance Curve

tolerances according to NEMA standard and IEC 60034-1

50 HP | **37.3** kW | **460** Volt | **60** Hertz | **2** Pole

8" 60 HZ SERIES

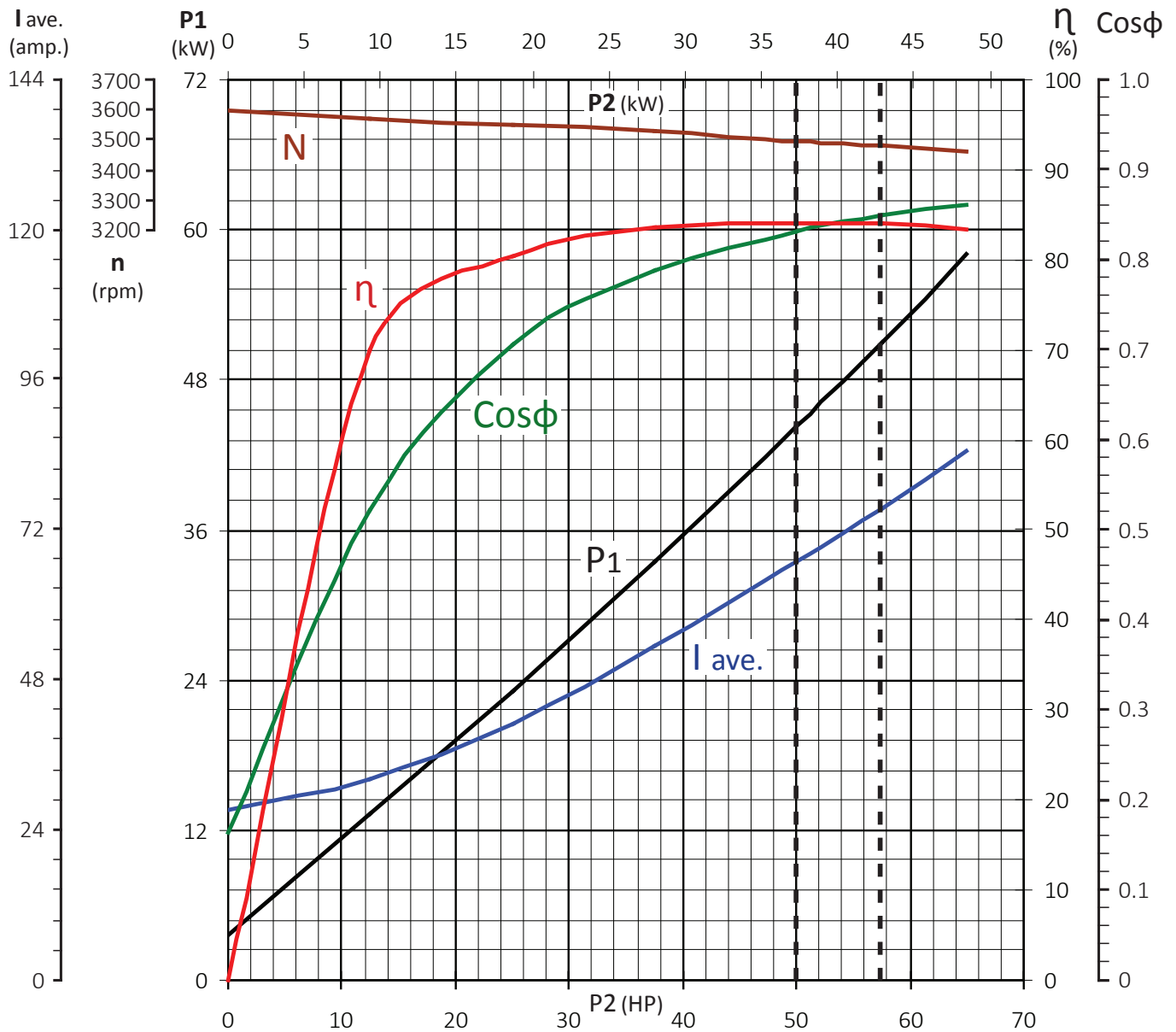

Load	Frequency Hz	Volt ave. V	I ave. A	P1 kW	P1 HP	RPM	Torque Nm	P2 kW	P2 HP	Efficiency %	Cos pi
0%	60.00	460.0	27.34	3.55	4.76	3594.4	0.00	0.00	0.00	0.00%	0.163
25%	60.00	460.0	32.16	13.35	17.90	3572.7	24.92	9.33	12.50	69.85%	0.521
50%	60.00	460.0	41.15	23.18	31.07	3550.2	50.16	18.65	25.00	80.46%	0.707
75%	60.00	460.0	53.33	33.48	44.88	3526.8	75.75	27.98	37.50	83.56%	0.788
100%	60.00	460.0	66.89	44.34	59.44	3495.4	101.90	37.30	50.00	84.12%	0.832
115%	60.00	460.0	75.38	51.05	68.43	3480.2	117.70	42.90	57.50	84.03%	0.850
130%	60.00	460.0	84.73	58.12	77.91	3459.7	133.84	48.49	65.00	83.43%	0.861

Motor Performance Curve

tolerances according to NEMA standard and IEC 60034-1

60 HP | **44.8** kW | **460** Volt | **60** Hertz | **2** Pole

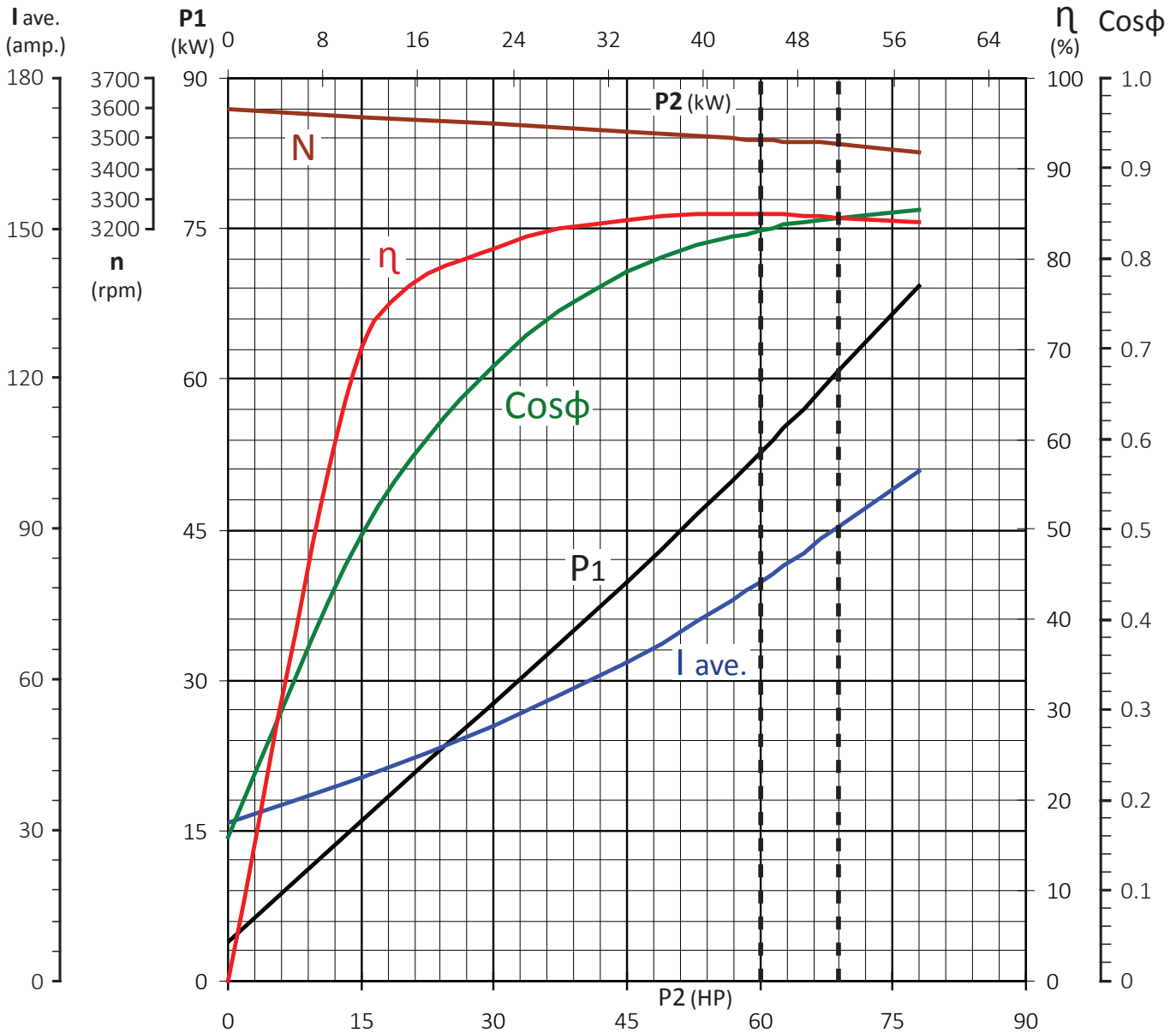

8" 60 HZ SERIES

Load	Frequency Hz	Volt ave. V	I ave. A	P1 kW	P1 HP	RPM	Torque Nm	P2 kW	P2 HP	Efficiency %	Cos pi
0%	60.00	460.0	31.42	3.98	5.34	3595.4	0.00	0.00	0.00	0.00%	0.159
25%	60.00	460.0	40.47	15.93	21.35	3572.9	29.91	11.19	15.00	70.24%	0.494
50%	60.00	460.0	50.91	27.62	37.02	3550.7	60.19	22.38	30.00	81.03%	0.681
75%	60.00	460.0	63.60	39.78	53.32	3524.1	90.96	33.57	45.00	84.39%	0.785
100%	60.00	460.0	79.53	52.72	70.67	3495.3	122.29	44.76	60.00	84.90%	0.832
115%	60.00	460.0	90.49	60.92	81.66	3478.0	141.33	51.47	69.00	84.49%	0.845
130%	60.00	460.0	101.63	69.23	92.80	3455.4	160.81	58.19	78.00	84.05%	0.855

Motor Performance Curve

tolerances according to NEMA standard and IEC 60034-1

75 HP | **56** kW | **460** Volt | **60** Hertz | **2** Pole

8" 60 HZ SERIES

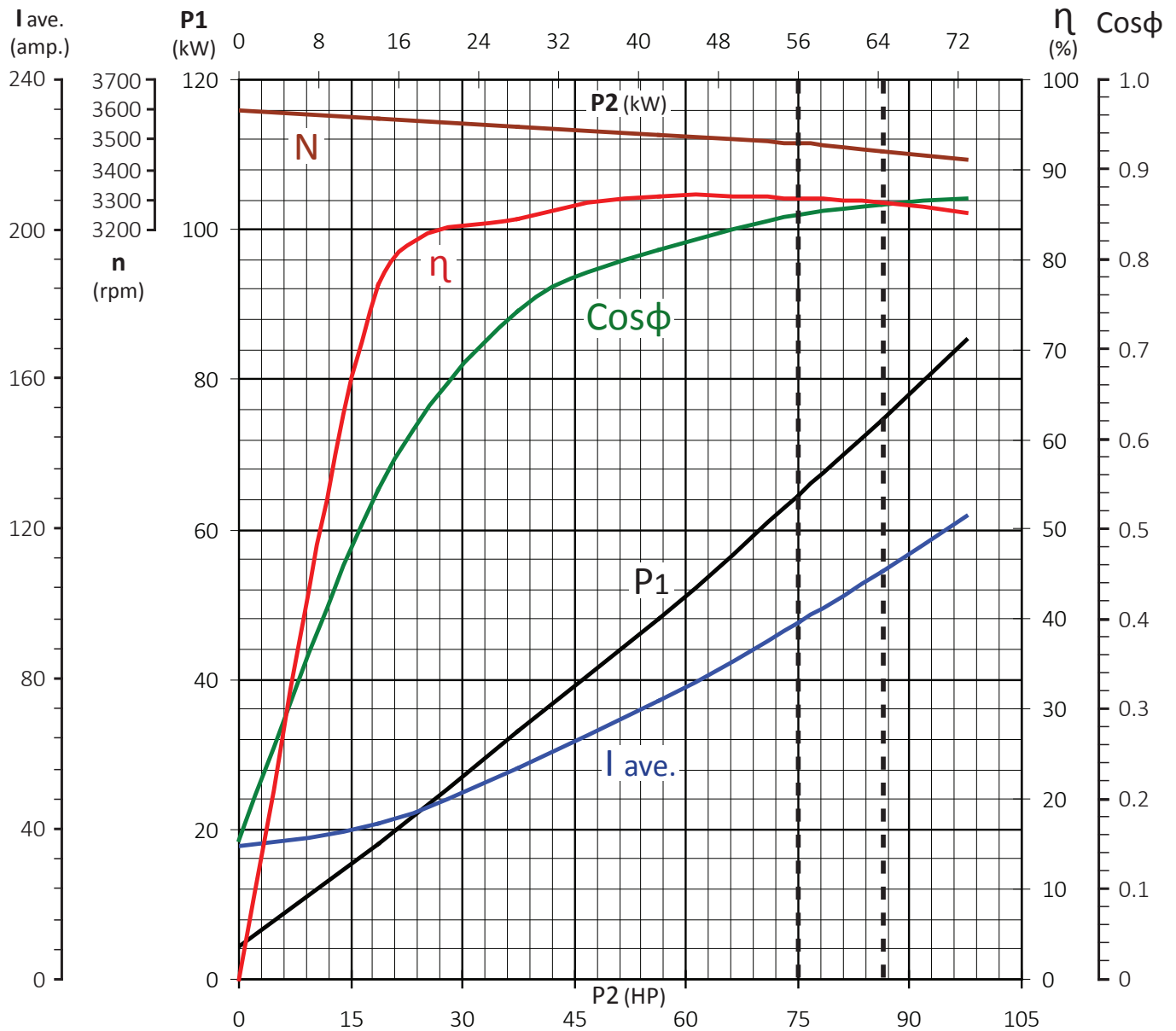

Load	Frequency Hz	Volt ave. V	I ave. A	P1 kW	P1 HP	RPM	Torque Nm	P2 kW	P2 HP	Efficiency %	Cos pi
0%	60.00	460.0	34.42	4.25	5.70	3595.2	0.00	0.00	0.00	0.00%	0.155
25%	60.00	460.0	41.81	18.12	24.29	3572.3	37.39	13.99	18.75	77.19%	0.544
50%	60.00	460.0	56.06	33.14	44.42	3545.5	75.35	27.98	37.50	84.41%	0.742
75%	60.00	460.0	74.55	48.23	64.65	3516.4	113.95	41.96	56.25	87.00%	0.812
100%	60.00	460.0	95.19	64.39	86.31	3484.8	153.32	55.95	75.00	86.89%	0.849
115%	60.00	460.0	108.72	74.58	99.97	3462.9	177.43	64.34	86.25	86.27%	0.861
130%	60.00	460.0	123.40	85.34	114.40	3435.8	202.15	72.74	97.50	85.23%	0.868

Motor Performance Curve

tolerances according to NEMA standard and IEC 60034-1

100 HP | **74.6** kW | **460** Volt | **60** Hertz | **2** Pole

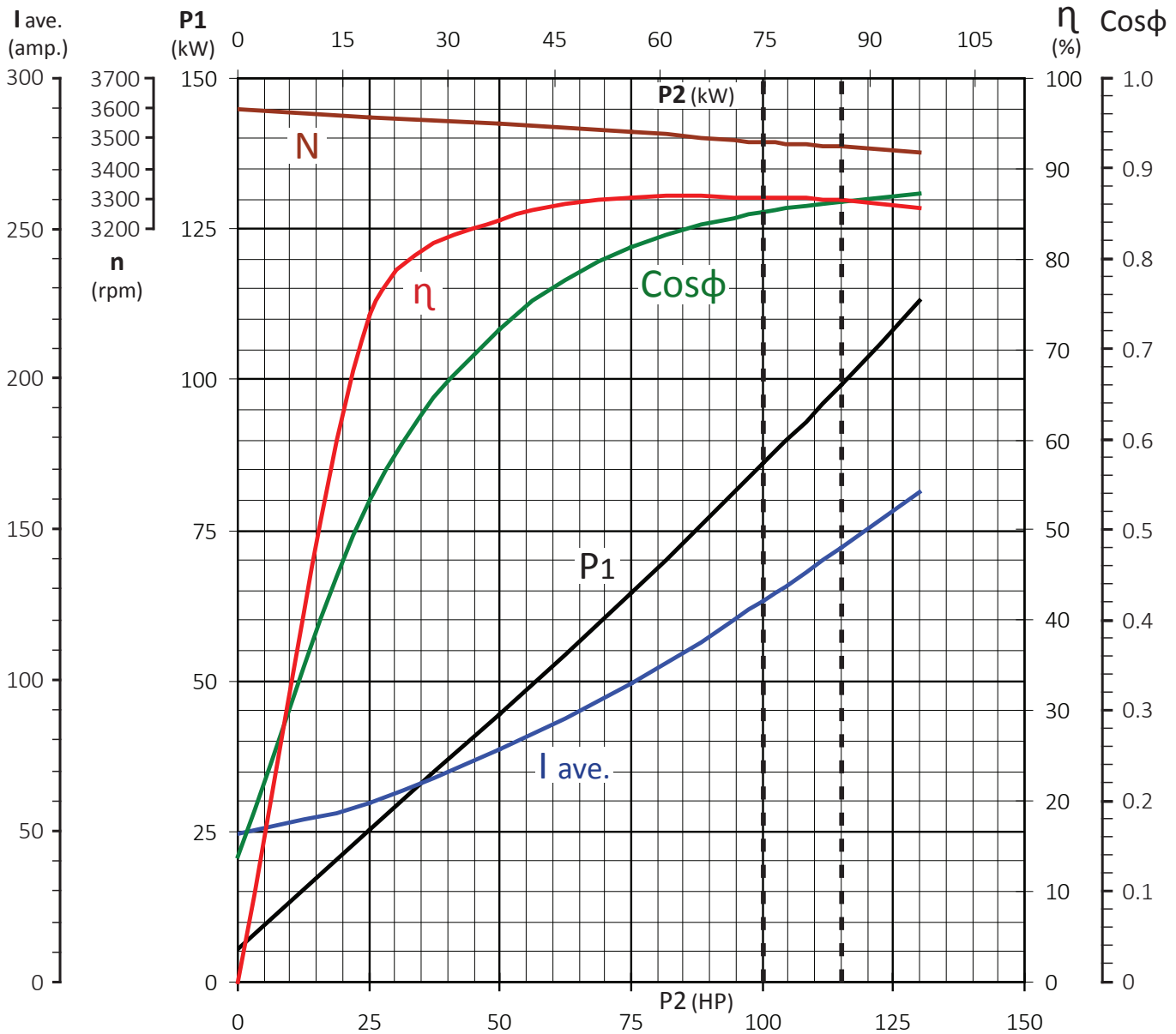

8" 60 HZ SERIES

Load	Frequency Hz	Volt ave. V	I ave. A	P1 kW	P1 HP	RPM	Torque Nm	P2 kW	P2 HP	Efficiency %	Cos pi
0%	60.00	460.0	49.30	5.42	7.27	3596.4	0.00	0.00	0.00	0.00%	0.138
25%	60.00	460.0	59.35	25.25	33.85	3573.5	49.84	18.65	25.00	73.86%	0.534
50%	60.00	460.0	77.12	44.30	59.38	3548.0	100.39	37.30	50.00	84.20%	0.721
75%	60.00	460.0	99.33	64.42	86.35	3524.3	151.60	55.95	75.00	86.85%	0.814
100%	60.00	460.0	126.62	86.05	115.35	3490.2	204.11	74.60	100.00	86.69%	0.853
115%	60.00	460.0	143.99	99.12	132.87	3474.9	235.76	85.79	115.00	86.55%	0.864
130%	60.00	460.0	162.80	113.23	151.78	3451.8	268.29	96.98	130.00	85.65%	0.873

Motor Performance Curve

tolerances according to NEMA standard and IEC 60034-1

125 HP | **93** kW | **460** Volt | **60** Hertz | **2** Pole

8" 60 HZ SERIES

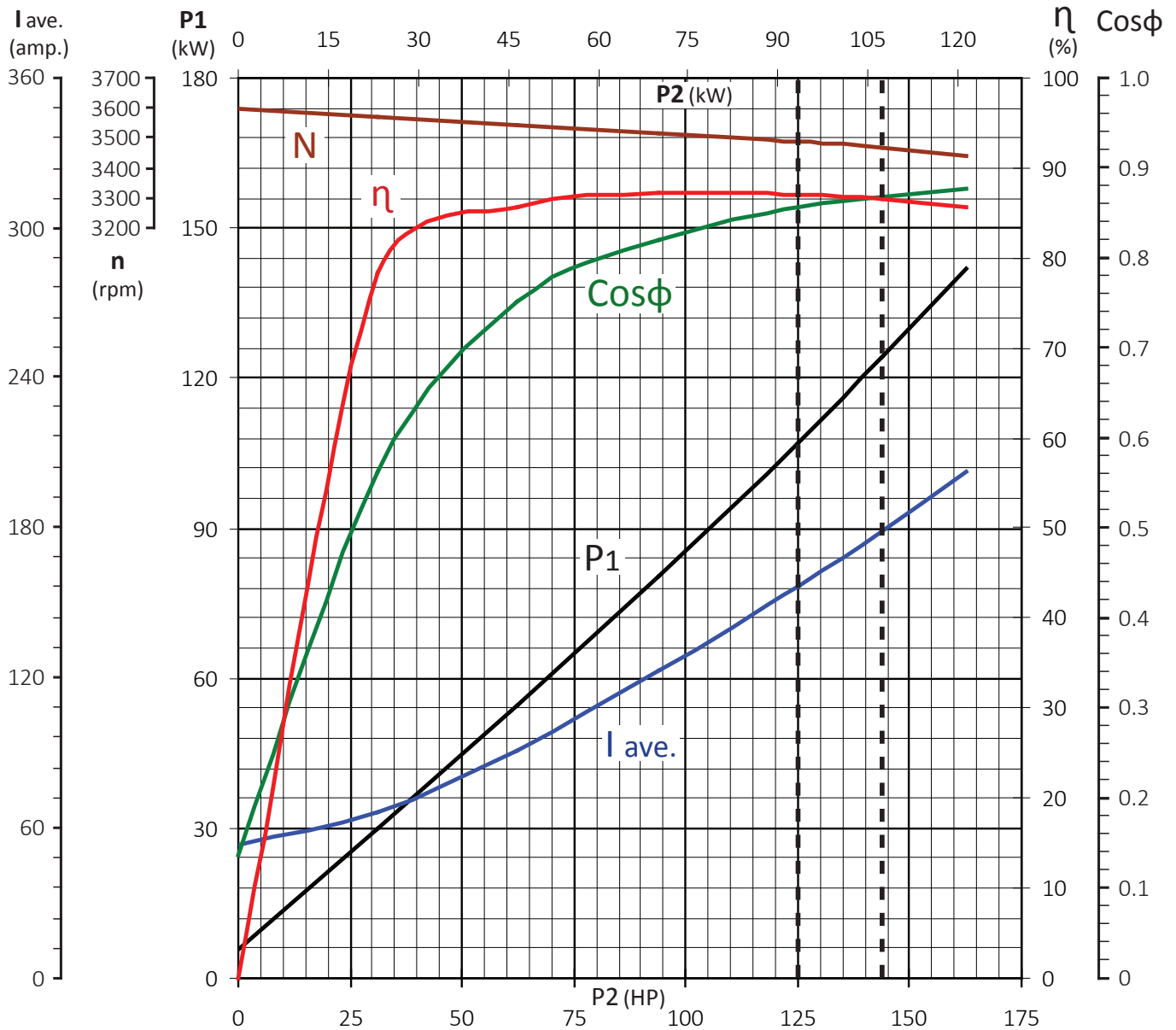

Load	Frequency Hz	Volt ave. V	I ave. A	P1 kW	P1 HP	RPM	Torque Nm	P2 kW	P2 HP	Efficiency %	Cos pi
0%	60.00	460.0	53.34	5.78	7.75	3597.3	0.00	0.00	0.00	0.00%	0.136
25%	60.00	460.0	66.39	29.78	39.92	3571.0	62.34	23.31	31.25	78.28%	0.563
50%	60.00	460.0	90.90	54.39	72.91	3546.0	125.56	46.63	62.50	85.72%	0.751
75%	60.00	460.0	122.94	80.22	107.53	3517.1	189.89	69.94	93.75	87.18%	0.819
100%	60.00	460.0	156.97	107.18	143.67	3485.3	255.49	93.25	125.00	87.00%	0.857
115%	60.00	460.0	179.17	124.05	166.29	3464.7	295.57	107.24	143.75	86.45%	0.869
130%	60.00	460.0	202.83	141.72	189.97	3439.4	336.58	121.23	162.50	85.54%	0.877

Motor Performance Curve

tolerances according to NEMA standard and IEC 60034-1

150 HP | **112** kW | **460** Volt | **60** Hertz | **2** Pole

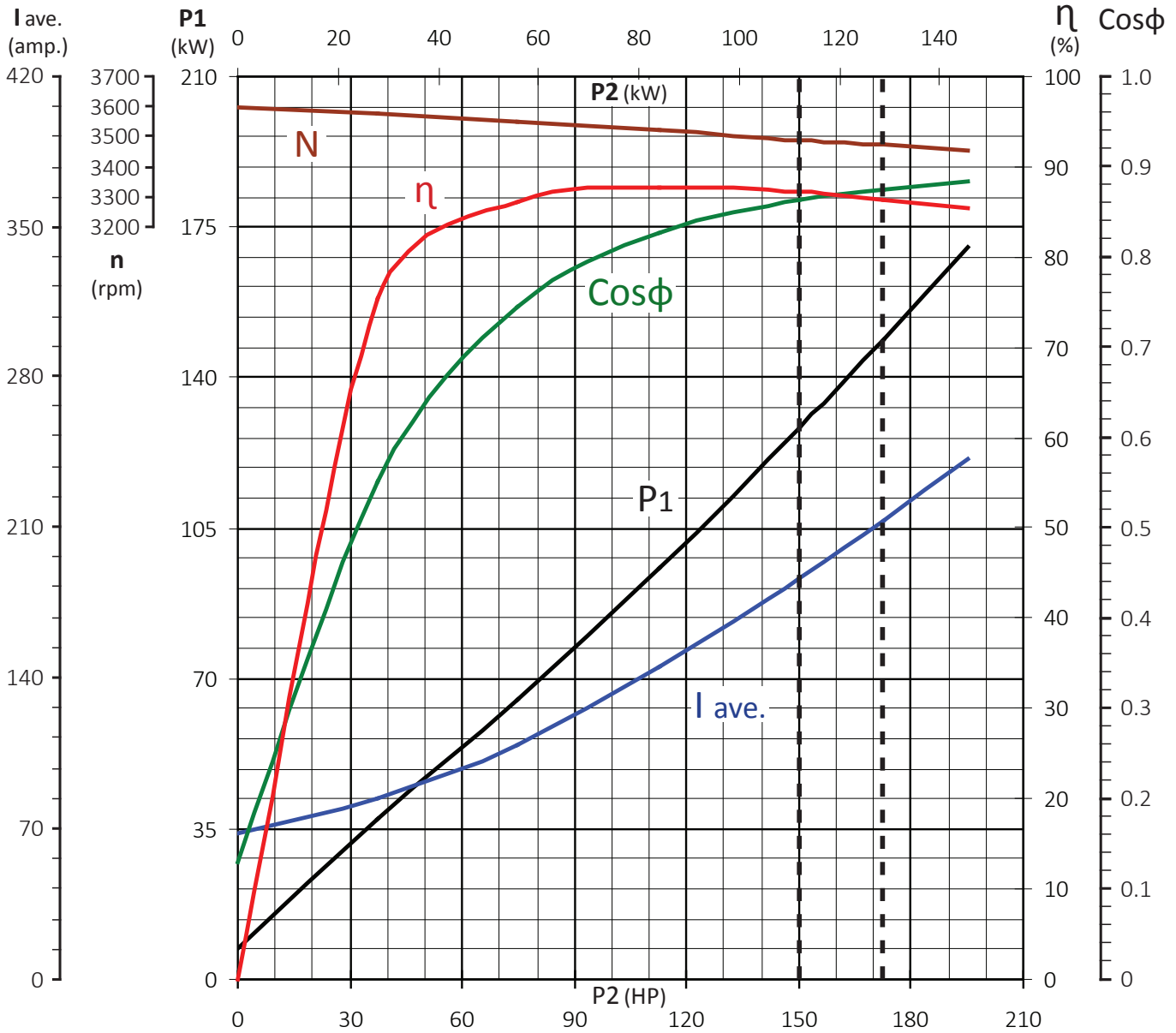

8" 60 HZ SERIES

Load	Frequency Hz	Volt ave. V	I ave. A	P1 kW	P1 HP	RPM	Torque Nm	P2 kW	P2 HP	Efficiency %	Cos pi
0%	60.00	460.0	67.78	7.02	9.41	3598.2	0.00	0.00	0.00	0.00%	0.130
25%	60.00	460.0	84.40	37.12	49.76	3575.5	74.72	27.98	37.50	75.36%	0.552
50%	60.00	460.0	109.26	64.94	87.05	3550.2	150.49	55.95	75.00	86.16%	0.746
75%	60.00	460.0	145.19	95.78	128.39	3522.7	227.50	83.93	112.50	87.62%	0.828
100%	60.00	460.0	186.12	128.12	171.74	3490.3	306.15	111.90	150.00	87.34%	0.864
115%	60.00	460.0	213.66	148.95	199.66	3471.5	353.98	128.69	172.50	86.39%	0.875
130%	60.00	460.0	242.33	170.48	228.53	3451.3	402.49	145.47	195.00	85.33%	0.883

Motor Performance Curve

tolerances according to NEMA standard and IEC 60034-1

175 HP | **131** kW | **460** Volt | **60** Hertz | **2** Pole

8" 60 HZ SERIES

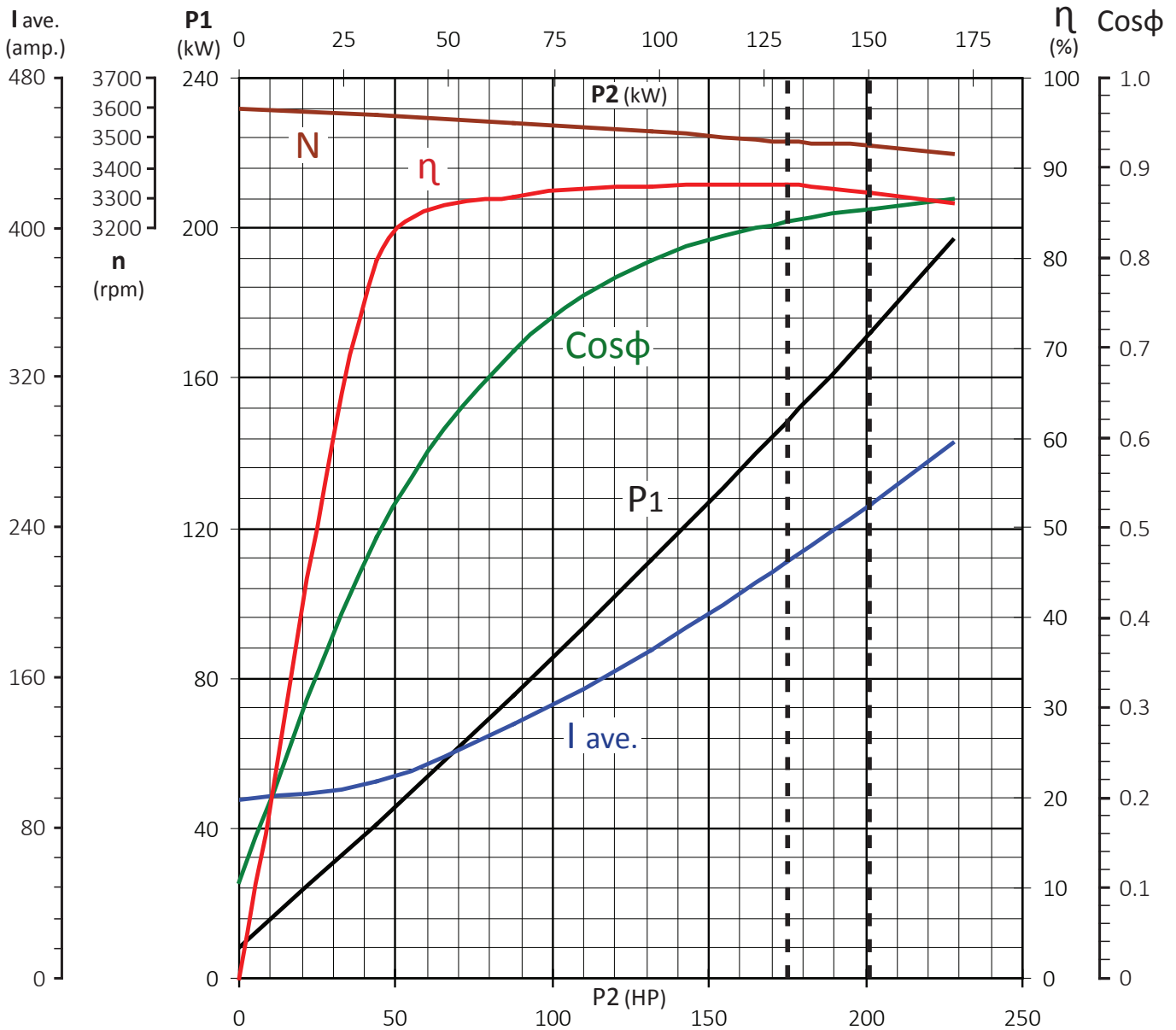

Load	Frequency Hz	Volt ave. V	I ave. A	P1 kW	P1 HP	RPM	Torque Nm	P2 kW	P2 HP	Efficiency %	Cos pi
0%	60.00	460.0	95.07	8.18	10.97	3598.8	0.00	0.00	0.00	0.00%	0.108
25%	60.00	460.0	104.82	40.92	54.85	3579.2	87.08	32.64	43.75	79.76%	0.490
50%	60.00	460.0	135.51	75.25	100.87	3549.8	175.60	65.28	87.50	86.74%	0.697
75%	60.00	460.0	175.36	111.35	149.26	3522.7	265.42	97.91	131.25	87.93%	0.797
100%	60.00	460.0	221.55	148.27	198.75	3490.2	357.18	130.55	175.00	88.05%	0.840
115%	60.00	460.0	252.97	172.12	230.72	3472.4	412.87	150.13	201.25	87.23%	0.854
130%	60.00	460.0	285.60	197.05	264.14	3449.4	469.84	169.72	227.50	86.13%	0.866

Motor Performance Curve

tolerances according to NEMA standard and IEC 60034-1

200 HP | **150** kW | **460** Volt | **50** Hertz | **2** Pole

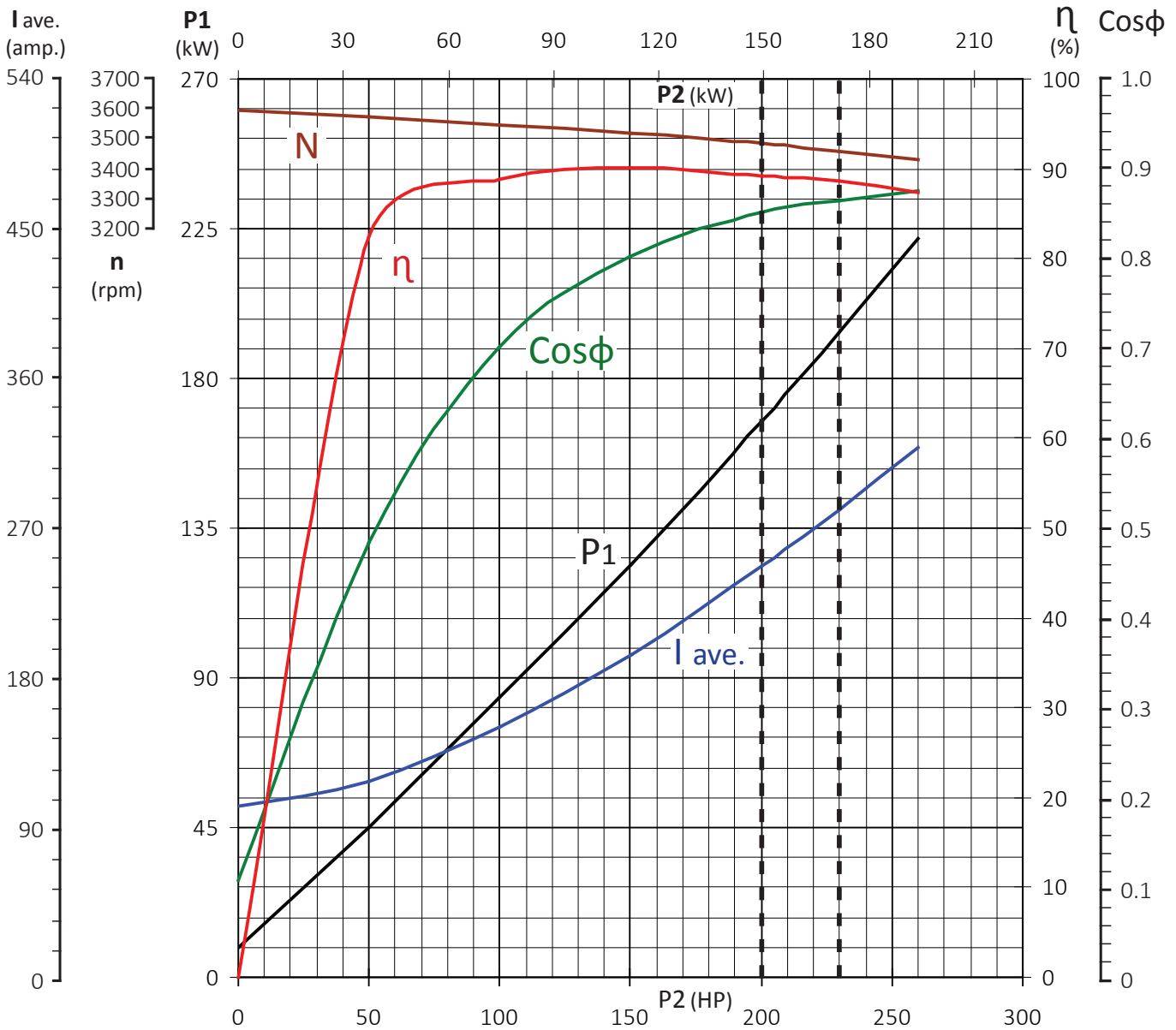

8" 60 HZ SERIES

Load	Frequency Hz	Volt ave. V	I ave. A	P1 kW	P1 HP	RPM	Torque Nm	P2 kW	P2 HP	Efficiency %	Cos pi
0%	60.00	460.0	103.20	8.88	11.90	3597.5	0.00	0.00	0.00	0.00%	0.108
25%	60.00	460.0	117.54	45.23	60.63	3574.6	99.64	37.30	50.00	82.47%	0.483
50%	60.00	460.0	150.17	83.99	112.59	3545.8	200.91	74.60	100.00	88.82%	0.702
75%	60.00	460.0	194.25	124.12	166.38	3518.2	303.73	111.90	150.00	90.15%	0.802
100%	60.00	460.0	246.77	167.31	224.28	3484.8	408.85	149.20	200.00	89.18%	0.851
115%	60.00	460.0	281.09	193.72	259.68	3458.3	473.77	171.58	230.00	88.57%	0.865
130%	60.00	460.0	318.29	222.14	297.77	3431.9	539.70	193.96	260.00	87.31%	0.876

Electrical DATA

Electrical Data @ 50 Hz - Three Phase - 380 Volt										
Motor Type	Motor Size		Thrust Load (lbs)	RPM	Full Load Current (Amps)	Starting Current (Amps)	KVA Code	Cos. Φ at Full Load	Efficiency at Full Load (%)	Service Factor
	HP	kW								
8SME 0400-2	40	30	18000	2880	64.5	345	G	0.85	82.8	1
8SME 0500-2	50	37	18000	2875	79.7	432	G	0.86	82.9	1
8SME 0600-2	60	45	18000	2875	95.1	560	G	0.85	84.3	1
8SME 0750-2	75	56	18000	2855	116.1	700	G	0.86	84.9	1
8SME 1000-2	100	75	18000	2860	155.4	1015	H	0.86	84.6	1
8SME 1250-2	125	93	18000	2855	191.2	1315	H	0.87	85.0	1
8SME 1500-2	150	112	18000	2860	228.3	1598	H	0.87	85.4	1
8SME 1750-2	175	130	18000	2860	266.6	1898	J	0.86	86.3	1
8SME 2000-2	200	150	18000	2850	301.4	2170	J	0.88	85.7	1

8" 50 HZ SERIES

2 - POLE

Technical DETAILS

Size & Dimensions Motor Leads @ 50 Hz - 380 Volt								
Sr: No.	2 - POLE Motor Size		Lead Size			Dimension Dia (inch)	Cable Length (Feet)	Qty (Nr.)
	HP	kW	Core	mm ²	AWG			
1	40 ~ 50	30 ~ 37	1	12/16	6	0.27/0.45	16	3
2	60 ~ 75	45 ~ 56	1	16	6	0.45	16	3
3	100	75	1	25	4	0.53	16	3
4	125	93	1	35	2	0.59	16	3
5	150 ~ 175	112 ~ 130	1	50	1	0.68	16	3
6	200	150	1	70	2/0	0.77	16	3

SD	5	40 ~ 125	30 ~ 93	1	16	6	0.45	16	6
	6	150 ~ 175	112 ~ 130	1	25	4	0.53	16	6
	7	150 ~ 175	112 ~ 130	1	35	2	0.59	16	6

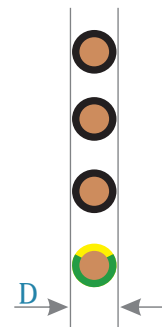

Additional core 1 x 12 mm² 16 feet for earthing.

Motor Performance Curve

tolerances according to NEMA standard and IEC 60034-1

40 HP | **29.8** kW | **380** Volt | **50** Hertz | **2** Pole

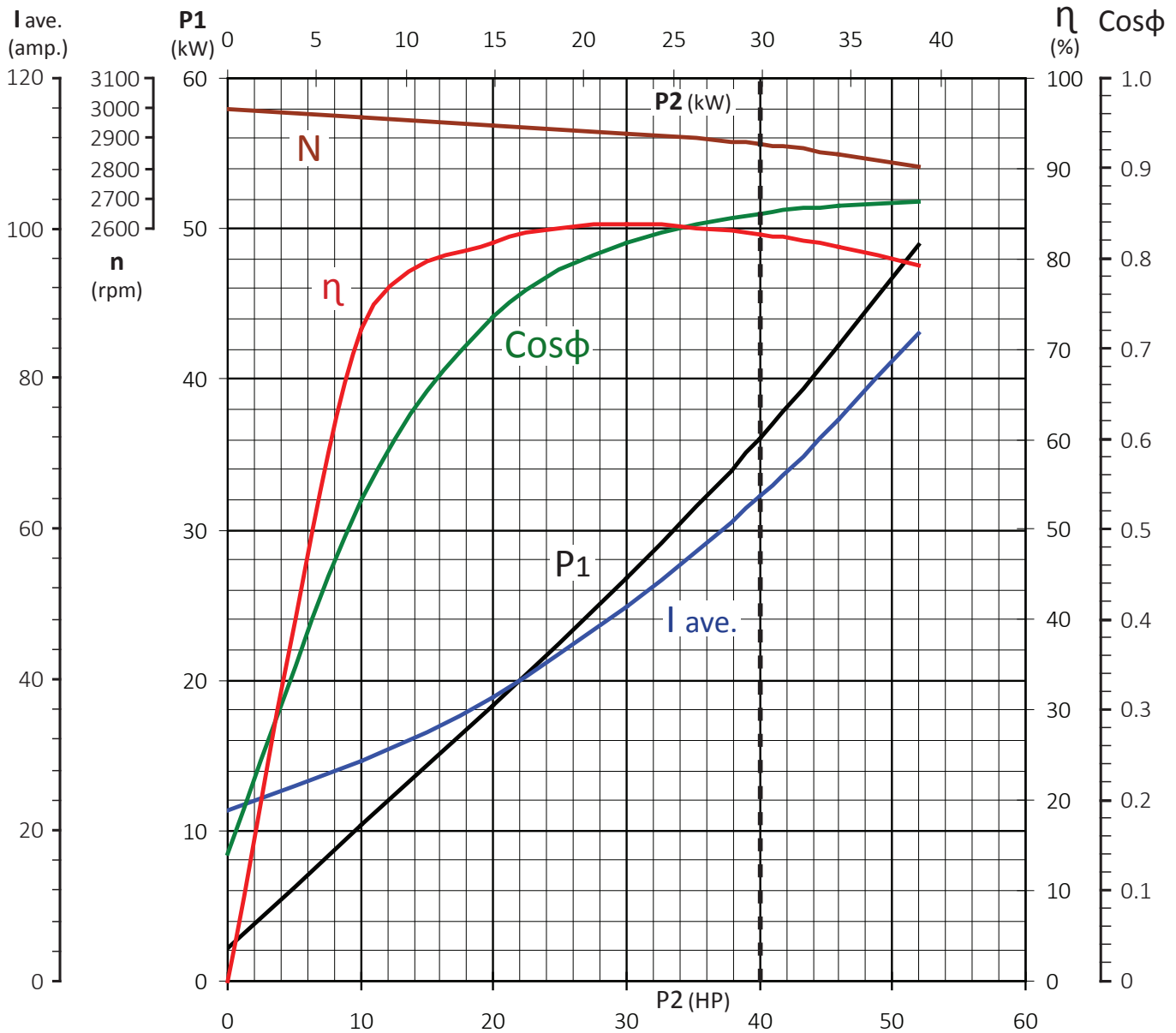

8" 50 HZ SERIES

Load	Frequency Hz	Volt ave. V	I ave. A	P1 kW	P1 HP	RPM	Torque Nm	P2 kW	P2 HP	Efficiency %	Cos pi
0%	50.00	380.0	22.68	2.12	2.84	2995.0	0.00	0.00	0.00	0.00%	0.142
25%	50.00	380.0	29.36	10.32	13.83	2972.2	23.97	7.46	10.00	72.29%	0.534
50%	50.00	380.0	37.73	18.25	24.46	2940.9	48.45	14.92	20.00	81.75%	0.735
75%	50.00	380.0	49.63	26.72	35.82	2914.3	73.33	22.38	30.00	83.76%	0.818
100%	50.00	380.0	64.52	36.05	48.32	2879.6	98.95	29.84	40.00	82.77%	0.849
115%	50.00	380.0	74.61	42.18	56.54	2846.6	115.12	34.32	46.00	81.36%	0.859
130%	50.00	380.0	86.13	48.92	65.58	2805.9	132.02	38.79	52.00	79.30%	0.863

Motor Performance Curve

tolerances according to NEMA standard and IEC 60034-1

50 HP | **37.3** kW | **380** Volt | **50** Hertz | **2** Pole

8" 50 HZ SERIES

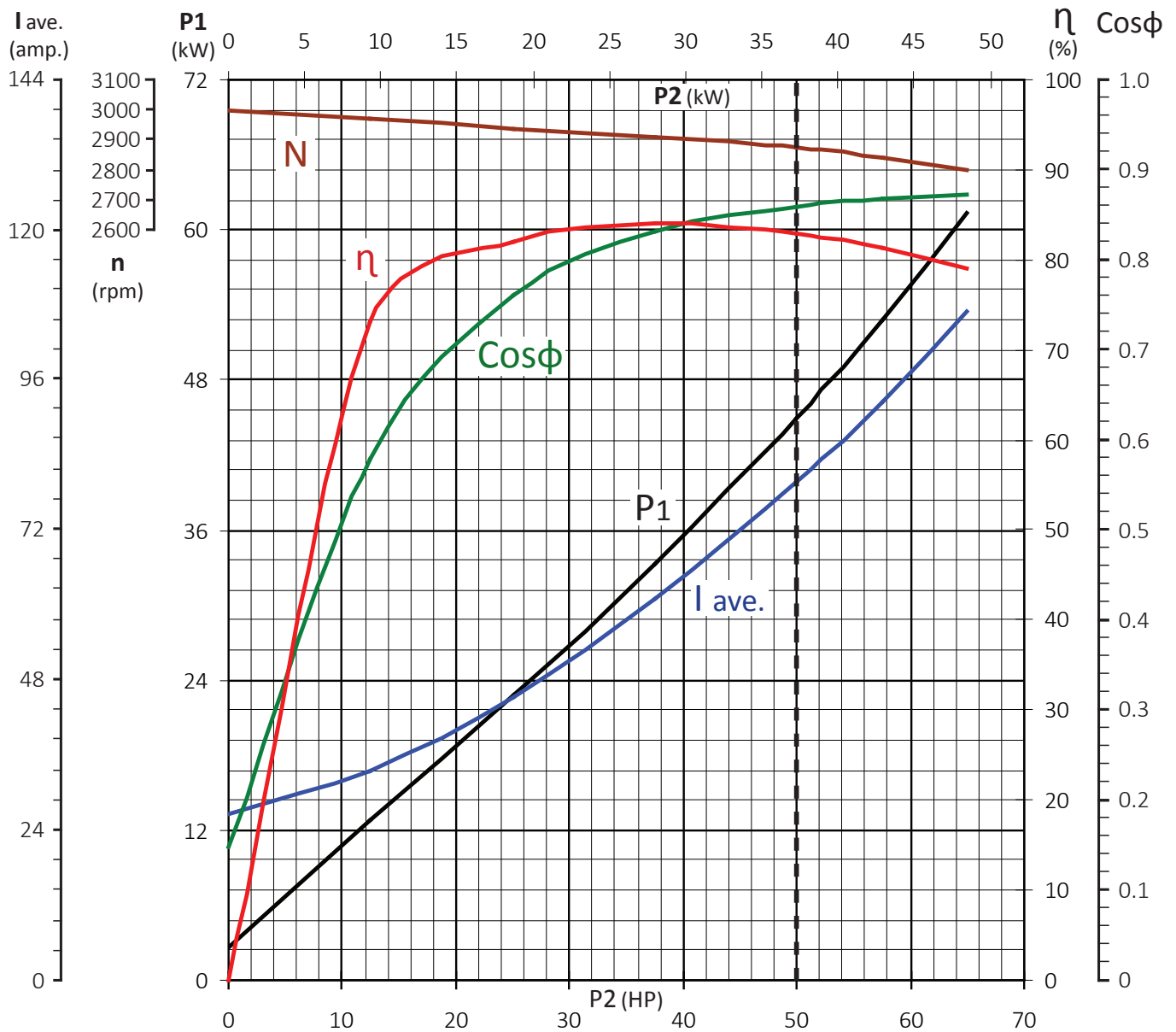

Load	Frequency Hz	Volt ave. V	I ave. A	P1 kW	P1 HP	RPM	Torque Nm	P2 kW	P2 HP	Efficiency %	Cos pi
0%	50.00	380.0	26.69	2.60	3.49	2994.9	0.00	0.00	0.00	0.00%	0.148
25%	50.00	380.0	33.48	12.76	17.10	2968.6	30.00	9.33	12.50	73.08%	0.579
50%	50.00	380.0	45.42	22.72	30.46	2939.2	60.59	18.65	25.00	82.09%	0.760
75%	50.00	380.0	60.85	33.32	44.66	2909.8	91.81	27.98	37.50	83.96%	0.832
100%	50.00	380.0	79.65	44.98	60.29	2874.8	123.90	37.30	50.00	82.93%	0.858
115%	50.00	380.0	92.39	52.78	70.75	2839.1	144.28	42.90	57.50	81.27%	0.868
130%	50.00	380.0	106.83	61.31	82.18	2801.6	165.28	48.49	65.00	79.09%	0.872

Motor Performance Curve

tolerances according to NEMA standard and IEC 60034-1

60 HP | **44.8** kW | **380** Volt | **50** Hertz | **2** Pole

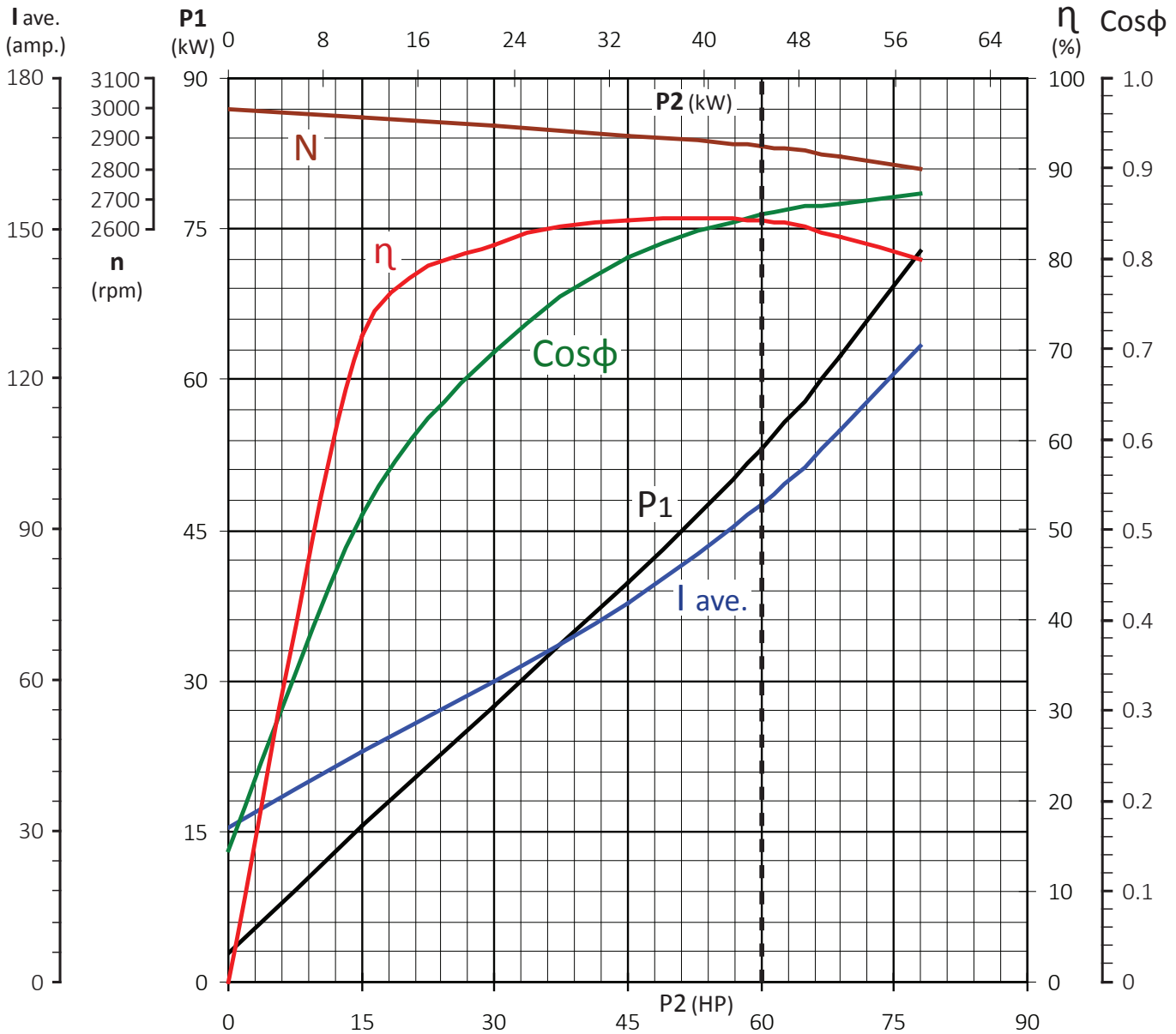

8" 50 HZ SERIES

Load	Frequency Hz	Volt ave. V	I ave. A	P1 kW	P1 HP	RPM	Torque Nm	P2 kW	P2 HP	Efficiency %	Cos pi
0%	50.00	380.0	30.91	2.97	3.98	2994.8	0.00	0.00	0.00	0.00%	0.146
25%	50.00	380.0	46.08	15.65	20.98	2969.2	35.99	11.19	15.00	71.50%	0.516
50%	50.00	380.0	59.88	27.43	36.77	2939.5	72.70	22.38	30.00	81.59%	0.696
75%	50.00	380.0	75.53	39.87	53.45	2909.7	110.17	33.57	45.00	84.20%	0.802
100%	50.00	380.0	95.06	53.12	71.21	2874.7	148.69	44.76	60.00	84.26%	0.849
115%	50.00	380.0	110.02	62.42	83.67	2839.4	173.12	51.47	69.00	82.46%	0.862
130%	50.00	380.0	126.81	72.78	97.56	2801.5	198.34	58.19	78.00	79.95%	0.872

Motor Performance Curve

tolerances according to NEMA standard and IEC 60034-1

75 HP | **56** kW | **380** Volt | **50** Hertz | **2** Pole

8" 50 HZ SERIES

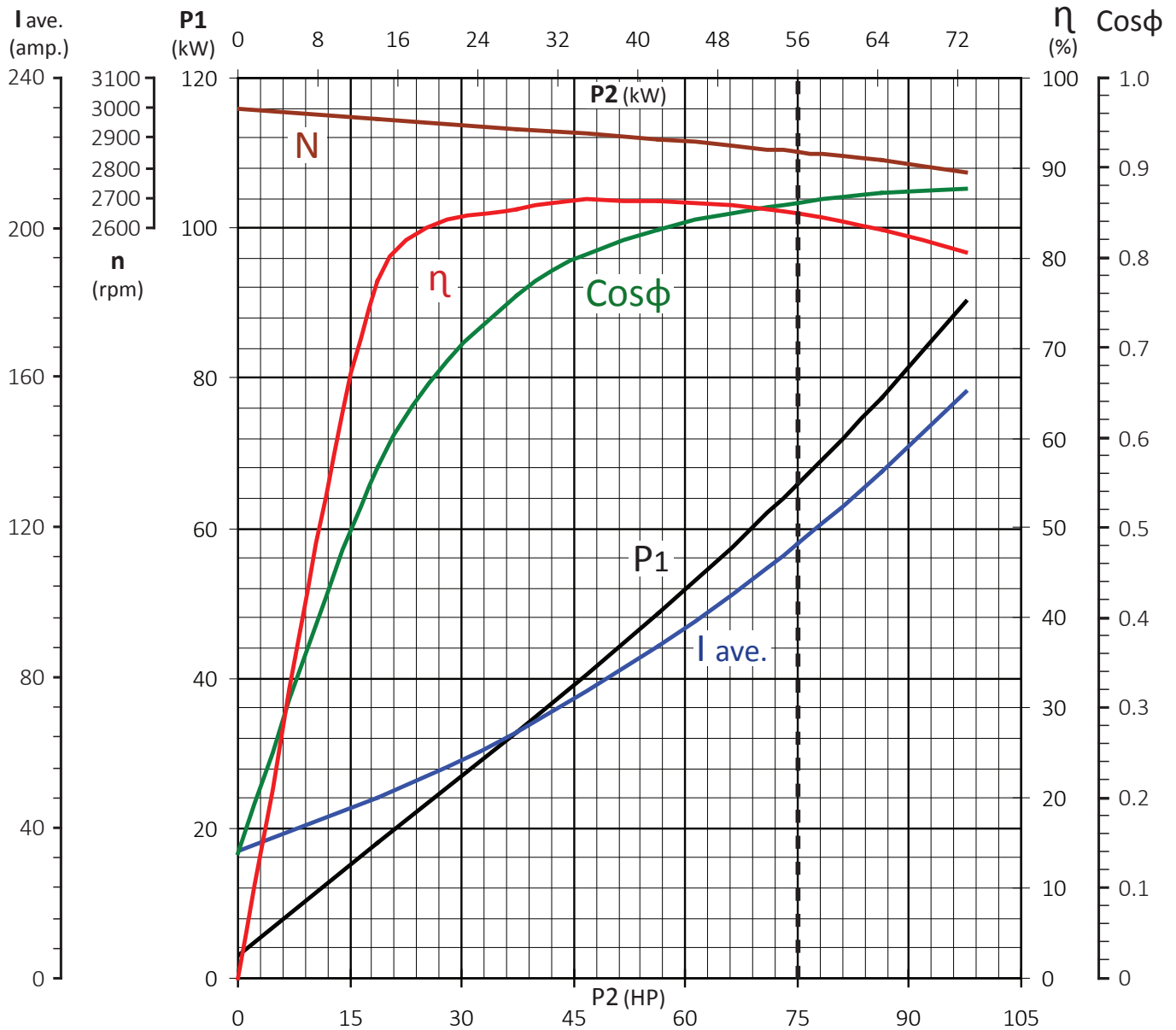

Load	Frequency Hz	Volt ave. V	I ave. A	P1 kW	P1 HP	RPM	Torque Nm	P2 kW	P2 HP	Efficiency %	Cos pi
0%	50.00	380.0	33.89	3.10	4.16	2996.5	0.00	0.00	0.00	0.00%	0.139
25%	50.00	380.0	48.37	18.05	24.20	2960.3	45.12	13.99	18.75	77.49%	0.567
50%	50.00	380.0	65.71	32.78	43.94	2930.3	91.16	27.98	37.50	85.34%	0.758
75%	50.00	380.0	88.77	48.55	65.08	2895.8	138.37	41.96	56.25	86.43%	0.831
100%	50.00	380.0	116.10	65.87	88.30	2855.3	187.12	55.95	75.00	84.94%	0.862
115%	50.00	380.0	134.85	77.48	103.86	2829.9	217.12	64.34	86.25	83.04%	0.873
130%	50.00	380.0	156.13	90.12	120.80	2787.2	249.20	72.74	97.50	80.71%	0.877

Motor Performance Curve

tolerances according to NEMA standard and IEC 60034-1

100 HP | **74.6** kW | **380** Volt | **50** Hertz | **2** Pole

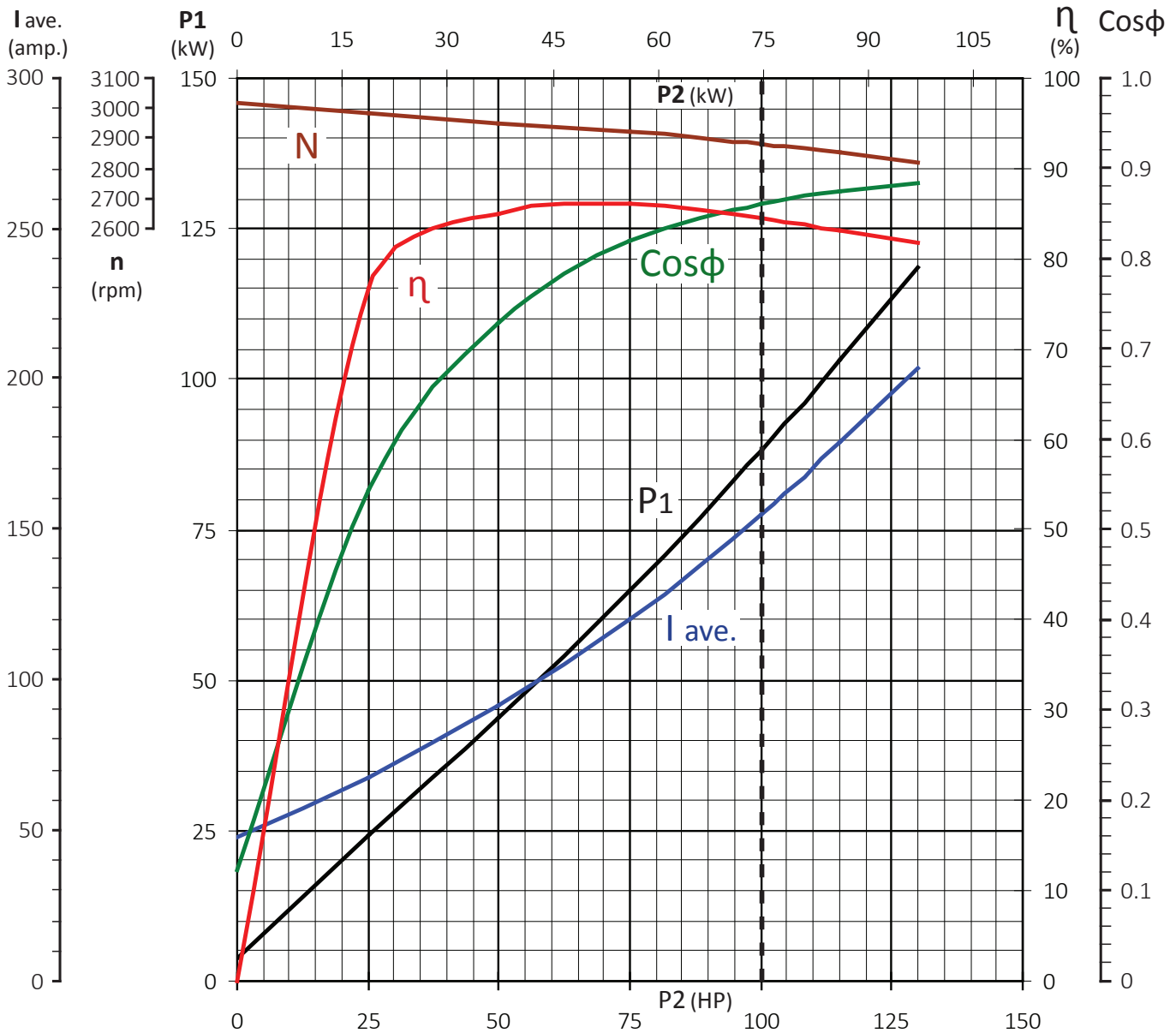

8" 50 HZ SERIES

Load	Frequency Hz	Volt ave. V	I ave. A	P1 kW	P1 HP	RPM	Torque Nm	P2 kW	P2 HP	Efficiency %	Cos pi
0%	50.00	380.0	47.93	3.88	5.20	2996.8	0.00	0.00	0.00	0.00%	0.123
25%	50.00	380.0	67.69	24.28	32.55	2961.0	60.15	18.65	25.00	76.81%	0.545
50%	50.00	380.0	91.52	43.85	58.78	2933.0	121.44	37.30	50.00	85.06%	0.728
75%	50.00	380.0	120.18	64.94	87.05	2900.6	184.20	55.95	75.00	86.16%	0.821
100%	50.00	380.0	155.43	88.18	118.20	2860.3	249.06	74.60	100.00	84.60%	0.862
115%	50.00	380.0	179.15	103.05	138.14	2833.0	289.17	85.79	115.00	83.25%	0.874
130%	50.00	380.0	203.80	118.44	158.77	2798.7	330.89	96.98	130.00	81.88%	0.883

Motor Performance Curve

tolerances according to NEMA standard and IEC 60034-1

125 HP | **93** kW | **380** Volt | **50** Hertz | **2** Pole

8" 50 HZ SERIES

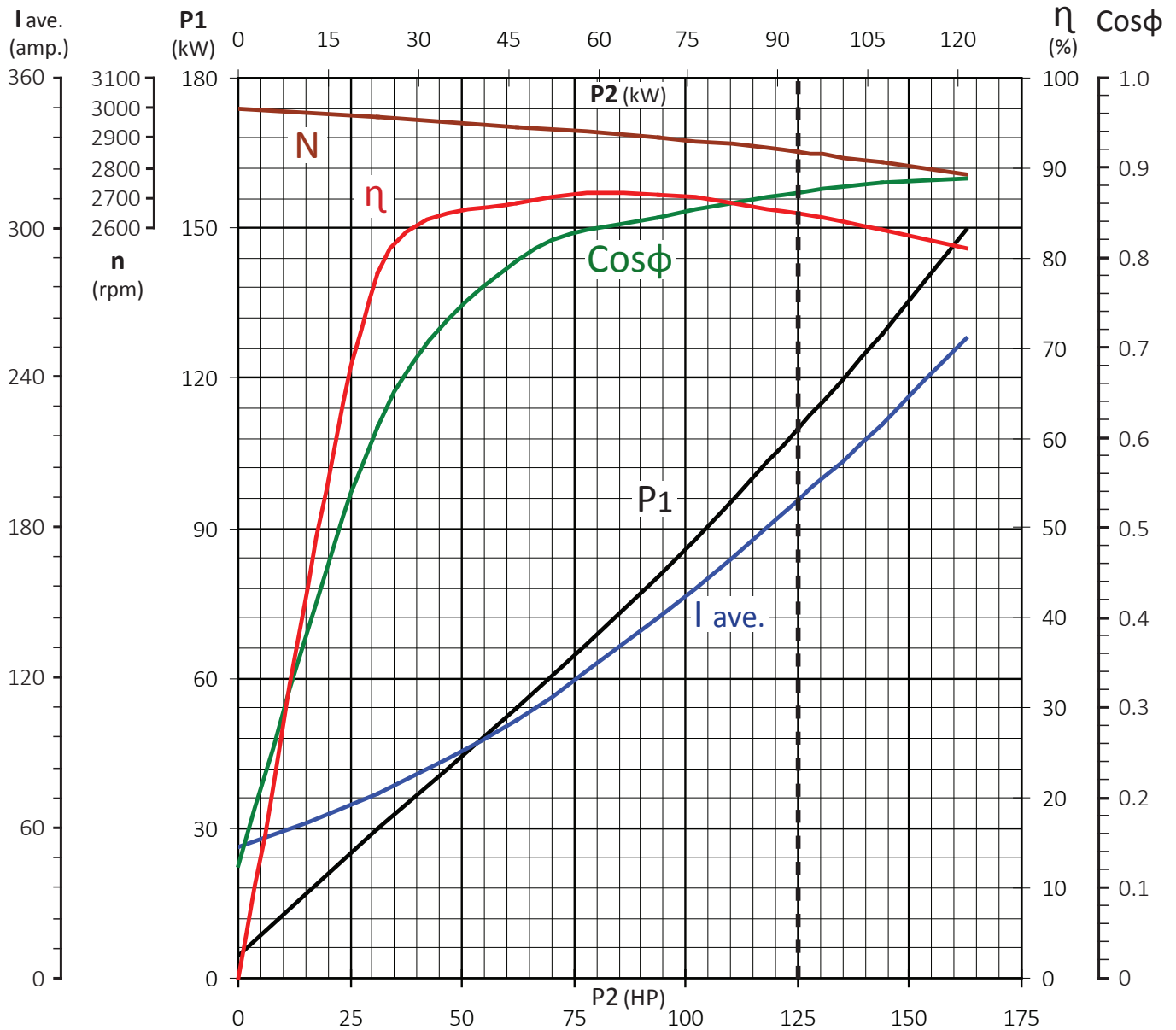

Load	Frequency Hz	Volt ave. V	I ave. A	P1 kW	P1 HP	RPM	Torque Nm	P2 kW	P2 HP	Efficiency %	Cos pi
0%	50.00	380.0	52.58	4.36	5.84	2998.5	0.00	0.00	0.00	0.00%	0.126
25%	50.00	380.0	73.81	29.78	39.92	2969.6	74.97	23.31	31.25	78.28%	0.613
50%	50.00	380.0	103.17	54.12	72.55	2937.1	151.59	46.63	62.50	86.15%	0.797
75%	50.00	380.0	144.49	80.45	107.84	2901.5	230.18	69.94	93.75	86.93%	0.846
100%	50.00	380.0	191.18	109.72	147.08	2855.1	311.89	93.25	125.00	84.99%	0.872
115%	50.00	380.0	221.71	128.85	172.72	2821.8	362.91	107.24	143.75	83.23%	0.883
130%	50.00	380.0	255.77	149.65	200.60	2778.6	416.62	121.23	162.50	81.01%	0.889

Motor Performance Curve

tolerances according to NEMA standard and IEC 60034-1

150 HP | **112** kW | **380** Volt | **50** Hertz | **2** Pole

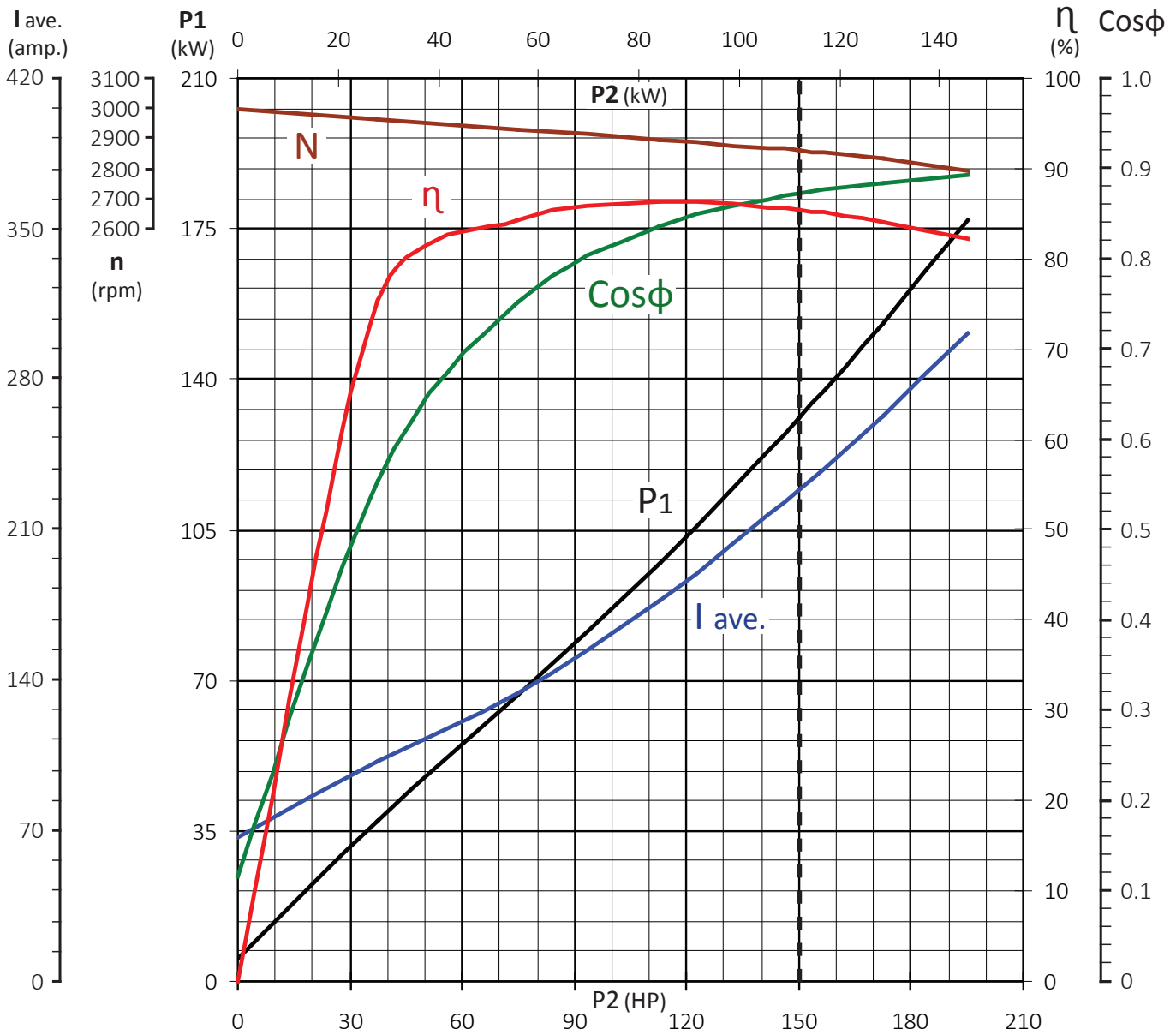

8" 50 HZ SERIES

Load	Frequency Hz	Volt ave. V	I ave. A	P1 kW	P1 HP	RPM	Torque Nm	P2 kW	P2 HP	Efficiency %	Cos pi
0%	50.00	380.0	66.88	5.15	6.90	2995.1	0.00	0.00	0.00	0.00%	0.117
25%	50.00	380.0	102.04	37.14	49.79	2963.2	90.15	27.98	37.50	75.32%	0.553
50%	50.00	380.0	134.30	66.38	88.98	2930.5	182.32	55.95	75.00	84.29%	0.751
75%	50.00	380.0	176.72	97.12	130.19	2896.9	276.65	83.93	112.50	86.41%	0.835
100%	50.00	380.0	228.34	131.05	175.67	2859.8	373.66	111.90	150.00	85.39%	0.872
115%	50.00	380.0	263.49	153.30	205.50	2830.3	434.17	128.69	172.50	83.94%	0.884
130%	50.00	380.0	301.73	177.14	237.45	2793.2	497.33	145.47	195.00	82.12%	0.892

Motor Performance Curve

tolerances according to NEMA standard and IEC 60034-1

175 HP | **131** kW | **380** Volt | **50** Hertz | **2** Pole

8" 50 HZ SERIES

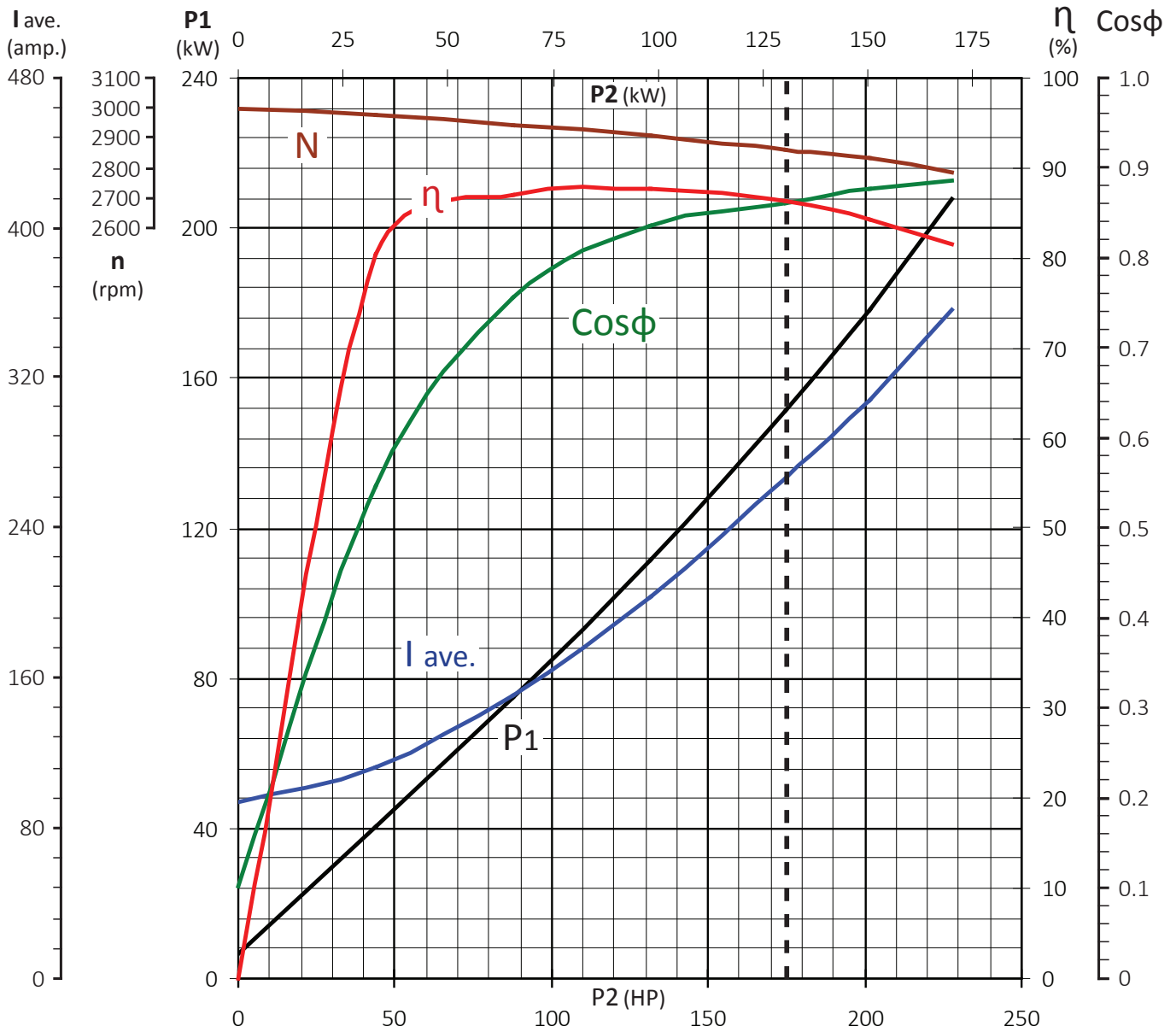

Load	Frequency Hz	Volt ave. V	I ave. A	P1 kW	P1 HP	RPM	Torque Nm	P2 kW	P2 HP	Efficiency %	Cos pi
0%	50.00	380.0	94.11	6.38	8.55	2997.3	0.00	0.00	0.00	0.00%	0.103
25%	50.00	380.0	112.87	40.56	54.37	2974.3	104.79	32.64	43.75	80.47%	0.546
50%	50.00	380.0	150.63	75.05	100.60	2941.4	211.92	65.28	87.50	86.98%	0.757
75%	50.00	380.0	202.96	111.54	149.52	2905.7	321.78	97.91	131.25	87.78%	0.835
100%	50.00	380.0	266.60	151.25	202.75	2860.3	435.85	130.55	175.00	86.31%	0.862
115%	50.00	380.0	308.78	178.23	238.91	2830.6	506.48	150.13	201.25	84.24%	0.877
130%	50.00	380.0	356.84	207.85	278.62	2784.8	581.97	169.72	227.50	81.65%	0.885

Motor Performance Curve

tolerances according to NEMA standard and IEC 60034-1

200 HP | **150** kW | **380** Volt | **50** Hertz | **2** Pole

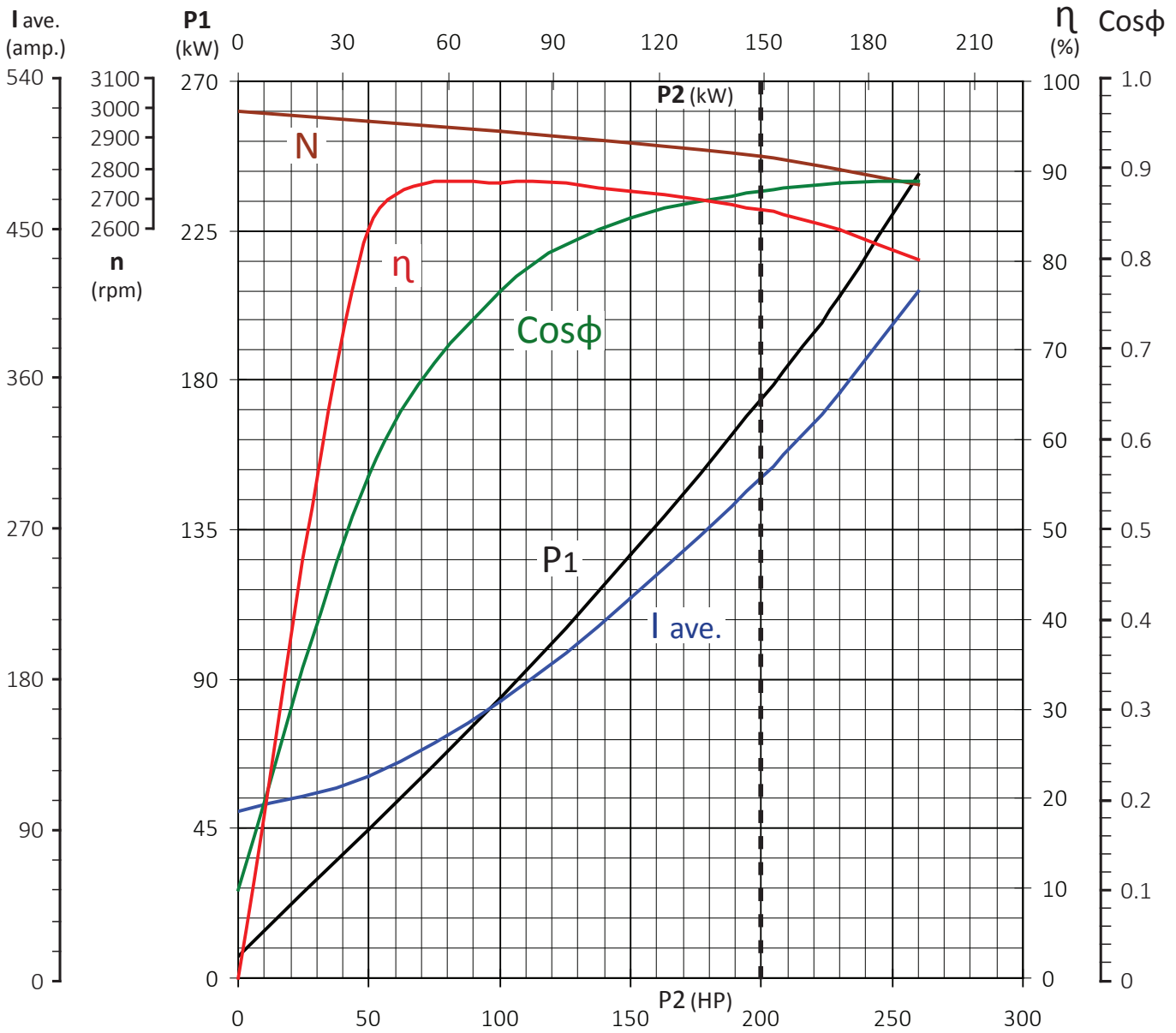

8" 50 HZ SERIES

Load	Frequency Hz	Volt ave. V	I ave. A	P1 kW	P1 HP	RPM	Torque Nm	P2 kW	P2 HP	Efficiency %	Cos pi
0%	50.00	380.0	100.53	6.55	8.78	2998.0	0.00	0.00	0.00	0.00%	0.099
25%	50.00	380.0	121.39	44.66	59.87	2965.3	120.12	37.30	50.00	83.52%	0.559
50%	50.00	380.0	166.85	84.12	112.76	2932.2	242.95	74.60	100.00	88.68%	0.766
75%	50.00	380.0	228.73	127.51	170.92	2894.7	369.15	111.90	150.00	87.76%	0.847
100%	50.00	380.0	301.35	174.14	233.43	2849.6	499.98	149.20	200.00	85.68%	0.878
115%	50.00	380.0	352.29	205.43	275.38	2804.5	584.22	171.58	230.00	83.52%	0.886
130%	50.00	380.0	413.81	242.12	324.56	2752.0	673.04	193.96	260.00	80.11%	0.889

Technical DETAILS

8" SERIES

Motor Dimensions and Weights

Motor Type	Motor Size		L Motor Length (inch)	L1 Motor Length (inch)	Packing Dimension W x H x L (inch)	Weight (Lbs)	
	HP	kW				Without Packing	With Packing
8SME 0400-2	40	30	49.4	45.4	11.8 x 15.8 x 55.4	375	405
8SME 0500-2	50	37	52.6	48.6	11.8 x 15.8 x 56.3	410	440
8SME 0600-2	60	45	55.3	51.3	11.8 x 15.8 x 60.4	440	486
8SME 0750-2	75	56	59.3	55.3	11.8 x 15.8 x 63.7	476	519
8SME 1000-2	100	75	64.4	60.4	11.8 x 15.8 x 68.7	530	578
8SME 1250-2	125	93	72.6	68.6	11.8 x 15.8 x 76.5	620	675
8SME 1500-2	150	112	76.5	72.5	11.8 x 15.8 x 80.3	662	719
8SME 1750-2	175	130	76.5	72.5	11.8 x 15.8 x 80.3	666	723
8SME 200-2	200	150	80.3	76.3	11.8 x 15.8 x 86.3	714	771

8SME 0400-2	40	30	49.4	45.4	11.8 x 15.8 x 55.4	383	413
8SME 0500-2	50	37	52.6	48.6	11.8 x 15.8 x 56.3	418	448
8SME 0600-2	60	45	55.3	51.3	11.8 x 15.8 x 60.4	448	494
8SME 0750-2	75	56	59.3	55.3	11.8 x 15.8 x 63.7	488	528
8SME 1000-2	100	75	64.4	60.4	11.8 x 15.8 x 68.7	542	588
8SME 1250-2	125	93	72.6	68.6	11.8 x 15.8 x 76.5	636	686
8SME 1500-2	150	112	76.5	72.5	11.8 x 15.8 x 80.3	678	731
8SME 1750-2	175	130	76.5	72.5	11.8 x 15.8 x 80.3	681	736
8SME 200-2	200	150	80.5	76.5	11.8 x 15.8 x 86.3	729	786

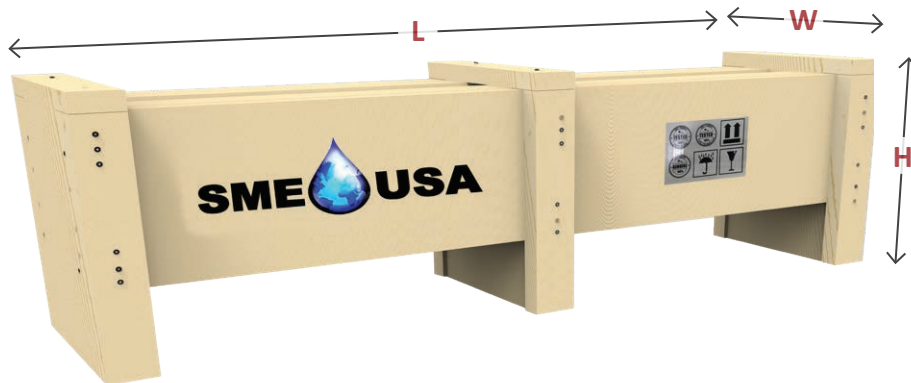
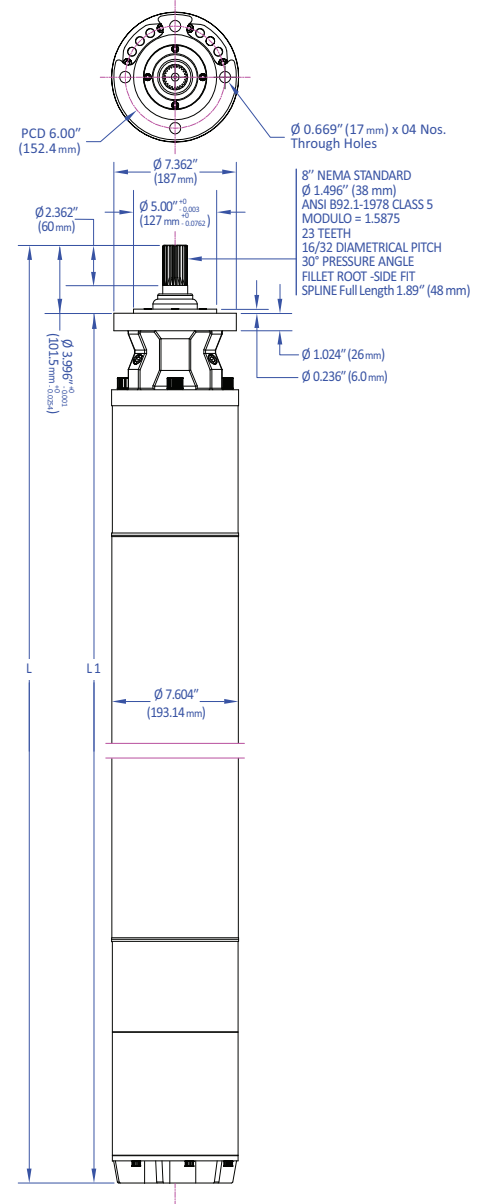

Parts LIST with Material & Quantity

Pos.	Item Code	Part Name	Material	Qty	Unit
1	60161050	Sand Guard	Rubber	1	Nr
2	60161252	Bolt Allen M6 x 20	Stainless Steel	14	Nr
3	60161085	Mechanical Seal Cover	Stainless Steel	1	Nr
4	60161127	Oil Seal 38x60x10	NBR	2	Nr
5	60161125	Bush Seal Support	Cast Iron	1	Nr
6	60161220	O-Ring 65x2,5	NBR	1	Nr
7	60161275	Mechanical Seal Complete	Silicon Tungsten Carbide (WC) + NBR + Stainless Steel	1	Nr
8	60161065	Top Piece / Upper Support Double Flange	Cast Iron	1	Nr
9	60101485	PT 100 Sensor	Stainless Steel	1	Nr
10	60161250	Bolt Allen M8x20	Stainless Steel	14	Nr
11	60161267	Washer Bonded / Dowty Seal M8	NBR/ Stainless Steel AISI 316	1	Nr
12	60101157	Washer Bonded / Dowty Seal M10	NBR / Stainless Steel AISI 316	8	Nr
13	60101068	Bolt Allen M10 x 16	Stainless Steel	2	Nr
14	60161255	Bolt Allen M16 x 65	Stainless Steel	4	Nr
15	60161272	Washer Bonded / Dowty Seal M16	NBR / Stainless Steel AISI 316	4	Nr
16	60161253	Bolt Allen M8 x 25	Stainless Steel	2	Nr
17	60161150	Cable Top Cover Plate	Carbon Steel	2	Nr
18	60161092	Washer nylon	Nylon	2	Nr
19	60161095	Gasket Rubber	NBR	1	Nr
20	60161254	Bolt Allen M8 x 35	Stainless Steel	1	Nr
21	60161263	Spring Washer M8	Stainless Steel	1	Nr
22	60161262	Nut Hex M8	Stainless Steel	1	Nr
23	60161080	Upper Bearing Housing	Cast Iron	1	Nr
24	60161105	Upper Thrust Bearing	Brass	1	Nr
25	60101142	Screw CSK M4x10	Stainless Steel	6	Nr
26	60161020	Carbon Bush	Carbon	4	Nr
27	60161042	Gasket Top Piece	Tesnit	1	Nr
28	60161315	Upper Threaded Socket	Cast Iron	1	Nr
29	60161215	O-Ring 165x2,5	NBR	2	Nr
30A	601611XX	Motor Lead Cable (1 x 10/16/25/35/50mm ²)	Copper + Rubber	48	Ft
30B	60101197	Cable for Earth 1 x 12 mm ²	Copper + PVC	16	Ft
31	60161594	Flange (200-140-46)	Stainless Steel	2	Nr
32	601616XX	Stator Stack (Assembly)	Silicon Steel (50C800) + SS304	1	Set
33	601063XX	Rotor Shaft	Stainless Steel (SS431)	1	Nr
34	60161660	Rotor Lamination (Including Shaft + Copper Bars+ End Ring)	Silicon Steel (50C800) + Stainless Steel + Copper	1	Set
35	60101145	Key for End Shaft	Stainless Steel	1	Nr
36	60161320	Lower Bearing Housing	Cast Iron	1	Nr
37	60161280K	Thrust Bearing	Stainless Steel / Carbon	1	Set
38	60161040	Gasket Thrust Support	Tesnit	1	Nr
39	60161070	Thrust Support	Cast Iron	1	Nr
40	60161260	Bolt Allen M10x190	Stainless Steel AISI 304	6	Nr
41	60161000	Adjustment Bolt	Stainless Steel	1	Nr
42	60161010	Lock Washer Adj. Bolt	MS	1	Nr
43	60101045	Diaphragm Rubber	NBR	1	Nr
44	60161130	Diaphragm Support	Cast Iron	1	Nr
45	60161037	Bottom Plate	Cast Iron	1	Nr

Available Horse Power

From: 75 HP (56 kW)
To: 270 HP (200 kW)

Available Voltages

460 Volts - 60 Hertz
380 Volts - 50 Hertz

Available Speed

2-Pole

Available Insulation Class

Standard: Y

Available Materials Of Construction

Standard: Cast Iron Ends with NSF
Certified Epoxy
Optional: Complete 316L SS



**DOUBLE FLANGE
10-INCH BOREHOLE
SUBMERSIBLE ELECTRIC
REWINDABLE MOTOR**

10SME

✓ Key Features

10SME 10" submersible motors have been designed and produced according to the market's requirements. During the design and material selection phase, all efforts were made to offer an energy efficient product which stands for reliability, excellent quality, and long trouble free life.

The newly enhanced 10SME series of 10" submersible motors is specifically engineered for compatibility with VFD (Variable Frequency Drive) outputs, making it an ideal choice for solar-powered and other high-efficiency applications.

These 10" water-filled submersible motors have asynchronous three phase rewindable stator and a robust squirrel cage rotor.

- Wet Stator Design
- High Grade Material
- Easy Maintenance
- Long Service Life
- High Thermal Capacity
- High Efficiency
- Re-windable
- Eco Friendly
- NSF and ISO Certified
- Industrial, Commercial, Agriculture and Oil & Gas Application

⚙️ Technical Specification

Degree of protection	IP68
Insulation class	Y*
Working temperature	122 °F
Voltage tolerance	+ 6% / - 10%
Mounting position	Vertical/Horizontal
Min./Max. flow rate speed	0.5-12 ft/sec
Max. immersion depth	650 feet
Max. starts per hour	10
Packing	wooden crate

* Higher insulation wire class available.

☰ Specificaions

Winding:

Electrolytic Solid Copper wire wrapped in BOPET + BOPP Insulation rated for temperatures over 100°C (212 °F) that allows more copper in the current slots. This technology allows the motor to run much cooler and achieve higher than normal horsepower ratings in standard frame sizes.

Stator:

All motors include an increased Stator stack length and combined M800 low-loss electrical magnetic sheet for a cooler running motor.

Rotor:

Increased stack length with M800 low-loss electrical magnetic sheet assembled and designed with newest technology and high grade copper bars.

Spline Shaft:

AISI 400 series stainless steel induction hardened & ground to operate in severe conditions. Dimensions according to international 8"/10" NEMA keyed type and as per international standards.

Shaft Bearings:

Dual Water lubricated guide bearings made of high grade carbon, are fixed in upper and lower brackets for optimal operation in sandy wells and pump vibration control.

Thrust Bearings:

All SME submersible motors have Kingsbury type thrust bearing. The thrust assembly consists of a high quality carbon disc with hardened stainless steel shoes to handle necessary pump thrust loads. Available with axial load capacity of 27000 Lbs.

Seal Configuration:

SME offers a triple seal configuration that consists of two outer back to back lip seals in NBR with an inner Silicon Tungsten Carbide Seal for optimum protection in sandy wells.

Pressure Equalizing System:

Pressure compensation is managed by using a suitably sized NBR bellow to allow for expansion of the internal water as it heats up - or - from external pressure due to the depth of submergence.

Bearing Housings:

High resistance cast iron upper & lower bearing housing with NSF certified epoxy coating.

Filler Fluid:

Water mixed with NSF compliant Mono Propylene Glycol / Glycerin for optimal cooling, lubrication and corrosion resistance.

Note: All specifications are subject to change without any prior notice.

Electrical DATA

Electrical Data @ Three Phase - 2 Poles - 60 Hz / 460 Volt - 50 Hz / 380 Volt

Motor Type	Motor Size		Thrust Load (lbs)	RPM	Full Load Current (Amps)	S.F Load Current (Amps)	Starting Current (Amps)	KVA Code	Cos. Φ at Full Load	Efficiency at Full Load (%)	Service Factor	
	HP	kW										
60 Hz - 460 Volt	10SME 075-2	75	56	27000	3490	96.7	109.4	525	F	0.84	86.0	1.15
	10SME 100-2	100	75	27000	3485	128.7	146.3	717	G	0.85	85.7	1.15
	10SME 125-2	125	93	27000	3495	161.0	183.0	915	G	0.84	86.1	1.15
	10SME 150-2	150	112	27000	3505	192.2	218.9	1116	G	0.84	86.9	1.15
	10SME 175-2	175	130	27000	3510	226.4	257.3	1338	G	0.83	87.3	1.15
	10SME 200-2	200	150	27000	3505	257.6	292.7	1552	G	0.83	87.2	1.15
	10SME 250-2	250	186	27000	3495	321.4	370.7	2002	H	0.84	86.7	1.15
	10SME 270-2	270	200	27000	3495	344.3	395.8	2177	H	0.85	86.8	1.15
50 Hz - 380 Volt	10SME 075-2	75	56	27000	2875	115.7	-	556	E	0.86	85.6	1
	10SME 100-2	100	75	27000	2870	153.1	-	750	E	0.86	85.8	1
	10SME 125-2	125	93	27000	2880	192.2	-	961	F	0.86	85.8	1
	10SME 150-2	150	112	27000	2885	229.0	-	1168	F	0.86	86.6	1
	10SME 175-2	175	130	27000	2890	270.1	-	1404	F	0.84	87.1	1
	10SME 200-2	200	150	27000	2885	307.3	-	1629	F	0.85	86.9	1
	10SME 250-2	250	186	27000	2885	384.4	-	2076	F	0.85	86.3	1

10" SERIES

Technical DETAILS

Size & Dimensions Motor Leads @ 2 Pole, Three Phase
60 Hz - 460 Volt, 50 Hz - 380 Volt

Sr: No.	Motor Size		Lead Size			Dimension Dia (inch)	Cable Length (Feet)	Qty (Nr.)	
	HP	kW	Core	mm ²	AWG				
DOL	1	75 ~ 100	56 ~ 75	1	25	4	0.53	16	3
	2	125	93	1	35	2	0.59	16	3
	3	150 ~ 175	112 ~ 130	1	50	1	0.68	16	3
	4	200	150	1	70	2/0	0.77	16	3
	5	250 ~ 270	186 ~ 200	1	95	3/0	0.87	16	3
SD	6	75 ~ 175	56 ~ 130	1	25	4	0.53	16	6
	7	200 ~ 250	150 ~ 186	1	35	2	0.59	16	6
	8	270	200	1	50	1	0.68	16	6

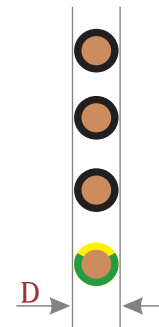

Additional core 1 x 12 mm² 16 feet for earthing.

Motor Performance Curve

tolerances according to NEMA standard and IEC 60034-1

75 HP | **56** kW | **460** Volt | **60** Hertz | **2** Pole

10" 60 HZ SERIES

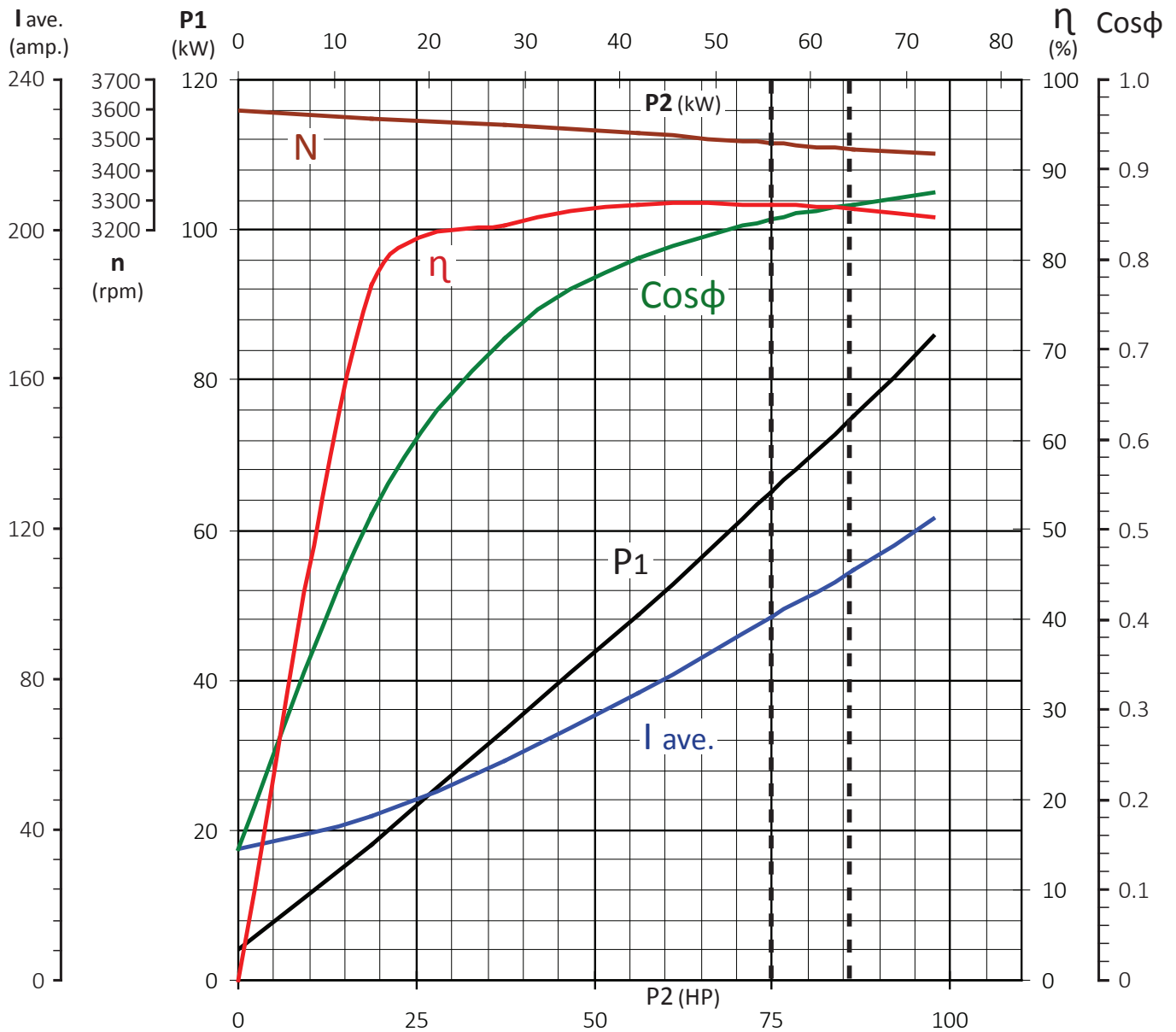

Load	Frequency Hz	Volt ave. V	I ave. A	P1 kW	P1 HP	RPM	Torque Nm	P2 kW	P2 HP	Efficiency %	Cos pi
0%	60.00	460.0	34.80	4.02	5.39	3596.6	0.00	0.00	0.00	0.00%	0.145
25%	60.00	460.0	43.91	18.12	24.29	3572.7	37.39	13.99	18.75	77.19%	0.518
50%	60.00	460.0	58.64	33.36	44.72	3547.9	75.29	27.98	37.50	83.86%	0.714
75%	60.00	460.0	76.34	48.78	65.39	3521.0	113.81	41.96	56.25	86.02%	0.802
100%	60.00	460.0	96.74	65.05	87.20	3490.2	153.08	55.95	75.00	86.01%	0.844
115%	60.00	460.0	109.41	75.14	100.72	3471.0	177.02	64.34	86.25	85.63%	0.862
130%	60.00	460.0	123.10	85.72	114.91	3451.8	201.22	72.74	97.50	84.85%	0.874

Motor Performance Curve

tolerances according to NEMA standard and IEC 60034-1

100 HP | **74.6** kW | **460** Volt | **60** Hertz | **2** Pole

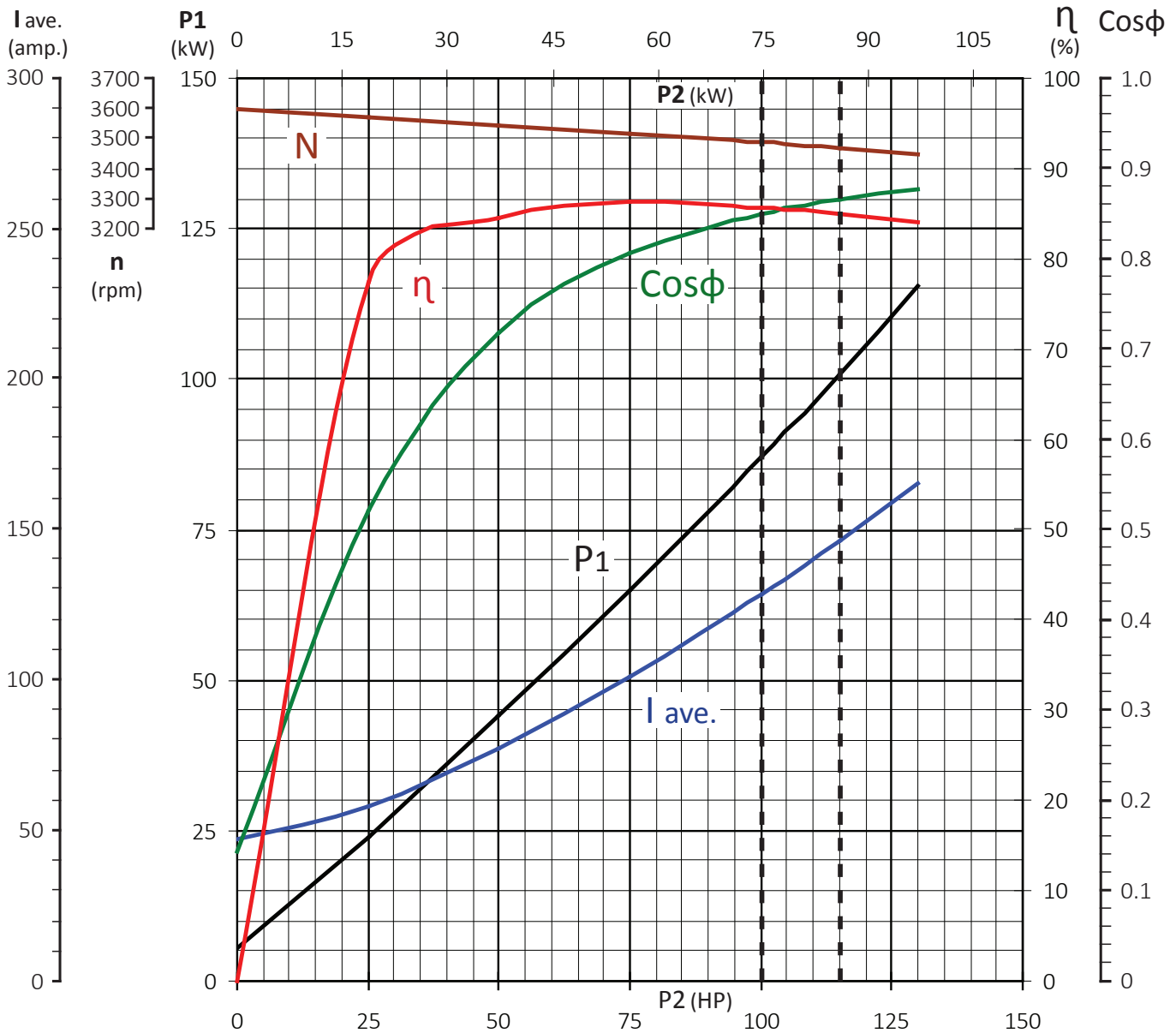

10" 60 HZ SERIES

Load	Frequency Hz	Volt ave. V	I ave. A	P1 kW	P1 HP	RPM	Torque Nm	P2 kW	P2 HP	Efficiency %	Cos pi
0%	60.00	460.0	47.13	5.37	7.20	3596.1	0.00	0.00	0.00	0.00%	0.143
25%	60.00	460.0	57.94	24.05	32.24	3572.0	49.86	18.65	25.00	77.55%	0.521
50%	60.00	460.0	77.13	44.12	59.14	3545.9	100.45	37.30	50.00	84.54%	0.718
75%	60.00	460.0	100.88	64.78	86.84	3517.6	151.89	55.95	75.00	86.37%	0.806
100%	60.00	460.0	128.66	87.03	116.66	3485.2	204.40	74.60	100.00	85.72%	0.849
115%	60.00	460.0	146.31	100.95	135.32	3465.5	236.40	85.79	115.00	84.98%	0.866
130%	60.00	460.0	165.14	115.52	154.85	3445.6	268.77	96.98	130.00	83.95%	0.878

Motor Performance Curve

tolerances according to NEMA standard and IEC 60034-1

125 HP | **93** kW | **460** Volt | **60** Hertz | **2** Pole

10" 60 HZ SERIES

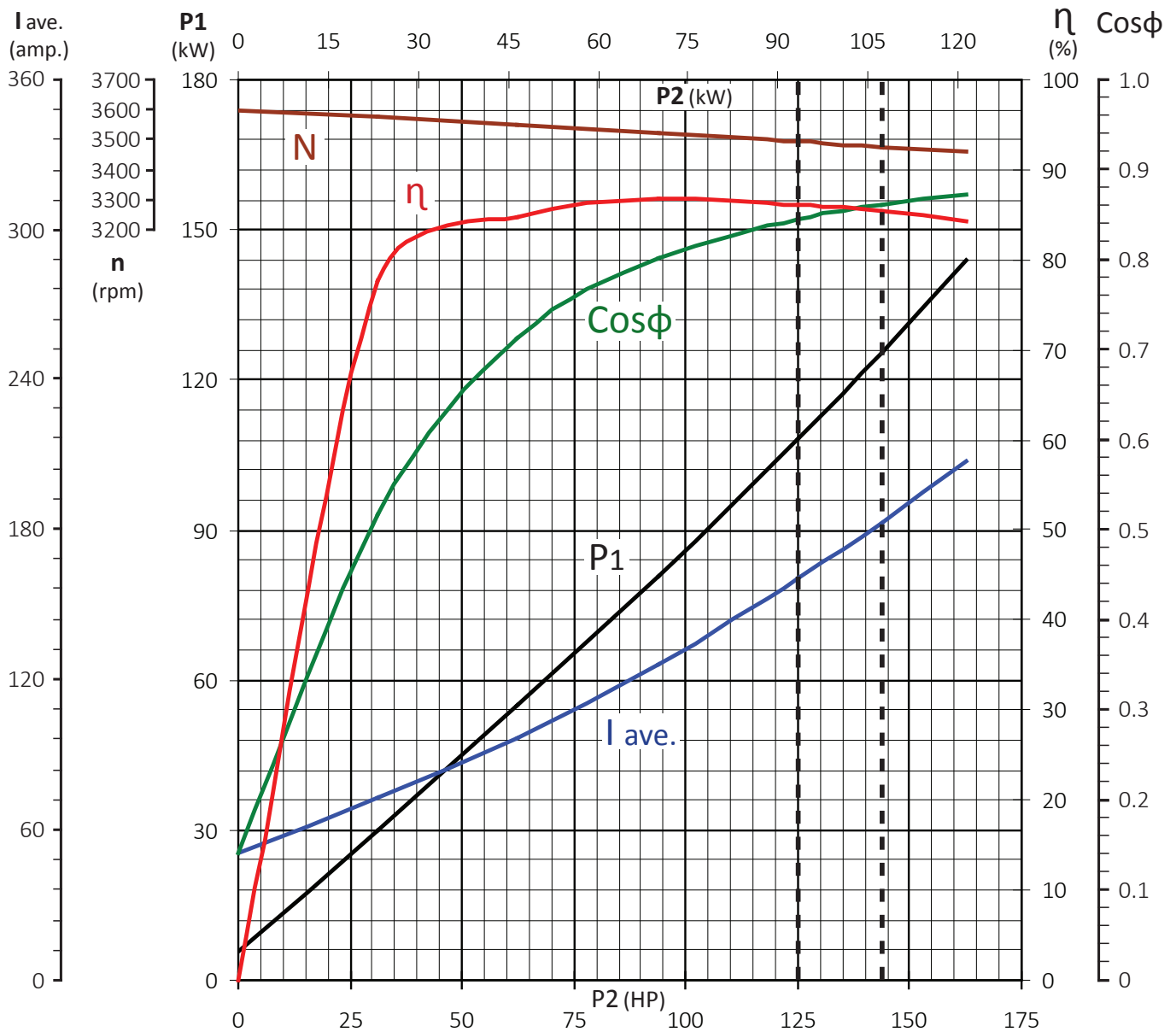

Load	Frequency Hz	Volt ave. V	I ave. A	P1 kW	P1 HP	RPM	Torque Nm	P2 kW	P2 HP	Efficiency %	Cos pi
0%	60.00	460.0	51.09	5.78	7.75	3597.3	0.00	0.00	0.00	0.00%	0.142
25%	60.00	460.0	72.81	30.05	40.28	3574.2	62.28	23.31	31.25	77.58%	0.518
50%	60.00	460.0	96.72	55.02	73.75	3550.4	125.41	46.63	62.50	84.74%	0.714
75%	60.00	460.0	126.22	80.65	108.11	3524.5	189.49	69.94	93.75	86.72%	0.802
100%	60.00	460.0	161.03	108.28	145.15	3494.9	254.79	93.25	125.00	86.12%	0.844
115%	60.00	460.0	182.99	125.53	168.26	3476.8	294.53	107.24	143.75	85.43%	0.861
130%	60.00	460.0	207.13	143.90	192.90	3458.7	334.70	121.23	162.50	84.24%	0.872

Motor Performance Curve

tolerances according to NEMA standard and IEC 60034-1

150 HP | **112** kW | **460** Volt | **60** Hertz | **2** Pole

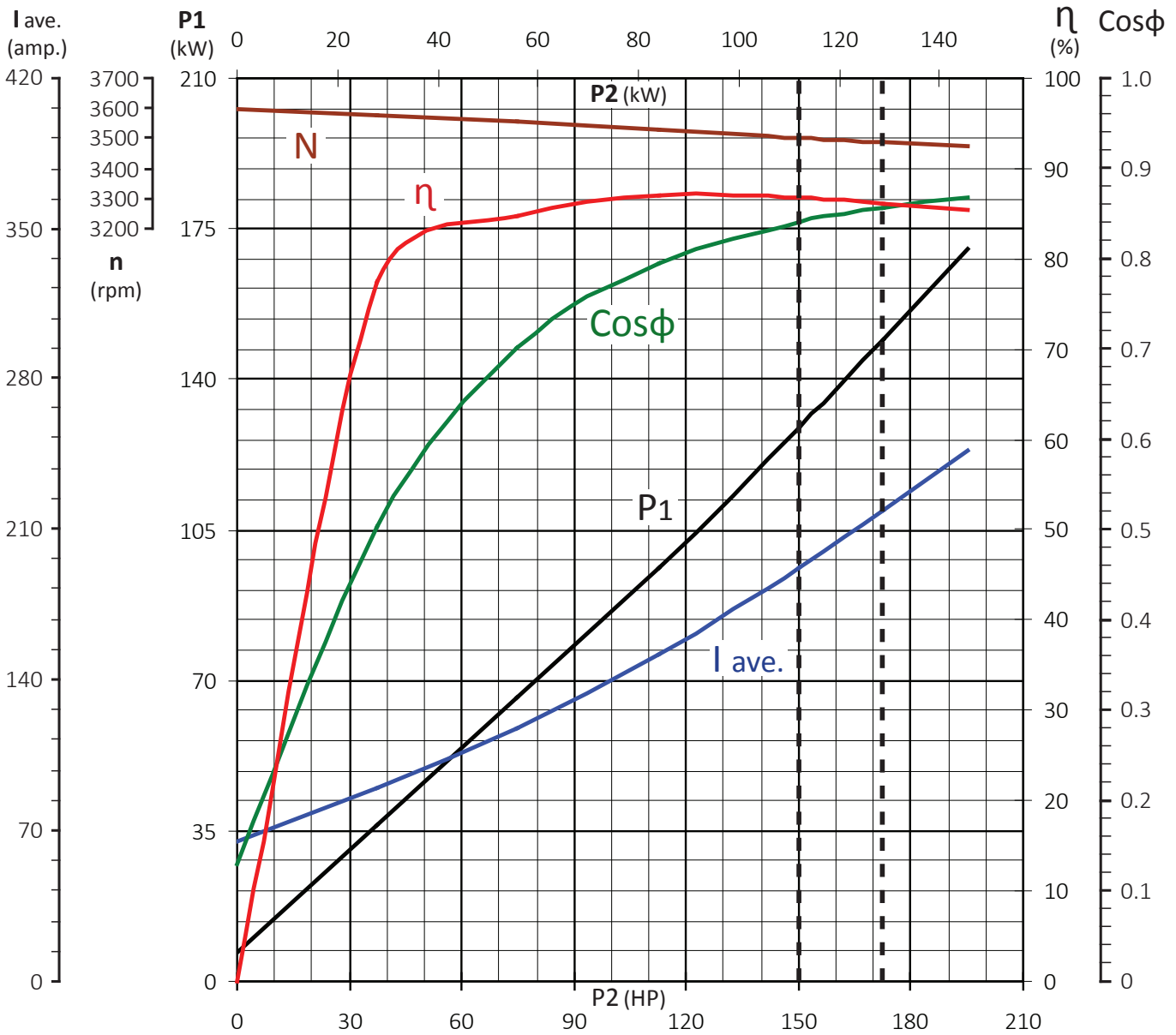

10" 60 HZ SERIES

Load	Frequency Hz	Volt ave. V	I ave. A	P1 kW	P1 HP	RPM	Torque Nm	P2 kW	P2 HP	Efficiency %	Cos pi
0%	60.00	460.0	64.88	6.72	9.01	3597.0	0.00	0.00	0.00	0.00%	0.130
25%	60.00	460.0	90.13	36.12	48.42	3577.5	74.67	27.98	37.50	77.45%	0.503
50%	60.00	460.0	118.09	66.05	88.54	3555.0	150.29	55.95	75.00	84.71%	0.702
75%	60.00	460.0	152.09	96.33	129.13	3531.6	226.93	83.93	112.50	87.12%	0.795
100%	60.00	460.0	192.18	128.77	172.61	3504.8	304.89	111.90	150.00	86.90%	0.841
115%	60.00	460.0	218.85	149.43	200.31	3488.0	352.31	128.69	172.50	86.12%	0.857
130%	60.00	460.0	246.52	170.48	228.53	3471.5	400.16	145.47	195.00	85.33%	0.868

Motor Performance Curve

tolerances according to NEMA standard and IEC 60034-1

175 HP | **131** kW | **460** Volt | **60** Hertz | **2** Pole

10" 60 HZ SERIES

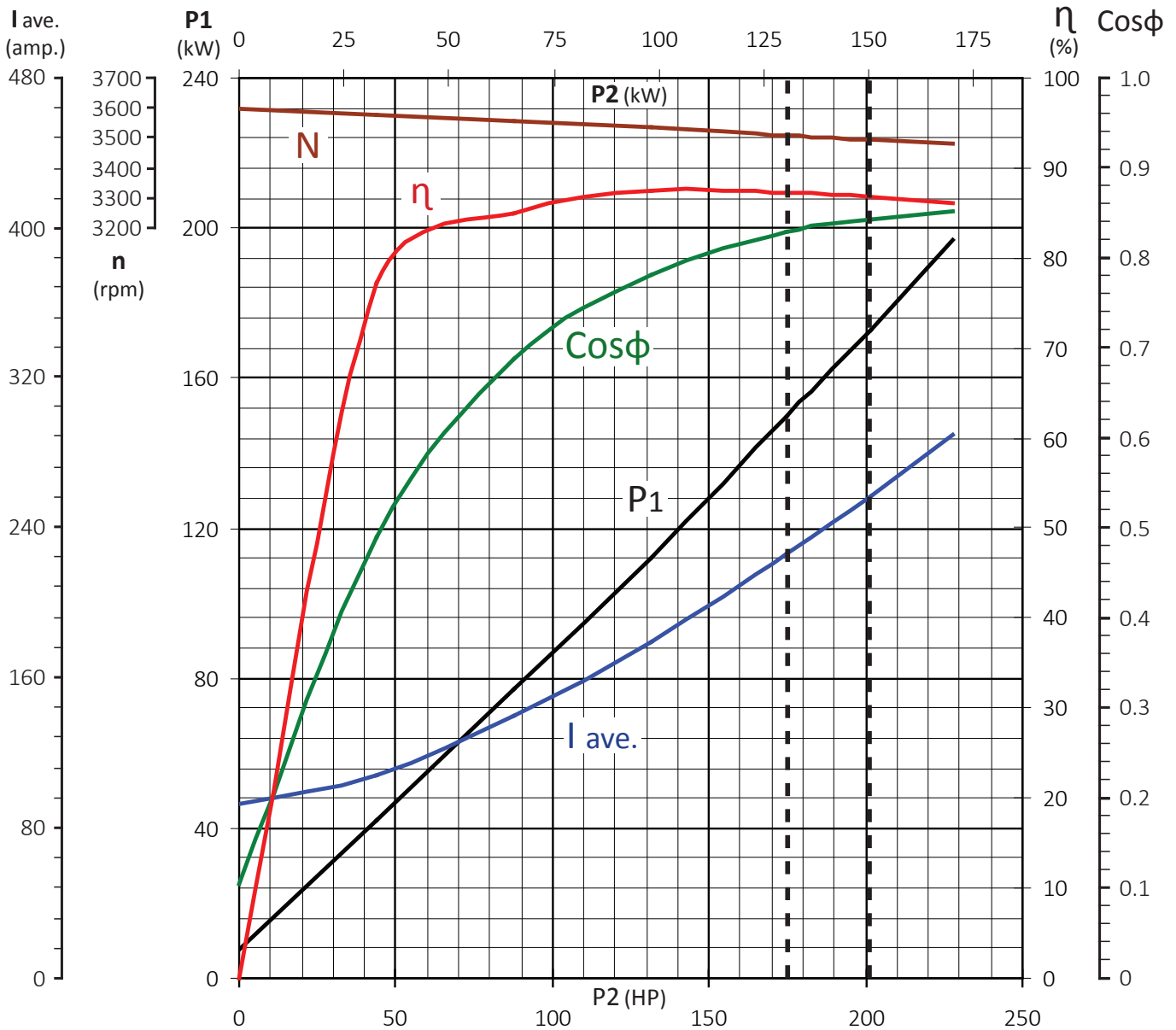

Load	Frequency Hz	Volt ave. V	I ave. A	P1 kW	P1 HP	RPM	Torque Nm	P2 kW	P2 HP	Efficiency %	Cos pi
0%	60.00	460.0	93.12	7.79	10.44	3597.6	0.00	0.00	0.00	0.00%	0.105
25%	60.00	460.0	108.40	42.32	56.73	3578.2	87.10	32.64	43.75	77.12%	0.490
50%	60.00	460.0	140.02	76.86	103.03	3557.4	175.22	65.28	87.50	84.93%	0.689
75%	60.00	460.0	179.85	112.05	150.20	3535.3	264.48	97.91	131.25	87.38%	0.782
100%	60.00	460.0	226.41	149.54	200.46	3509.6	355.21	130.55	175.00	87.30%	0.829
115%	60.00	460.0	257.25	172.78	231.61	3493.9	410.34	150.13	201.25	86.89%	0.843
130%	60.00	460.0	290.29	197.05	264.14	3478.5	465.90	169.72	227.50	86.13%	0.852

Motor Performance Curve

200 HP | 150 kW | 460 Volt | 60 Hertz | 2 Pole

tolerances according to NEMA standard and IEC 60034-1

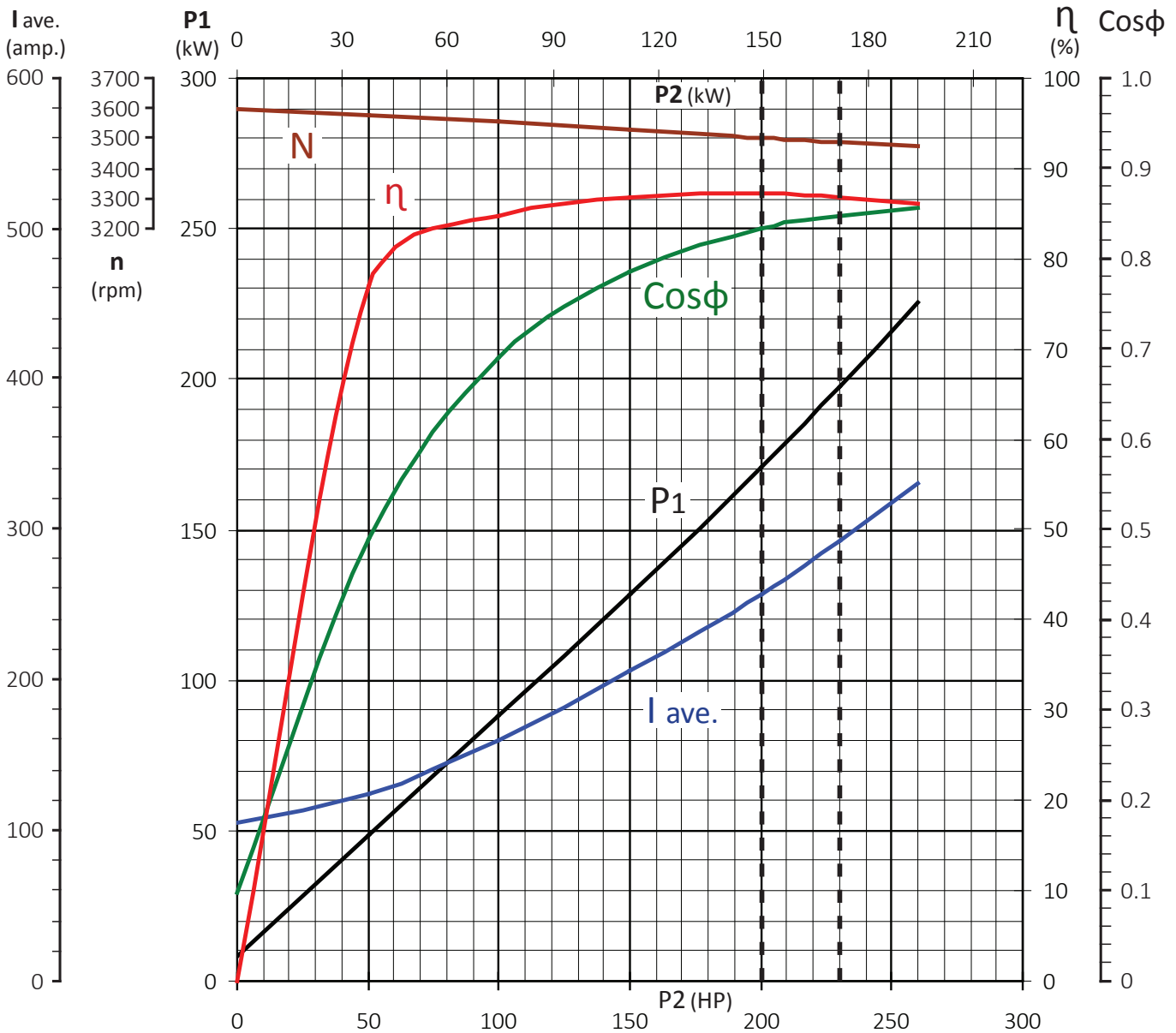

10" 60 HZ SERIES

Load	Frequency Hz	Volt ave. V	I ave. A	P1 kW	P1 HP	RPM	Torque Nm	P2 kW	P2 HP	Efficiency %	Cos pi
0%	60.00	460.0	105.15	8.21	11.01	3596.3	0.00	0.00	0.00	0.00%	0.098
25%	60.00	460.0	124.51	48.51	65.03	3576.6	99.59	37.30	50.00	76.89%	0.489
50%	60.00	460.0	160.11	88.02	117.99	3555.2	200.38	74.60	100.00	84.75%	0.690
75%	60.00	460.0	205.91	128.78	172.63	3531.8	302.56	111.90	150.00	86.89%	0.785
100%	60.00	460.0	257.56	171.14	229.41	3504.8	406.52	149.20	200.00	87.18%	0.834
115%	60.00	460.0	292.74	197.78	265.12	3488.6	469.66	171.58	230.00	86.75%	0.848
130%	60.00	460.0	330.58	225.45	302.21	3471.4	533.56	193.96	260.00	86.03%	0.856

Motor Performance Curve

tolerances according to NEMA standard and IEC 60034-1

250 HP | **187** kW | **460** Volt | **60** Hertz | **2** Pole

10" 60 HZ SERIES

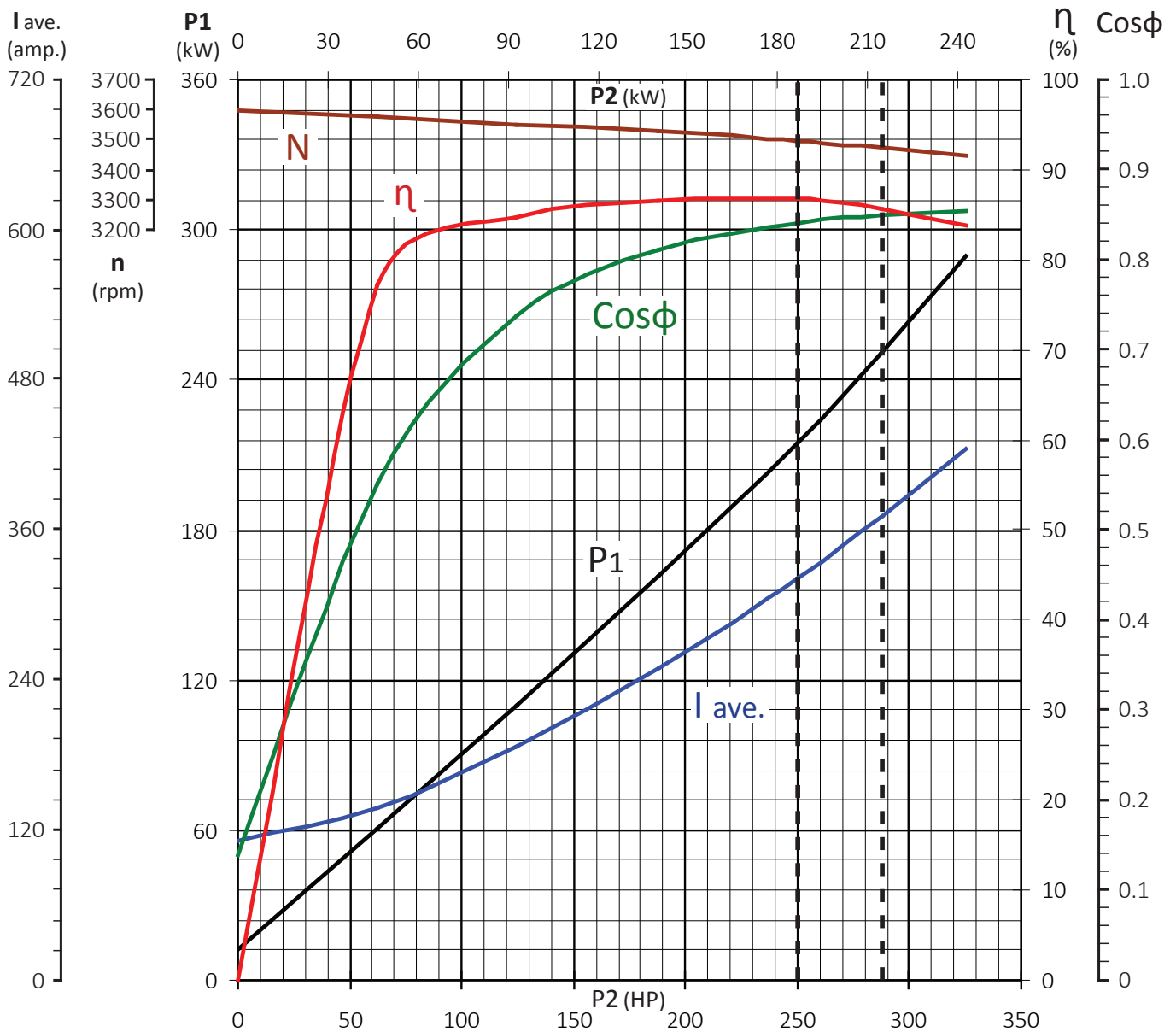

Load	Frequency Hz	Volt ave. V	I ave. A	P1 kW	P1 HP	RPM	Torque Nm	P2 kW	P2 HP	Efficiency %	Cos pi
0%	60.00	460.0	111.43	12.34	16.54	3597.5	0.00	0.00	0.00	0.00%	0.139
25%	60.00	460.0	137.61	60.41	80.98	3576.0	124.51	46.63	62.50	77.18%	0.551
50%	60.00	460.0	187.29	110.12	147.61	3552.1	250.69	93.25	125.00	84.68%	0.738
75%	60.00	460.0	249.61	161.48	216.46	3526.7	378.74	139.88	187.50	86.62%	0.812
100%	60.00	460.0	321.44	215.12	288.36	3495.3	509.53	186.50	250.00	86.70%	0.840
115%	60.00	460.0	370.66	250.72	336.09	3475.4	589.31	214.48	287.50	85.54%	0.849
130%	60.00	460.0	424.46	289.14	387.59	3449.9	671.10	242.45	325.00	83.85%	0.855

Motor Performance Curve

tolerances according to NEMA standard and IEC 60034-1

270 HP | **201** kW | **460** Volt | **60** Hertz | **2** Pole

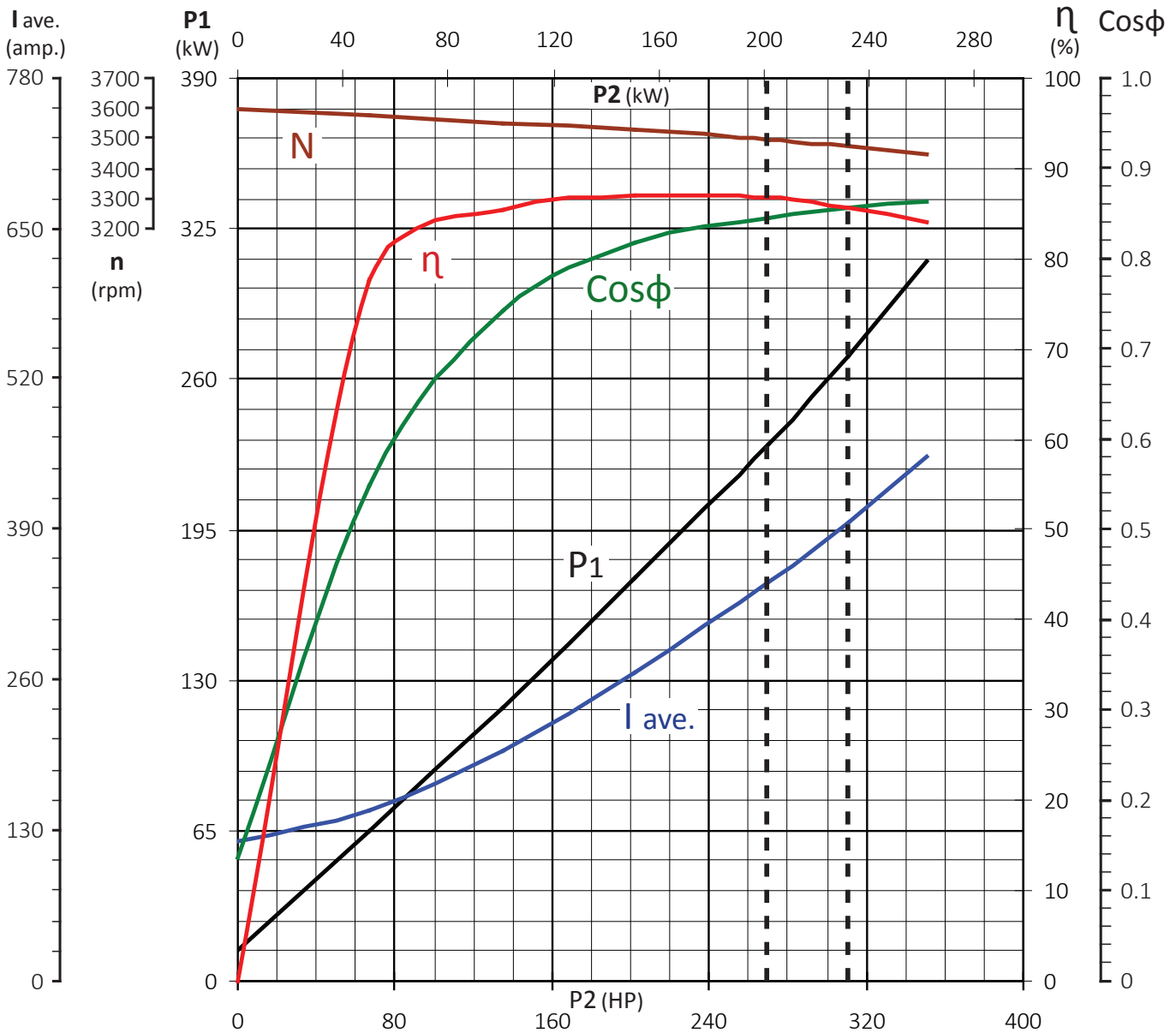

10" 60 HZ SERIES

Load	Frequency Hz	Volt ave. V	I ave. A	P1 kW	P1 HP	RPM	Torque Nm	P2 kW	P2 HP	Efficiency %	Cos pi
0%	60.00	460.0	120.75	13.18	17.67	3596.7	0.00	0.00	0.00	0.00%	0.137
25%	60.00	460.0	148.10	64.78	86.84	3574.1	134.54	50.36	67.50	77.73%	0.549
50%	60.00	460.0	199.69	118.05	158.24	3552.1	270.75	100.71	135.00	85.31%	0.742
75%	60.00	460.0	266.88	173.72	232.87	3525.8	409.15	151.07	202.50	86.96%	0.817
100%	60.00	460.0	344.28	232.05	311.06	3494.8	550.37	201.42	270.00	86.80%	0.846
115%	60.00	460.0	395.80	270.25	362.27	3474.8	636.56	231.63	310.50	85.71%	0.857
130%	60.00	460.0	452.29	311.34	417.35	3449.4	724.90	261.85	351.00	84.10%	0.864

Motor Performance Curve

tolerances according to NEMA standard and IEC 60034-1

75 HP | **56** kW | **380** Volt | **50** Hertz | **2** Pole

10" 50 HZ SERIES

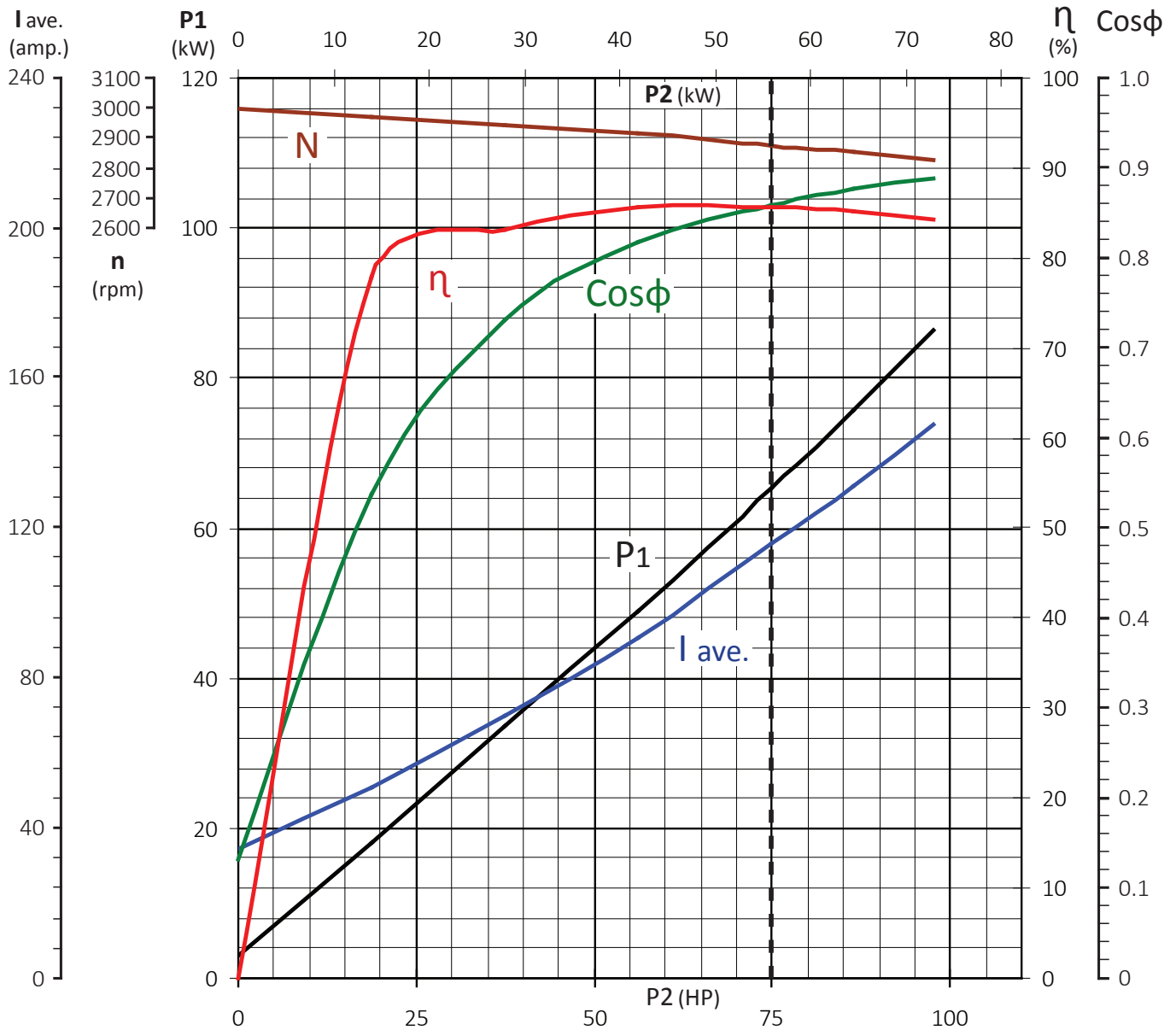

Load	Frequency Hz	Volt ave. V	I ave. A	P1 kW	P1 HP	RPM	Torque Nm	P2 kW	P2 HP	Efficiency %	Cos pi
0%	50.00	380.0	34.39	3.01	4.03	2997.2	0.00	0.00	0.00	0.00%	0.133
25%	50.00	380.0	50.75	17.97	24.09	2971.3	44.95	13.99	18.75	77.84%	0.538
50%	50.00	380.0	69.85	33.65	45.11	2943.8	90.75	27.98	37.50	83.14%	0.732
75%	50.00	380.0	90.98	48.98	65.66	2912.6	137.58	41.96	56.25	85.67%	0.818
100%	50.00	380.0	115.74	65.36	87.61	2875.1	185.83	55.95	75.00	85.60%	0.858
115%	50.00	380.0	131.11	75.59	101.33	2850.7	215.53	64.34	86.25	85.12%	0.876
130%	50.00	380.0	147.58	86.25	115.62	2825.1	245.85	72.74	97.50	84.33%	0.888

Motor Performance Curve

tolerances according to NEMA standard and IEC 60034-1

100 HP | **74.6** kW | **380** Volt | **50** Hertz | **2** Pole

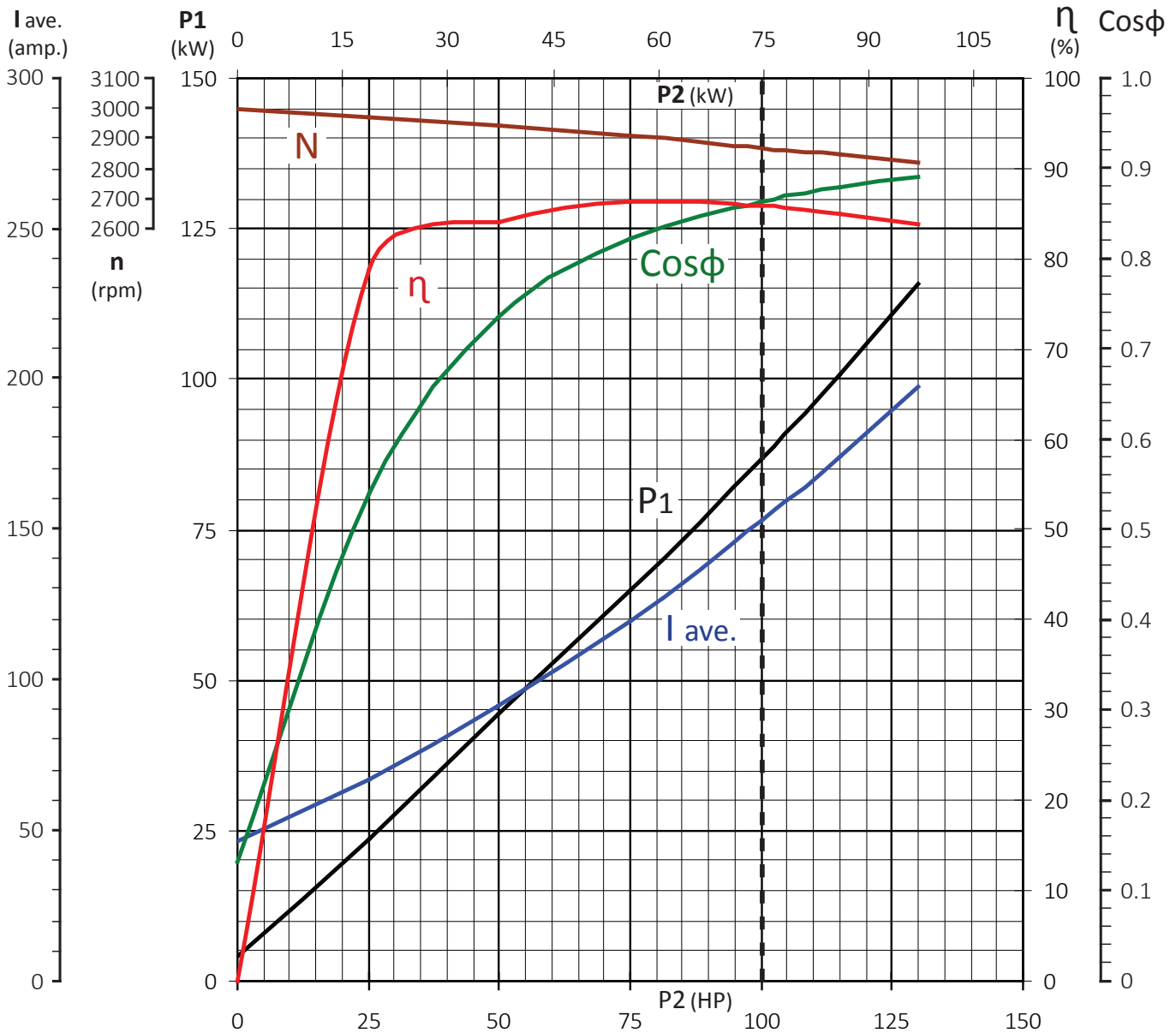

10" 50 HZ SERIES

Load	Frequency Hz	Volt ave. V	I ave. A	P1 kW	P1 HP	RPM	Torque Nm	P2 kW	P2 HP	Efficiency %	Cos pi
0%	50.00	380.0	46.63	4.02	5.39	2996.9	0.00	0.00	0.00	0.00%	0.131
25%	50.00	380.0	66.65	23.69	31.75	2969.6	59.97	18.65	25.00	78.73%	0.540
50%	50.00	380.0	91.53	44.34	59.44	2941.0	121.11	37.30	50.00	84.12%	0.736
75%	50.00	380.0	119.69	64.75	86.80	2907.7	183.75	55.95	75.00	86.41%	0.822
100%	50.00	380.0	153.07	86.94	116.55	2870.2	248.19	74.60	100.00	85.80%	0.863
115%	50.00	380.0	174.43	100.91	135.27	2844.3	288.03	85.79	115.00	85.01%	0.879
130%	50.00	380.0	197.43	115.78	155.20	2816.7	328.78	96.98	130.00	83.77%	0.891

Motor Performance Curve

tolerances according to NEMA standard and IEC 60034-1

125 HP | **93** kW | **380** Volt | **50** Hertz | **2** Pole

10" 50 HZ SERIES

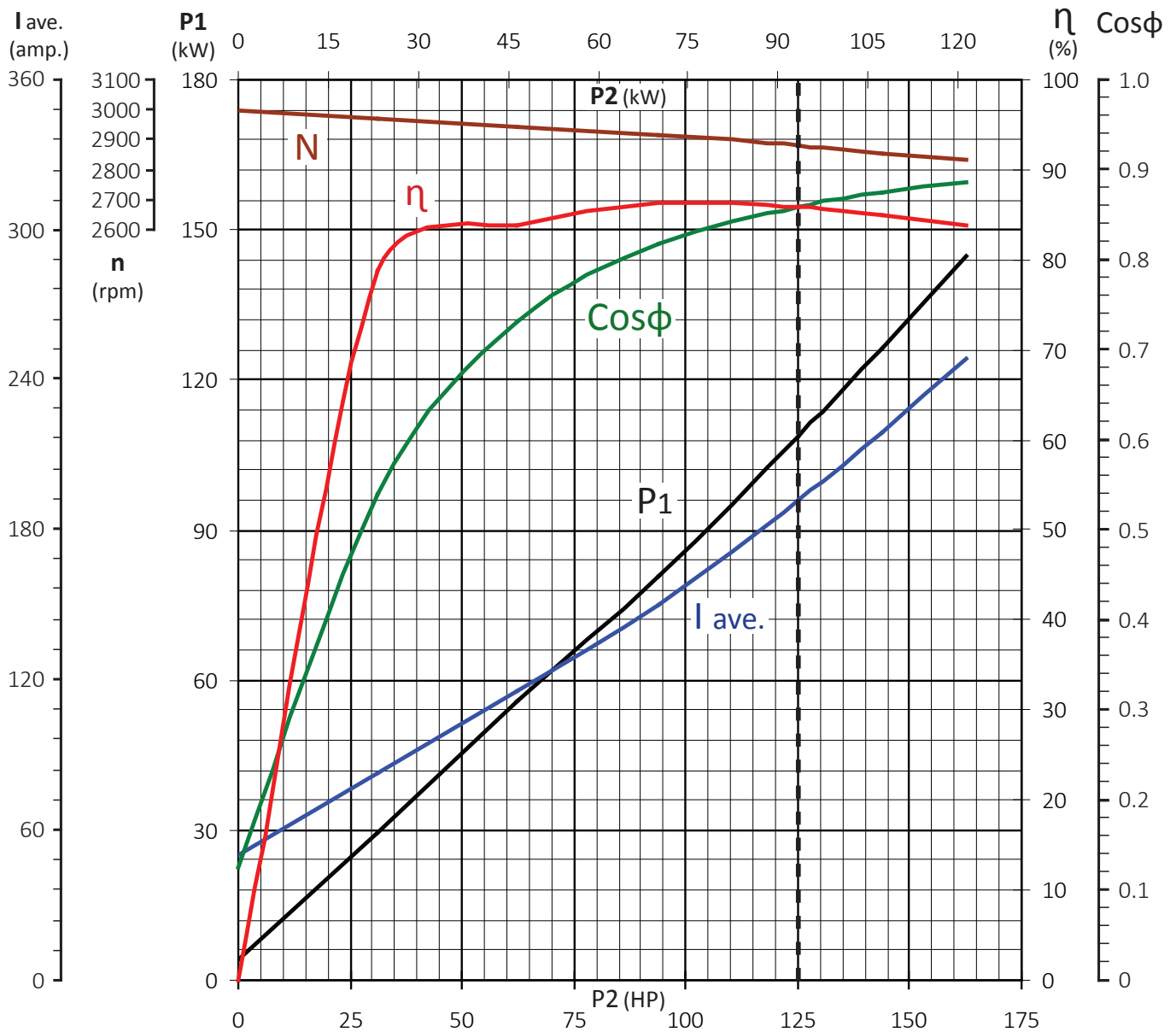

Load	Frequency Hz	Volt ave. V	I ave. A	P1 kW	P1 HP	RPM	Torque Nm	P2 kW	P2 HP	Efficiency %	Cos pi
0%	50.00	380.0	50.32	4.14	5.55	2996.9	0.00	0.00	0.00	0.00%	0.125
25%	50.00	380.0	83.16	29.61	39.69	2971.7	74.91	23.31	31.25	78.73%	0.541
50%	50.00	380.0	115.32	55.56	74.48	2945.2	151.17	46.63	62.50	83.92%	0.732
75%	50.00	380.0	150.34	80.94	108.50	2914.4	229.16	69.94	93.75	86.41%	0.818
100%	50.00	380.0	192.23	108.68	145.68	2879.8	309.22	93.25	125.00	85.80%	0.859
115%	50.00	380.0	219.03	126.14	169.09	2855.7	358.59	107.24	143.75	85.01%	0.875
130%	50.00	380.0	248.18	144.72	193.99	2830.3	409.01	121.23	162.50	83.77%	0.886

Motor Performance Curve

tolerances according to NEMA standard and IEC 60034-1

150 HP | **112** kW | **380** Volt | **50** Hertz | **2** Pole

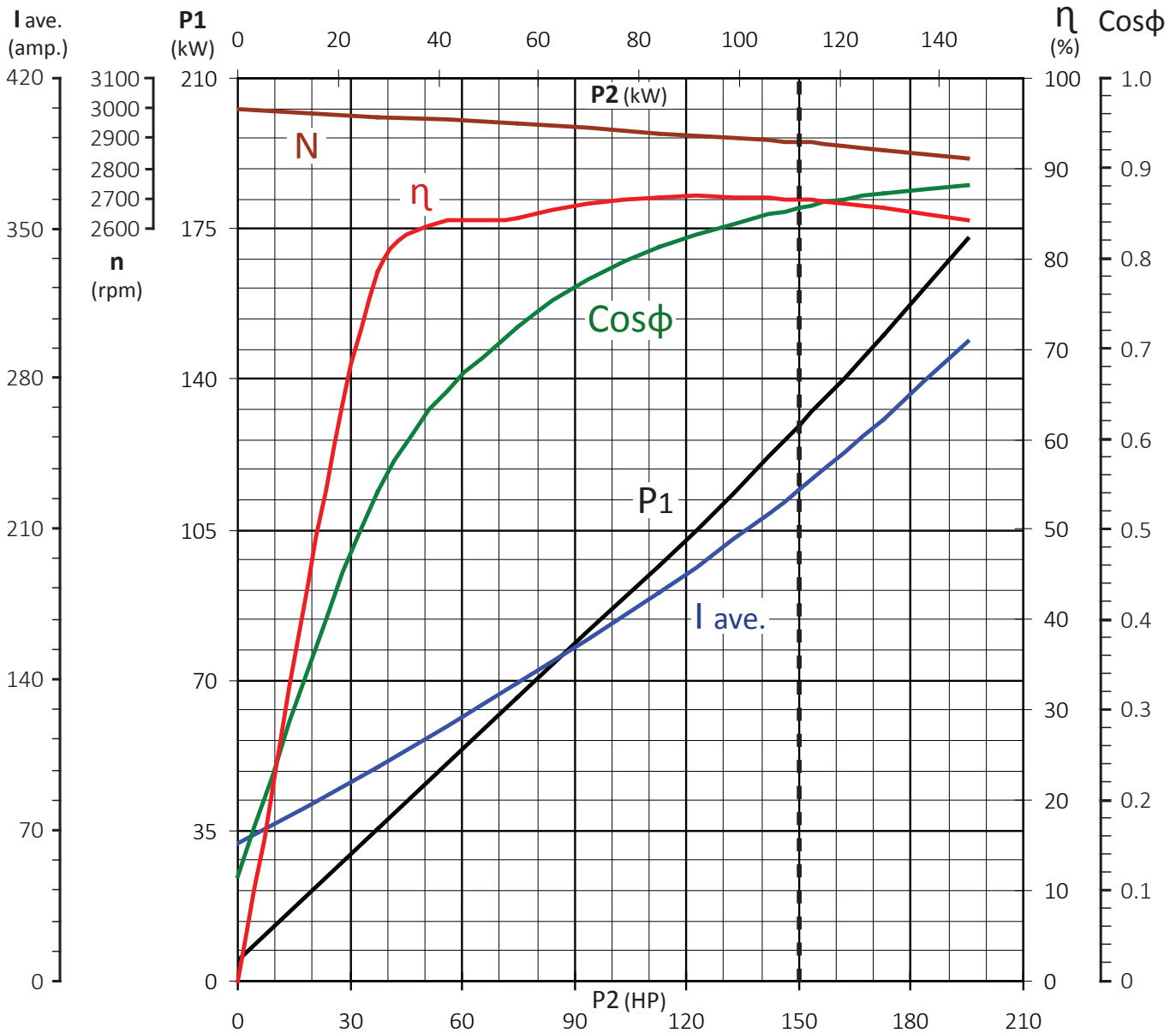

10" 50 HZ SERIES

Load	Frequency Hz	Volt ave. V	I ave. A	P1 kW	P1 HP	RPM	Torque Nm	P2 kW	P2 HP	Efficiency %	Cos pi
0%	50.00	380.0	64.18	4.90	6.57	2996.9	0.00	0.00	0.00	0.00%	0.116
25%	50.00	380.0	99.67	35.62	47.75	2972.5	89.87	27.98	37.50	78.54%	0.543
50%	50.00	380.0	138.69	66.18	88.71	2948.4	181.21	55.95	75.00	84.54%	0.725
75%	50.00	380.0	180.49	96.58	129.46	2918.5	274.60	83.93	112.50	86.90%	0.813
100%	50.00	380.0	229.03	129.18	173.16	2885.2	370.36	111.90	150.00	86.62%	0.857
115%	50.00	380.0	261.57	150.12	201.23	2861.7	429.42	128.69	172.50	85.72%	0.872
130%	50.00	380.0	297.25	172.55	231.30	2836.6	489.72	145.47	195.00	84.31%	0.882

Motor Performance Curve

tolerances according to NEMA standard and IEC 60034-1

175 HP | **131** kW | **380** Volt | **50** Hertz | **2** Pole

10" 50 HZ SERIES

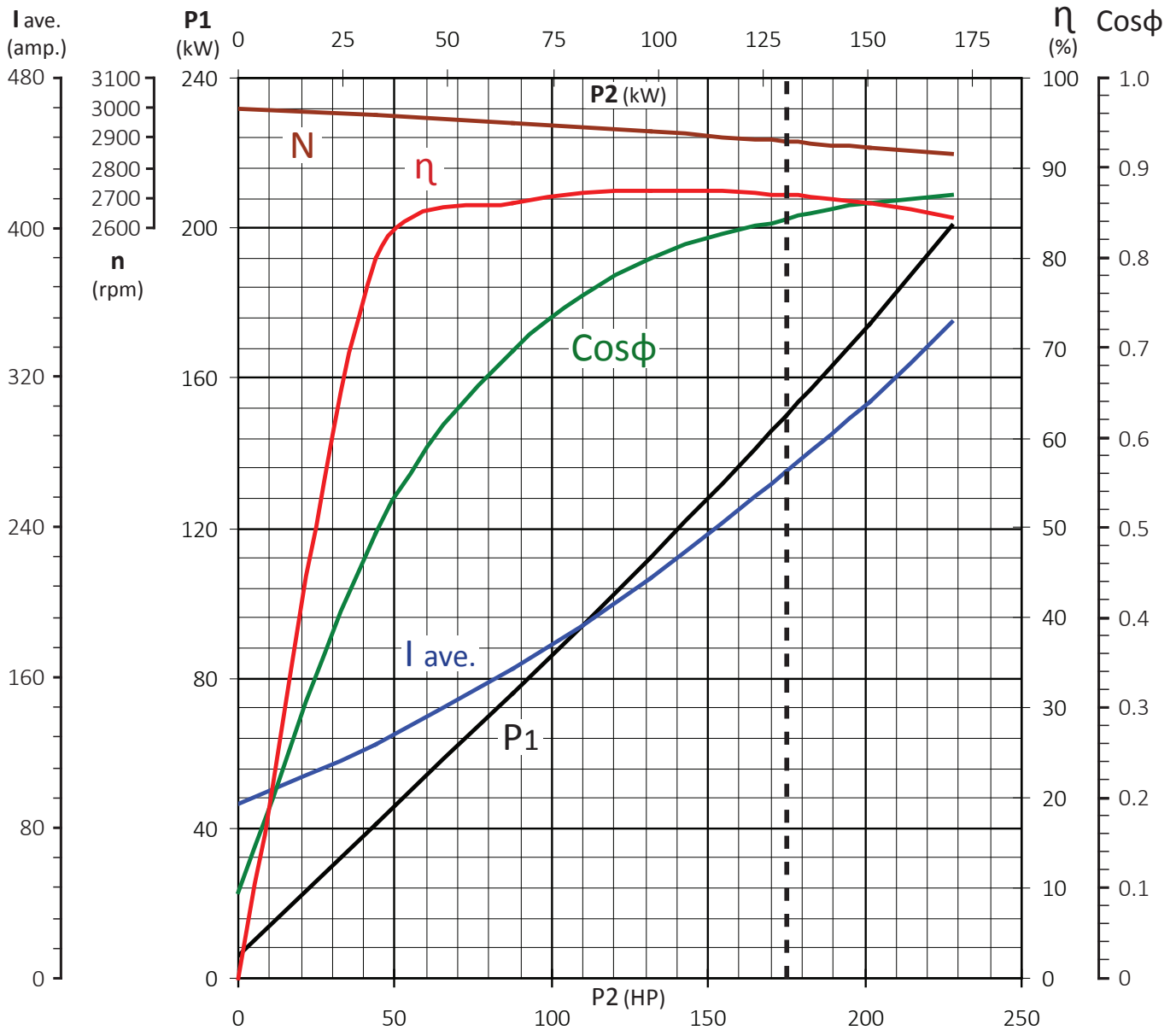

Load	Frequency Hz	Volt ave. V	I ave. A	P1 kW	P1 HP	RPM	Torque Nm	P2 kW	P2 HP	Efficiency %	Cos pi
0%	50.00	380.0	92.76	5.80	7.77	2997.1	0.00	0.00	0.00	0.00%	0.095
25%	50.00	380.0	125.17	40.78	54.66	2974.9	104.77	32.64	43.75	80.03%	0.495
50%	50.00	380.0	165.13	75.86	101.69	2951.3	211.21	65.28	87.50	86.05%	0.698
75%	50.00	380.0	213.08	112.05	150.20	2921.9	319.99	97.91	131.25	87.38%	0.799
100%	50.00	380.0	270.08	149.85	200.87	2890.3	431.33	130.55	175.00	87.12%	0.843
115%	50.00	380.0	307.55	174.28	233.62	2867.8	499.92	150.13	201.25	86.14%	0.861
130%	50.00	380.0	350.30	200.58	268.87	2843.8	569.89	169.72	227.50	84.61%	0.870

Motor Performance Curve

200 HP | 150 kW | 380 Volt | 50 Hertz | 2 Pole

tolerances according to NEMA standard and IEC 60034-1

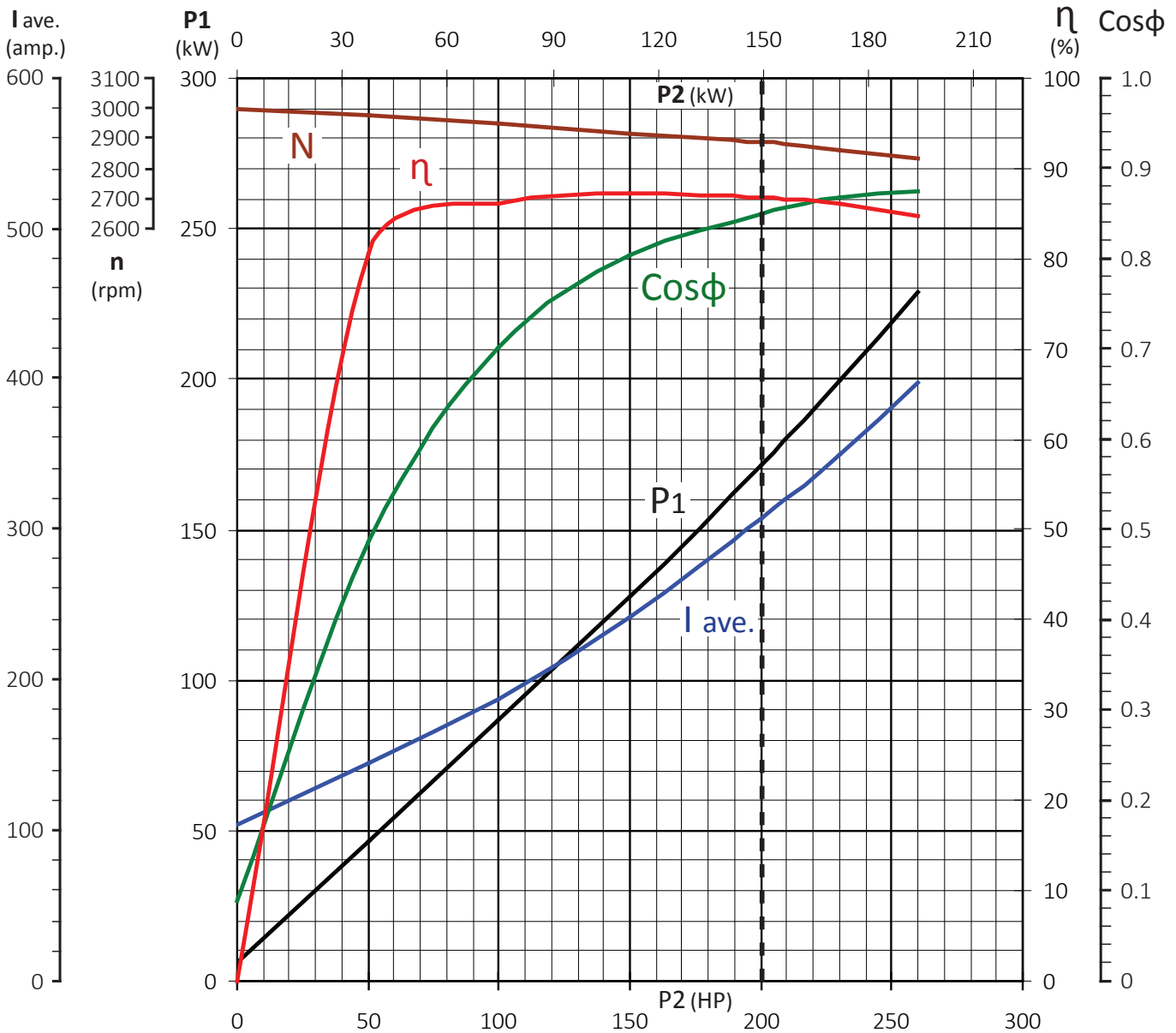

10" 50 HZ SERIES

Load	Frequency Hz	Volt ave. V	I ave. A	P1 kW	P1 HP	RPM	Torque Nm	P2 kW	P2 HP	Efficiency %	Cos pi
0%	50.00	380.0	104.48	6.12	8.20	2997.2	0.00	0.00	0.00	0.00%	0.089
25%	50.00	380.0	144.23	46.23	61.97	2974.0	119.77	37.30	50.00	80.68%	0.487
50%	50.00	380.0	187.48	86.62	116.11	2947.8	241.67	74.60	100.00	86.12%	0.702
75%	50.00	380.0	242.12	128.12	171.74	2918.9	366.08	111.90	150.00	87.34%	0.804
100%	50.00	380.0	307.31	171.72	230.19	2885.1	493.83	149.20	200.00	86.89%	0.849
115%	50.00	380.0	349.53	199.45	267.36	2861.5	572.58	171.58	230.00	86.03%	0.867
130%	50.00	380.0	397.16	228.72	306.60	2836.3	653.04	193.96	260.00	84.80%	0.875

Motor Performance Curve

tolerances according to NEMA standard and IEC 60034-1

250 HP | **187** kW | **380** Volt | **50** Hertz | **2** Pole

10" 50 HZ SERIES

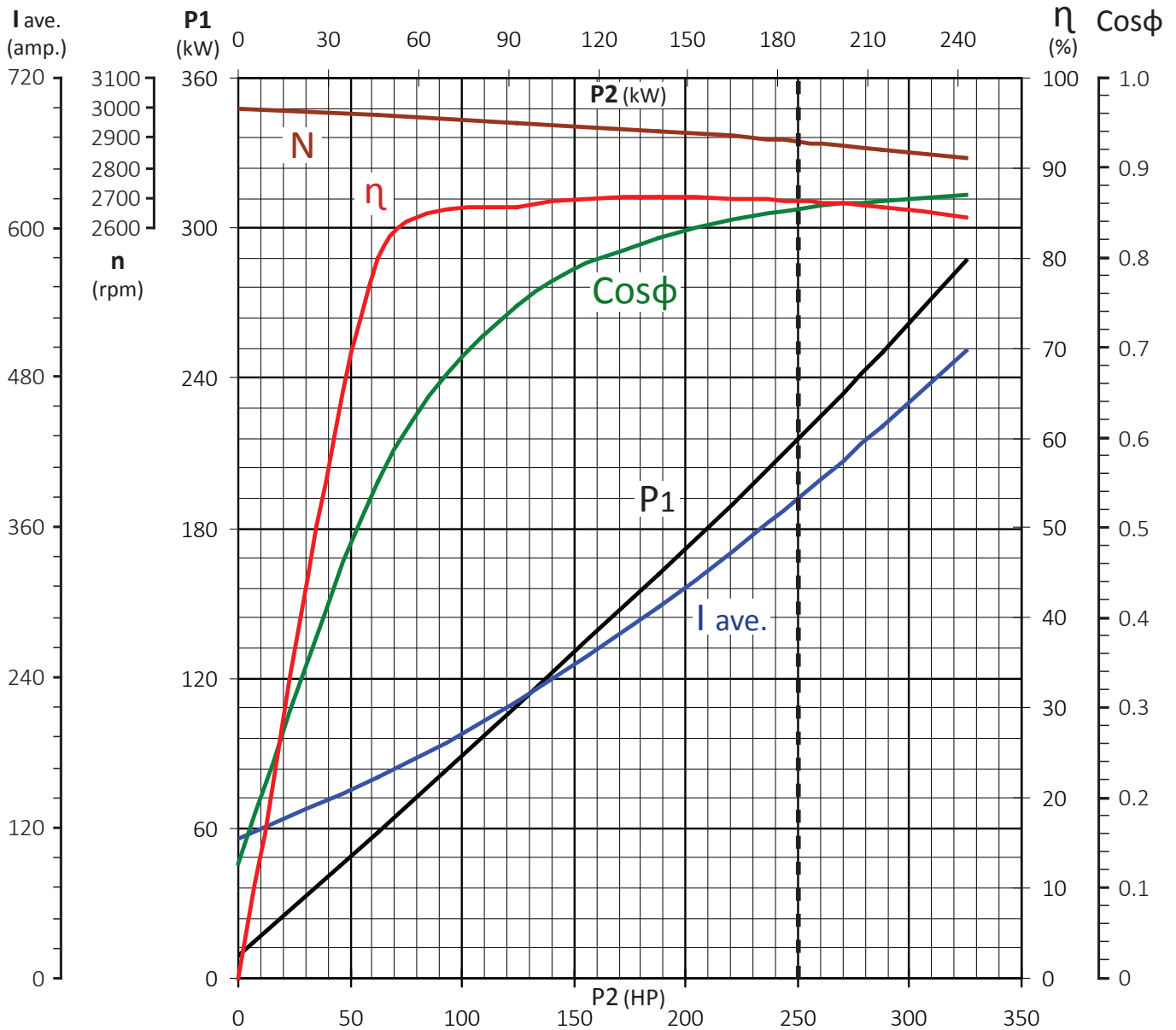

Load	Frequency Hz	Volt ave. V	I ave. A	P1 kW	P1 HP	RPM	Torque Nm	P2 kW	P2 HP	Efficiency %	Cos pi
0%	50.00	380.0	110.90	9.27	12.43	2997.7	0.00	0.00	0.00	0.00%	0.127
25%	50.00	380.0	160.60	58.24	78.07	2973.9	149.71	46.63	62.50	80.06%	0.551
50%	50.00	380.0	221.60	108.95	146.05	2947.3	302.13	93.25	125.00	85.59%	0.747
75%	50.00	380.0	297.56	161.18	216.06	2919.7	457.48	139.88	187.50	86.78%	0.823
100%	50.00	380.0	384.38	216.05	289.61	2885.2	617.26	186.50	250.00	86.32%	0.854
115%	50.00	380.0	440.43	250.45	335.72	2863.4	715.26	214.48	287.50	85.64%	0.864
130%	50.00	380.0	501.62	287.23	385.03	2835.5	816.51	242.45	325.00	84.41%	0.870

Technical DETAILS

Motor Dimensions and Weights

Motor Type	Motor Size		L Motor Length (inch)	L1 Motor Length (inch)	Packing Dimension W x H x L (inch)	Weight (Lbs)	
	HP	kW				Without Packing	With Packing
10SME 075-2	75	56	50.6	46.6	14.3 x 17.8 x 56.6	395	435
10SME 100-2	100	75	60.5	56.5	14.3 x 17.8 x 66.5	652	713
10SME 125-2	125	93	60.5	56.5	14.3 x 17.8 x 66.5	652	713
10SME 150-2	150	112	64.4	60.4	14.3 x 17.8 x 70.4	730	792
10SME 175-2	175	130	72.3	68.3	14.3 x 17.8 x 76.6	824	889
10SME 200-2	200	150	72.3	68.3	14.3 x 17.8 x 76.6	824	889
10SME 250-2	250	186	80.1	76.1	14.3 x 17.8 x 86.1	945	1020
10SME 270-2	270	200	84.1	80.1	14.3 x 17.8 x 90.1	1180	1250

DOL

SD

10SME 075-2	75	56	50.6	46.6	14.3 x 17.8 x 56.6	415	463
10SME 100-2	100	75	60.5	56.5	14.3 x 17.8 x 66.5	681	742
10SME 125-2	125	93	60.5	56.5	14.3 x 17.8 x 66.5	681	742
10SME 150-2	150	112	64.4	60.4	14.3 x 17.8 x 70.4	759	822
10SME 175-2	175	130	72.3	68.3	14.3 x 17.8 x 76.6	853	918
10SME 200-2	200	150	72.3	68.3	14.3 x 17.8 x 76.6	853	918
10SME 250-2	250	186	80.1	76.1	14.3 x 17.8 x 86.1	974	1049
10SME 270-2	270	200	84.1	80.1	14.3 x 17.8 x 90.1	1209	1279

Note: For 10SME motor with 10"x10" Keyed Shaft

* = One (1) inch length increased in "L".

* = Weight increased by Sixteen (16) Lbs.

10" x 8" NEMA Spline Shaft

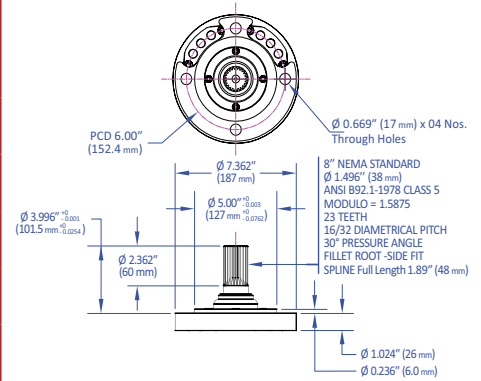

10" x 10" Key way Shaft

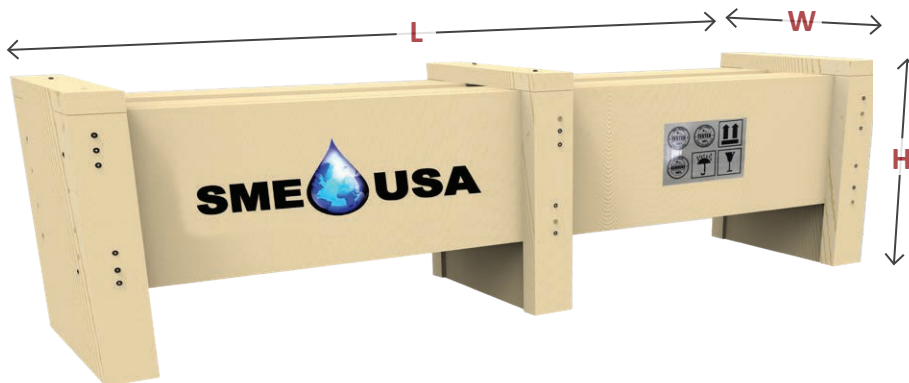
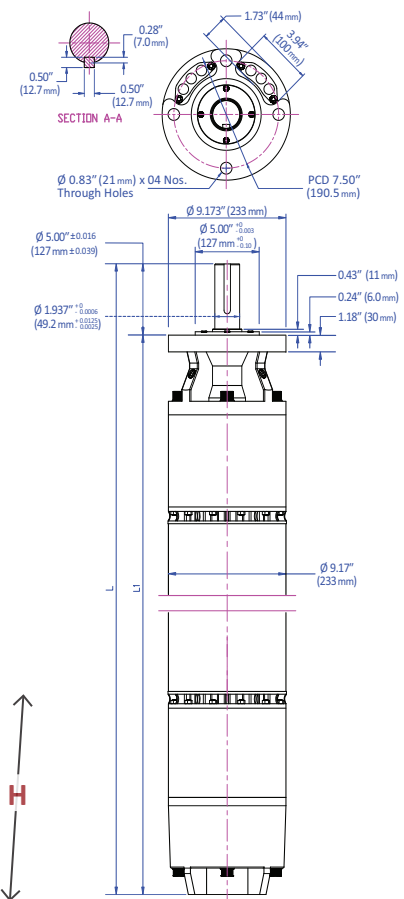

10" SERIES

Exploded VIEW

Cross-Sectional VIEW

10" SERIES

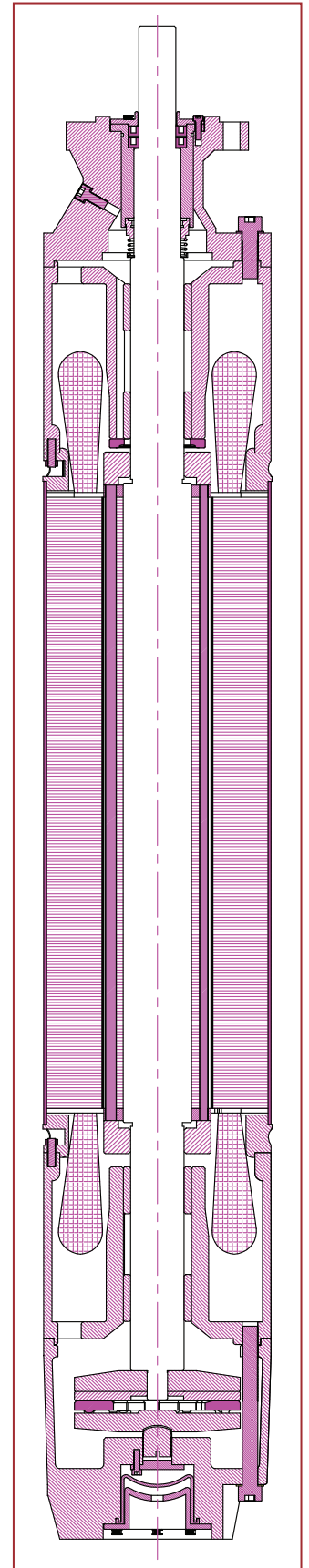
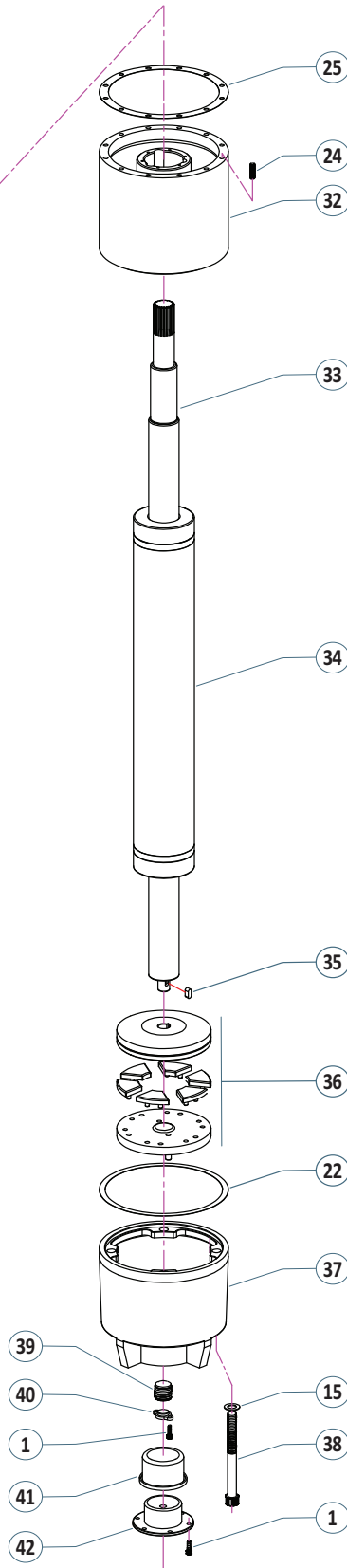
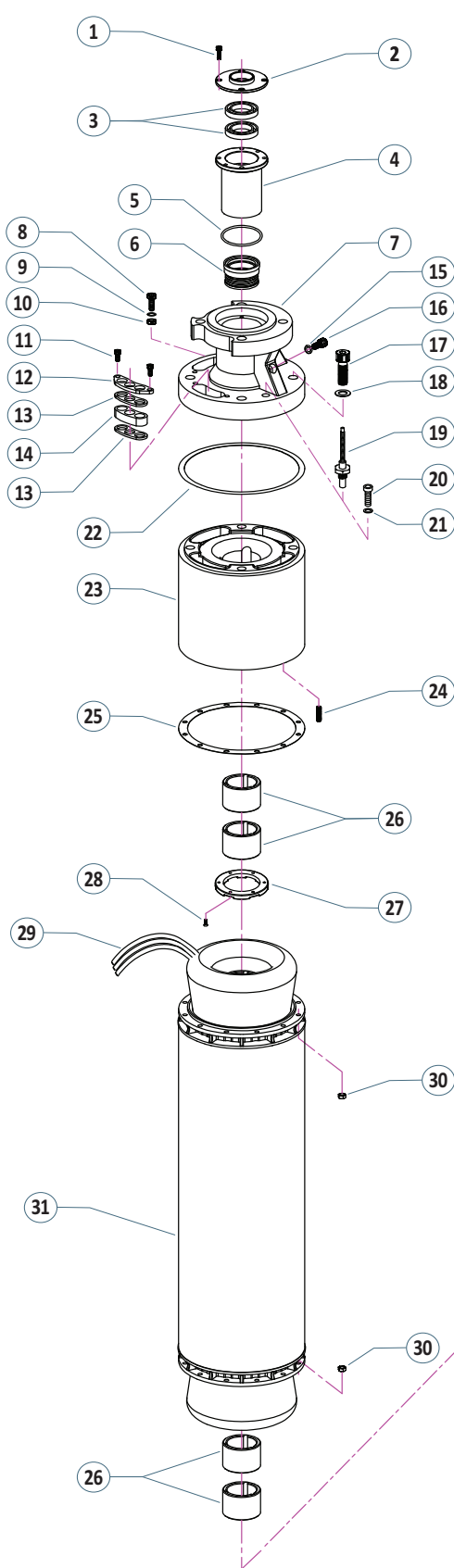

Parts LIST with Material & Quantity

Pos.	Item Code	Part Name	Material	Qty	Unit
1	60161252	Bolt Allen M6 x 20	Stainless Steel	12	Nr
2	60161085	Mechanical Seal Cover	Stainless Steel	1	Nr
3	60161127	Oil Seal 38x60x10	NBR	2	Nr
4	60161125	Bush Seal Support	Cast Iron	1	Nr
5	60161115	O-Ring 65x2,5	NBR	1	Nr
6	60161275	Mechanical Seal Complete	Silicon Tungsten Carbide (WC) + NBR + Stainless Steel	1	Nr
7	60271000	Top Piece / Upper Support Double Flange	Cast Iron	1	Nr
8	60161254	Bolt Allen M8 x 35	Stainless Steel	1	Nr
9	60161263	Spring Washer M8	Stainless Steel	1	Nr
10	60161262	Nut Hex M8	Stainless Steel	1	Nr
11	60161253	Bolt Allen M8 x 25	Stainless Steel	2	Nr
12	60161150	Cable Top Cover Plate	Carbon Steel	2	Nr
13	60271165	Washer nylon	Nylon	2	Nr
14	60271180	Gasket Rubber	NBR	1	Nr
15	60101157	Washer Bonded / Dowty Seal M10	NBR / Stainless Steel AISI 316	2	Nr
16	60101068	Bolt Allen M10 x 16	Stainless Steel	2	Nr
17	60161255	Bolt Allen M16 x 75	Stainless Steel	4	Nr
18	60161272	Washer Bonded / Dowty Seal M16	NBR / Stainless Steel AISI 316	8	Nr
19	60101485	PT 100 Sensor	Stainless Steel	1	Nr
20	60161250	Bolt Allen M8x20	Stainless Steel	14	Nr
21	60161267	Washer Bonded / Dowty Seal M8	NBR / Stainless Steel AISI 316	1	Nr
22	60271150	Gasket Upper & Lower	Tesnit	2	Nr
23	60161080	Upper Bearing Housing	Cast Iron	1	Nr
24	60271170	Stud Bolt M8x35	Stainless Steel	24	Nr
25	60271152	Gasket Stator	Tesnit	2	Nr
26	60271100	Carbon Bush	Carbon	4	Nr
27	60271030	Upper Thrust Bearing	Brass	1	Nr
28	60101142	Screw CSK M4x10	Stainless Steel	6	Nr
29A	601011XX	Motor Lead Cable (1 x 25/ 35/ 50/ 70/ 95 mm ²)	Copper + Rubber	48	Ft
29B	60101185	Cable for Earth 1 x 12 mm ²	Copper + PVC	16	Ft
30	60161262	Nut Hex M8	Stainless Steel	24	Nr
31	602712XX	Stator Stack (Assembly)	Silicon Steel (50C800) + SS304	1	Set
32	60271040	Lower Bearing Housing	Cast Iron	1	Nr
33	602713XX	Rotor Shaft	Stainless Steel (SS431)	1	Nr
34	60271330	Rotor Lamination (Including Shaft + Copper Bars+ End Ring)	Silicon Steel (50C800) + Stainless Steel + Copper	1	Set
35	60101145	Key for End Shaft	Stainless Steel	1	Nr
36	60271050	Thrust Bearing Complete	Stainless Steel / Carbon	1	Set
37	60271020	Thrust Support	Cast Iron	1	Nr
38	60271142	Bolt Allen M16x180	Stainless Steel	4	Nr
39	60271140	Adjustment Bolt	Stainless Steel	1	Nr
40	60161010	Lock Washer Adj. Bolt	MS	1	Nr
41	60271130	Diaphragm Rubber	NBR	1	Nr
42	60271135	Diaphragm Support	Cast Iron	1	Nr

10" SERIES

Thrust Bearing

Bearing Model	TB77S4
Capacity	6000 Lbs (26.7 kN)
Application (Standard)	6SME 5.5 HP to 50 HP
No. of Segments	4 Nrs
Segment Area	550 mm ² (0.853 in ²)
Total Contact Area	2200 mm ² (3.41 in ²)
Carbon Pad OD	77 mm (3.031 in)
Carbon Pad ID	31.5 mm (1.24 in)
Bearing Height	57.5 mm (2.264 in)

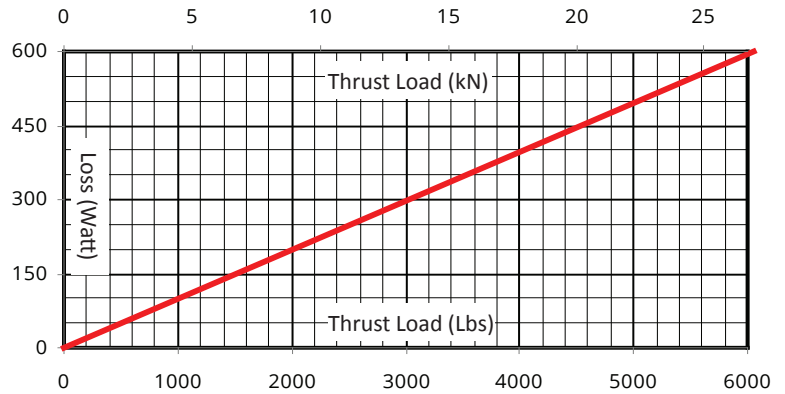
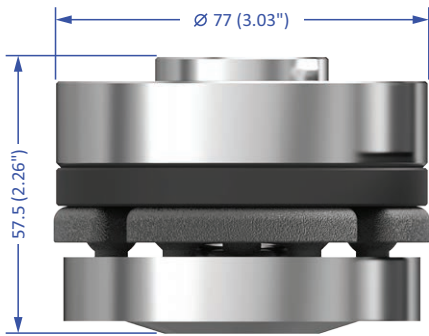
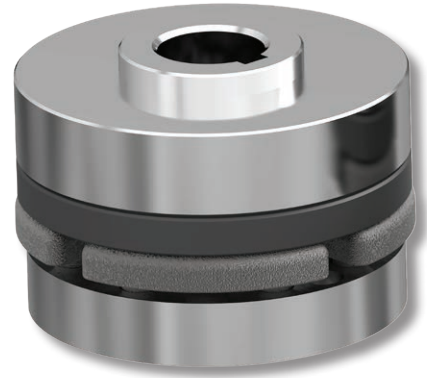

Bearing Model	TB110S5
Capacity	13849 Lbs (61.6 kN)
Application (Standard)	6SME 60 HP to 75 HP
No. of Segments	5 Nrs
Segment Area	858 mm ² (1.33 in ²)
Total Contact Area	4290 mm ² (6.65 in ²)
Carbon Pad OD	109.5 mm (4.311 in)
Carbon Pad ID	51.8 mm (2.039 in)
Bearing Height	55 mm (2.165 in)

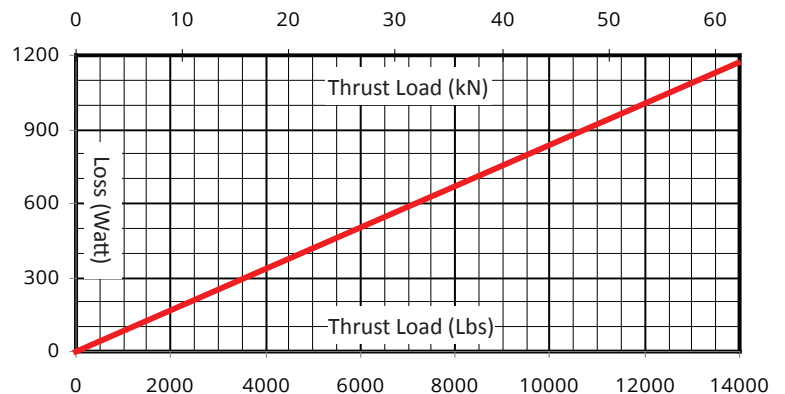
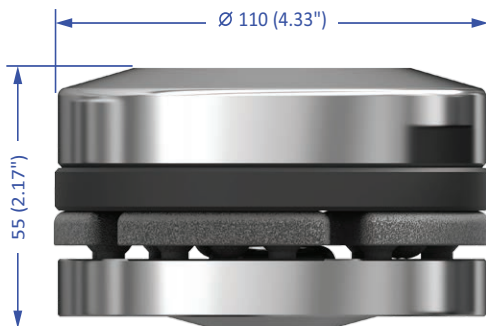
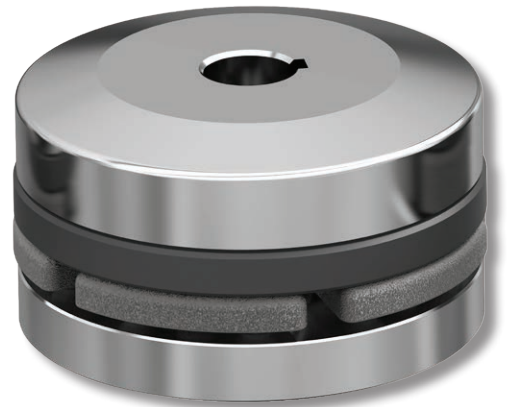

Bearing Model	TB138S6
Capacity	18000 Lbs (80.1 kN)
Application (Standard)	8SME 40 HP to 200 HP
No. of Segments	6 Nrs
Segment Area	1380 mm ² (2.139 in ²)
Total Contact Area	8280 mm ² (12.834 in ²)
Carbon Pad OD	136 mm (5.354 in)
Carbon Pad ID	54 mm (2.126 in)
Bearing Height	68 mm (2.677 in)

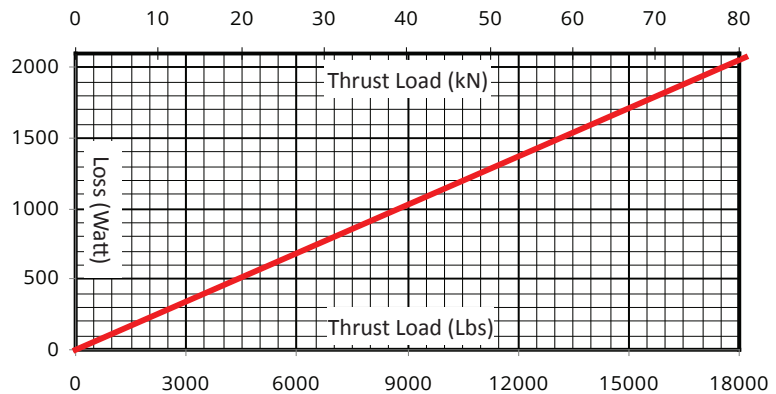
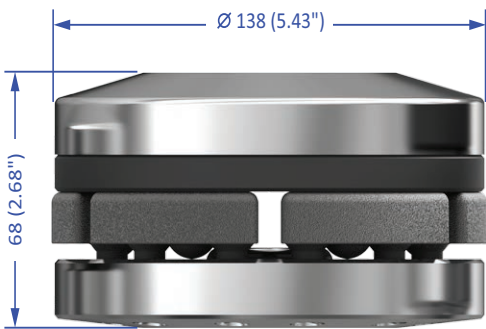
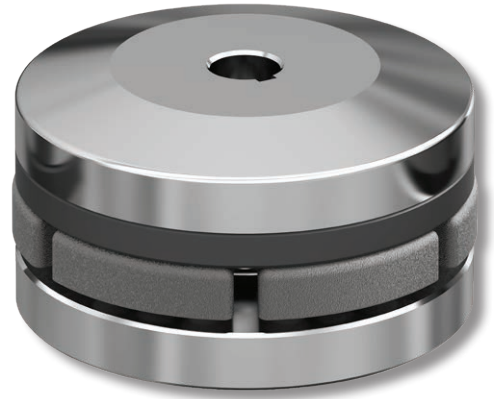

Bearing Model	TB160S6
Capacity	27000 Lbs (120.1 kN)
Application (Standard)	10SME 75 HP to 270 HP
No. of Segments	6 Nrs
Segment Area	1807 mm ² (2.801 in ²)
Total Contact Area	10842 mm ² (16.805 in ²)
Carbon Pad OD	160 mm (6.299 in)
Carbon Pad ID	58 mm (2.283 in)
Bearing Height	84 mm (3.307 in)

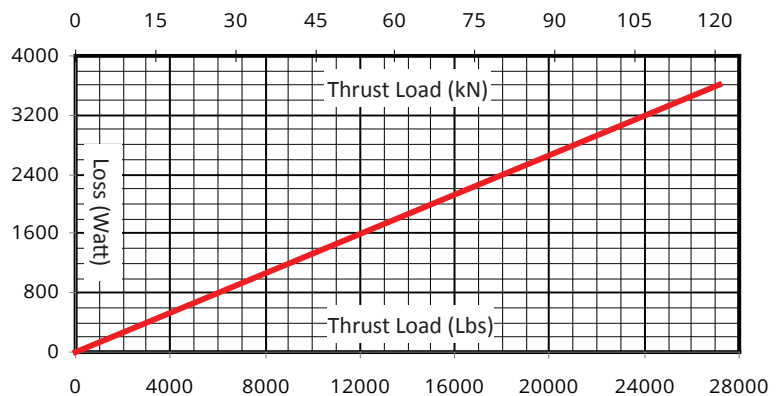
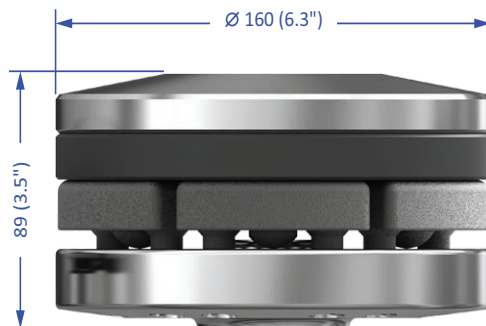
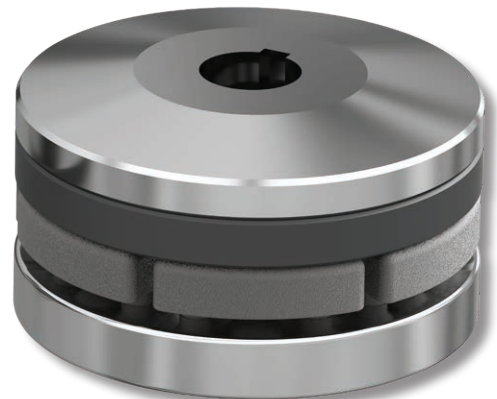

✓ Sensor Features

PT100s (Platinum Resistance Transducers) or RTDs (Resistance Temperature Detectors) are an economical and accurate method of measuring temperature, because the resistance of the PT100 chip changes in direct proportion to the temperature.

SME standard PT100s are available in 3 wire configurations. The accuracy of the measured temperature increases with the number of wires, i.e. 3 wire units give a more accurate reading than 2 wire units. When PT100s are used with a suitable measuring instrument they will display the actual temperature of the sensor, wherever it is located, with a small accuracy tolerance.

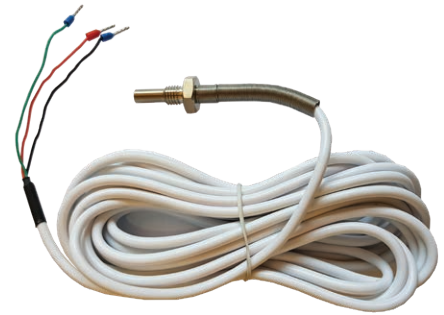

PT100 for Internal Fixing



Temperature Range: PT100 -58 °F to +392 °F

Accuracy Class: Class B

Nominal Resistance: 100 Ohms at 32 °F (The resistance will change by 0.3851 ohms of each 33.8 °F change in temperature, and the tolerance of a Class B Device is +/- 0.0012 ohms)

Standard Sheath Material: Ceramic with SS304 Cover Tube

Wire Temperature Rating: 482 °F

Recommended Operating Current: 1 m.Amp.

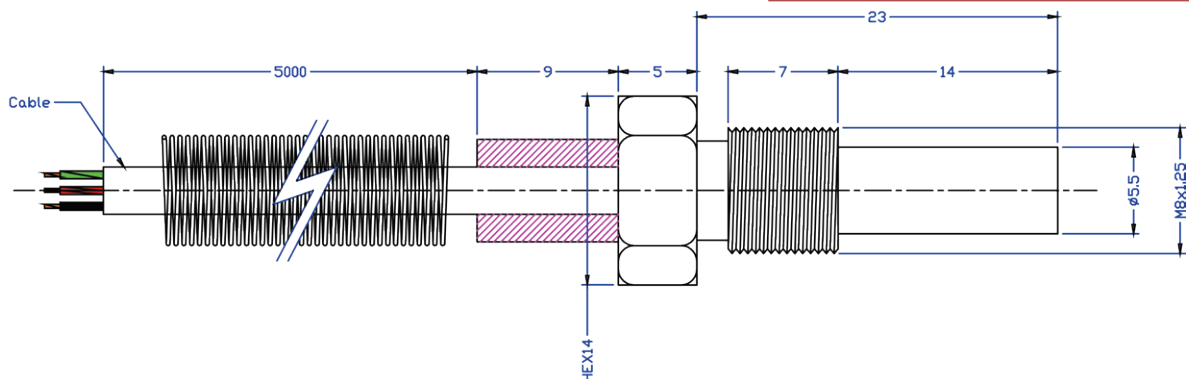

✓ Cable for Sensor

Usage: Multiwire cable specially developed for borehole submersible motor's temperature sensors.

Packing: 328 or 1640 feet coil.

Insulation: PE

Sheath: Standard Grey High Temp PVC (Other materials and colors are available upon request)

Screen: Overall Aluminum/Polyester Laminate.

Multiwire Cable for Sensor



Nearest AWG	No. of Cores	Conductors Nos./Dia (mm)	Insulation Thickness (mm)	Nominal Wire to Wire Capacitance (pf/m)	Nominal Dia (mm)
24	3	7/0.20 TC	0.30	80	4.7
24	6	7/0.20 TC	0.30	80	5.5
24	12	7/0.20 TC	0.30	80	7.5

208 Volt @ 60 Hz

@ Temp. 140 °F (60 °C)

Motor Size		AWG Wire Size, Copper Wire, Three Wire Cables (Length in Feet)															
HP	KW	14	12	10	8	6	4	3	2	1	0	00	000	0000	250	300	
5.5	4.0	110	170	270	430	680	1080	1355	1710	2160							
7.5	5.5		130	205	325	515	820	1030	1300	1640	2070						
10	7.5			160	250	400	635	795	1000	1265	1595	2000					
15	11				170	270	425	535	675	850	1070	1345	1700	2140	2540	3040	
20	15					210	335	420	530	670	845	1060	1340	1685	2000	2390	
25	18.5						270	340	430	540	680	855	1080	1360	1615	1930	
30	22						230	285	360	455	575	720	910	1145	1360	1625	
40	30							215	275	345	435	545	685	865	1025	1225	
50	37								175	220	280	350	440	555	700	830	995
60	45									185	235	295	370	465	590	695	835

208 Volt @ 60 Hz

@ Temp. 167 °F (75 °C)

Motor Size		AWG Wire Size, Copper Wire, Three Wire Cables (Length in Feet)															
HP	KW	14	12	10	8	6	4	3	2	1	0	00	000	0000	250	300	
5.5	4.0	105	160	260	410	645	1030	1290	1630	2055							
7.5	5.5		125	195	310	490	780	980	1235	1560	1970						
10	7.5			155	240	380	605	755	955	1205	1515	1905					
15	11				160	255	405	510	640	810	1020	1280	1620	2035	2415	2890	
20	15					200	320	400	505	635	800	1005	1275	1600	1900	2275	
25	18.5						260	325	410	515	650	815	1030	1295	1535	1840	
30	22						220	275	345	435	545	685	865	1090	1290	1545	
40	30							205	260	325	410	515	655	820	975	1165	
50	37								170	210	265	335	420	530	665	790	945
60	45									175	225	280	350	445	560	665	795

Cable length calculations are based on voltage drop of 5.5% and above mentioned working temperature.

230 Volt @ 60 Hz

@ Temp. 140 °F (60 °C)

Motor Size		AWG Wire Size, Copper Wire, Three Wire Cables (Length in Feet)															
HP	KW	14	12	10	8	6	4	3	2	1	0	00	000	0000	250	300	
5.5	4.0	130	200	320	505	800	1270	1595	2015	2540							
7.5	5.5		150	245	385	605	965	1210	1530	1930	2435						
10	7.5			185	290	460	735	920	1160	1465	1850	2320					
15	11				200	320	505	635	800	1005	1270	1595	2015	2540	3010	3605	
20	15					250	395	495	625	790	995	1245	1575	1985	2355	2820	
25	18.5						320	405	510	640	810	1015	1280	1615	1915	2290	
30	22						270	340	430	540	685	855	1085	1365	1615	1935	
40	30							255	320	405	510	640	805	1015	1205	1440	
50	37								210	265	335	420	530	665	840	995	1190
60	45									225	280	355	445	560	705	835	1000

230 Volt @ 60 Hz

@ Temp. 167 °F (75 °C)

Motor Size		AWG Wire Size, Copper Wire, Three Wire Cables (Length in Feet)															
HP	KW	14	12	10	8	6	4	3	2	1	0	00	000	0000	250	300	
5.5	4.0	120	190	305	480	760	1210	1520	1915	2420							
7.5	5.5		145	230	365	575	920	1150	1455	1835	2315						
10	7.5			175	280	440	700	875	1105	1395	1760	2210					
15	11				190	300	480	600	760	960	1210	1520	1920	2415	2865	3430	
20	15					235	375	470	595	750	945	1185	1500	1890	2240	2680	
25	18.5						305	385	485	610	770	965	1220	1535	1820	2180	
30	22						260	325	410	515	650	815	1030	1295	1540	1840	
40	30							240	305	385	485	605	765	965	1145	1370	
50	37								200	255	320	400	505	635	800	950	1135
60	45									210	265	335	420	535	670	795	950

Cable length calculations are based on voltage drop of 5.5% and above mentioned working temperature.

380 Volt @ 60 Hz		@ Temp. 140 °F (60 °C)															
Motor Size		AWG Wire Size, Copper Wire, Three Wire Cables (Length in Feet)															
HP	KW	14	12	10	8	6	4	3	2	1	0	00	000	0000	250	300	
5.5	4.0	355	555	890	1405	2225	3545	4450	5620								
7.5	5.5	265	415	665	1055	1665	2655	3330	4205	5305							
10	7.5	205	325	520	820	1300	2070	2595	3280	4135	5220						
15	11			355	565	890	1420	1780	2245	2835	3575	4490	5675				
20	15				435	690	1095	1375	1735	2185	2760	3465	4385	5515			
25	18.5				360	565	900	1130	1425	1795	2265	2845	3600	4530	5375		
30	22					470	750	940	1185	1495	1885	2370	2995	3770	4475	5355	
40	30						565	710	895	1130	1425	1790	2265	2850	3380	4045	
50	37							560	705	890	1120	1405	1780	2240	2655	3180	
60	45								570	720	910	1140	1445	1815	2155	2580	
70	52									625	785	990	1250	1570	1865	2230	
75	55										585	740	930	1175	1475	1750	2095

380 Volt @ 60 Hz		@ Temp. 167 °F (75 °C)															
Motor Size		AWG Wire Size, Copper Wire, Three Wire Cables (Length in Feet)															
HP	KW	14	12	10	8	6	4	3	2	1	0	00	000	0000	250	300	
5.5	4.0	335	525	845	1340	2120	3375	4235	5345								
7.5	5.5	250	395	635	1000	1585	2525	3170	4000	5050							
10	7.5	195	310	495	780	1235	1970	2470	3120	3935	4965						
15	11			340	535	845	1350	1690	2135	2695	3400	4270	5400				
20	15				415	655	1040	1305	1650	2080	2625	3300	4170	5250			
25	18.5				340	540	855	1075	1355	1710	2155	2710	3425	4310	5115		
30	22					450	715	895	1130	1425	1795	2255	2850	3585	4255	5095	
40	30						540	675	855	1075	1355	1705	2155	2710	3215	3850	
50	37							530	670	845	1065	1340	1690	2130	2525	3025	
60	45								545	685	865	1085	1375	1730	2050	2455	
70	52									595	750	940	1190	1495	1775	2125	
75	55										560	705	885	1115	1405	1665	1995

Cable length calculations are based on voltage drop of 5.5% and above mentioned working temperature.

380 Volt @ 50 Hz

@ Temp. 140 °F (60 °C)

Motor Size		AWG Wire Size, Copper Wire, Three Wire Cables (Length in Feet)																
HP	KW	14	12	10	8	6	4	3	2	1	0	00	000	0000	250	300		
5.5	4.0	400	630	1005	1595	2520	4020	5040	6370									
7.5	5.5	300	470	755	1195	1890	3015	3780	4775	6025								
10	7.5	240	375	600	945	1495	2385	2990	3780	4765	6015							
15	11		255	405	645	1015	1620	2030	2565	3235	4080	5125	6480					
20	15			315	495	785	1245	1565	1975	2490	3140	3945	4990	6280				
25	18.5			260	410	645	1025	1285	1625	2050	2585	3245	4105	5170	6135			
30	22				335	535	850	1065	1340	1695	2135	2680	3390	4270	5065	6060		
40	30					410	650	815	1030	1295	1635	2055	2595	3265	3875	4640		
50	37						510	640	810	1020	1285	1615	2040	2570	3050	3650		
60	45							415	520	660	830	1045	1315	1660	2090	2480	2965	
70	52								450	570	715	905	1135	1435	1805	2145	2565	
75	55									425	535	675	850	1065	1350	1695	2015	2410
		1	0	00	000	0000	250	300	350	400	450	500	600	750	800	1000		
40	30	1295	1635	2055	2595	3265	3875	4640	5400	6195								
50	37	1020	1285	1615	2040	2570	3050	3650	4250	4875	5475	6075						
60	45	830	1045	1315	1660	2090	2480	2965	3455	3960	4450	4935	5930					
70	52	715	905	1135	1435	1805	2145	2565	2985	3425	3845	4265	5125	6410				
75	55	675	850	1065	1350	1695	2015	2410	2805	3220	3615	4010	4820	6020				
100	75	545	685	865	1090	1370	1630	1950	2270	2600	2920	3240	3895	4865	5185	6490		
125	93			700	885	1115	1325	1585	1845	2115	2375	2635	3165	3955	4215	5275		
150	112				745	935	1110	1325	1545	1770	1990	2205	2650	3315	3530	4420		
175	130					800	950	1135	1325	1515	1705	1890	2270	2840	3025	3785		
200	150						710	840	1005	1170	1340	1505	1670	2010	2510	2675	3350	
250	186							660	790	920	1055	1180	1310	1575	1970	2100	2625	
270	186								735	855	985	1105	1225	1470	1835	1960	2450	

Cable length calculations are based on voltage drop of 5.5% and above mentioned working temperature.

Cable Sizing

380 Volt @ 50 Hz		@ Temp. 167 °F (75 °C)																
Motor Size		AWG Wire Size, Copper Wire, Three Wire Cables (Length in Feet)																
HP	KW	14	12	10	8	6	4	3	2	1	0	00	000	0000	250	300		
5.5	4.0	380	595	960	1515	2400	3825	4795	6060									
7.5	5.5	285	450	720	1140	1800	2870	3600	4545	5735								
10	7.5	225	355	570	900	1425	2270	2845	3595	4535	5725							
15	11		240	385	610	965	1540	1930	2440	3075	3880	4875	6165					
20	15			300	470	745	1185	1490	1880	2370	2990	3755	4750	5975				
25	18.5			245	390	615	975	1225	1545	1950	2460	3090	3905	4920	5835			
30	22				320	505	805	1010	1275	1610	2030	2550	3225	4060	4820	5770		
40	30					390	620	775	980	1235	1555	1955	2470	3110	3690	4415		
50	37						485	610	770	970	1225	1535	1945	2445	2900	3475		
60	45							395	495	625	790	995	1250	1580	1990	2360	2825	
70	52								430	540	685	860	1080	1365	1720	2040	2440	
75	55									405	510	640	810	1015	1285	1615	1915	2295
		1	0	00	000	0000	250	300	350	400	450	500	600	750	800	1000		
40	30	1235	1555	1955	2470	3110	3690	4415	5140	5895								
50	37	970	1225	1535	1945	2445	2900	3475	4045	4635	5210	5780						
60	45	790	995	1250	1580	1990	2360	2825	3285	3770	4235	4695	5645					
70	52	685	860	1080	1365	1720	2040	2440	2840	3260	3660	4060	4880	6100				
75	55	640	810	1015	1285	1615	1915	2295	2670	3060	3440	3815	4585	5730				
100	75	520	655	820	1040	1305	1550	1855	2160	2475	2780	3085	3705	4630	4935	6175		
125	93			670	845	1060	1260	1505	1755	2010	2260	2505	3010	3765	4010	5020		
150	112				705	890	1055	1265	1470	1685	1895	2100	2525	3155	3360	4205		
175	130					760	905	1080	1260	1445	1620	1800	2160	2700	2880	3600		
200	150						675	800	955	1115	1275	1435	1590	1910	2390	2545	3185	
250	186							630	750	875	1000	1125	1250	1500	1875	1995	2500	
270	186								700	815	935	1050	1165	1400	1750	1865	2330	

Cable length calculations are based on voltage drop of 5.5% and above mentioned working temperature.

460 Volt @ 60 Hz

@ Temp. 140 °F (60 °C)

Motor Size		AWG Wire Size, Copper Wire, Three Wire Cables (Length in Feet)																
HP	KW	14	12	10	8	6	4	3	2	1	0	00	000	0000	250	300		
5.5	4.0	515	805	1290	2045	3235	5160	6470	8175									
7.5	5.5	385	600	960	1525	2410	3840	4820	6085	7680								
10	7.5	300	465	750	1185	1875	2990	3750	4735	5975	7535							
15	11		320	515	815	1290	2055	2575	3250	4105	5175	6500	8220					
20	15			400	630	995	1590	1990	2515	3175	4005	5030	6360	8005				
25	18.5			325	515	815	1300	1630	2060	2600	3280	4120	5210	6560	7785			
30	22				430	680	1085	1360	1715	2165	2730	3430	4340	5460	6480	7755		
40	30					515	820	1025	1295	1635	2065	2590	3275	4125	4895	5860		
50	37						645	810	1020	1285	1625	2040	2575	3245	3850	4605		
60	45							535	675	850	1070	1350	1695	2145	2700	3205	3835	
70	52								585	735	930	1170	1470	1860	2340	2775	3320	
75	55									550	695	880	1110	1390	1760	2215	2630	3145
		1	0	00	000	0000	250	300	350	400	450	500	600	750	800	1000		
40	30	1635	2065	2590	3275	4125	4895	5860	6820	7825								
50	37	1285	1625	2040	2575	3245	3850	4605	5365	6150	6910	7665						
60	45	1070	1350	1695	2145	2700	3205	3835	4465	5120	5750	6380	7665					
70	52	930	1170	1470	1860	2340	2775	3320	3865	4435	4980	5525	6640	8300				
75	55	880	1110	1390	1760	2215	2630	3145	3660	4200	4715	5235	6285	7860				
100	75	710	895	1125	1425	1790	2125	2545	2960	3395	3815	4235	5085	6355	6775	8480		
125	93			905	1145	1440	1710	2045	2380	2730	3065	3400	4085	5110	5445	6815		
150	112				960	1210	1435	1715	1995	2290	2570	2855	3430	4285	4565	5715		
175	130					1020	1210	1450	1685	1935	2170	2410	2895	3620	3855	4830		
200	150						885	1045	1255	1460	1670	1880	2085	2505	3130	3335	4175	
250	186							825	990	1150	1320	1485	1645	1975	2470	2635	3295	
270	186								925	1080	1235	1390	1540	1850	2315	2465	3085	

Cable length calculations are based on voltage drop of 5.5% and above mentioned working temperature.

460 Volt @ 60 Hz		@ Temp. 167 °F (75 °C)															
Motor Size		AWG Wire Size, Copper Wire, Three Wire Cables (Length in Feet)															
HP	KW	14	12	10	8	6	4	3	2	1	0	00	000	0000	250	300	
5.5	4.0	490	765	1230	1945	3080	4910	6160	7780								
7.5	5.5	365	570	915	1450	2295	3655	4585	5790	7305							
10	7.5	285	445	715	1130	1785	2845	3565	4505	5685	7170						
15	11		305	490	775	1225	1955	2450	3095	3905	4925	6185	7825				
20	15			380	600	950	1510	1895	2395	3020	3810	4785	6050	7615			
25	18.5			310	490	780	1240	1555	1960	2475	3120	3920	4960	6240	7405		
30	22				410	650	1030	1295	1635	2060	2600	3265	4130	5195	6165	7380	
40	30					490	780	980	1235	1555	1965	2465	3120	3925	4660	5575	
50	37						615	770	970	1225	1545	1940	2450	3085	3665	4385	
60	45						510	640	810	1020	1285	1615	2040	2570	3050	3650	
70	52							555	700	885	1115	1400	1770	2225	2640	3160	
75	55								525	665	835	1055	1325	1675	2105	2500	2995
		1	0	00	000	0000	250	300	350	400	450	500	600	750	800	1000	
40	30	1555	1965	2465	3120	3925	4660	5575	6490	7445							
50	37	1225	1545	1940	2450	3085	3665	4385	5105	5855	6575	7295					
60	45	1020	1285	1615	2040	2570	3050	3650	4250	4875	5470	6070	7295				
70	52	885	1115	1400	1770	2225	2640	3160	3680	4220	4740	5260	6315	7895			
75	55	835	1055	1325	1675	2105	2500	2995	3485	3995	4490	4980	5985	7480			
100	75	675	855	1070	1355	1705	2025	2420	2820	3230	3630	4030	4840	6050	6445	8070	
125	93			860	1090	1370	1625	1945	2265	2600	2920	3235	3890	4860	5180	6485	
150	112				915	1150	1365	1630	1900	2180	2445	2715	3260	4075	4345	5440	
175	130					970	1155	1380	1605	1840	2065	2295	2755	3445	3670	4595	
200	150						840	995	1190	1390	1590	1785	1985	2380	2975	3175	3970
250	186							785	940	1095	1255	1410	1565	1880	2350	2505	3135
270	186								880	1025	1180	1320	1465	1760	2200	2345	2935

Cable length calculations are based on voltage drop of 5.5% and above mentioned working temperature.



Premium Efficiency with Wide Voltage Ranges



Specially Engineered for Compatibility with VFD



Robust 400 Series Stainless Steel Thrust Assembly and Tungsten Mechanical Seal





Optimally Designed for Endurance in Sandy Conditions







Electrically Engineered for Broad Application Tolerances





Submersible Motors, Inc.

 23507 Old Howth Road,
Hempstead, TX 77445,
United States of America
 +1 (979) 826-0369

SME USA

 950 S 67th Ave
Phoenix, AZ 85043,
United States of America
 +1 (623) 478-1883
 +1 (623) 478-1884
 +1 (623) 258-3673

 info@submersiblemotorengineering.com
 www.submersiblemotorengineering.com

